



AIRBUS





LEGO.com/sustainable-packaging

LEGO® VIP

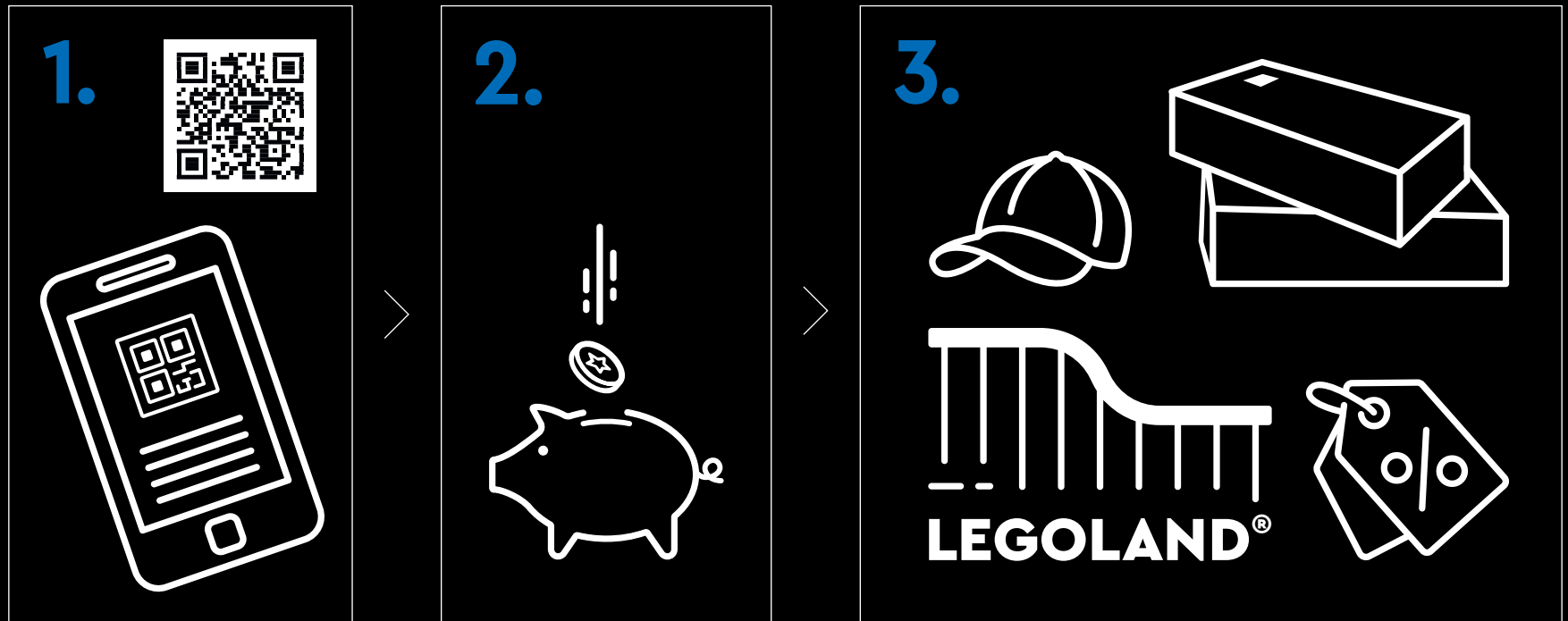

1. Sign up **2.** Earn points for purchases **3.** Redeem points for rewards, experiences, discounts & more | **1.** Melde dich an **2.** Sammle Punkte bei jedem Kauf **3.** Löse die Punkte für Belohnungen, Erlebnisse, Rabatte und Ähnliches ein | **1.** Inscrivez-vous **2.** Gagnez des points lors de vos achats **3.** Échangez vos points contre des récompenses, des expériences, des remises et bien plus encore | **1.** Iscriviti **2.** Guadagna punti con i tuoi acquisti **3.** Riscatta punti per premi, esperienze, sconti e altro ancora | **1.** Regístrate **2.** Gana puntos por tus compras **3.** Canjea puntos por recompensas, experiencias, descuentos y mucho más | **1.** Registe-se **2.** Ganhe pontos em compras **3.** Troque os pontos para prémios, experiências, descontos e muito mais | **1.** 注册 **2.** 购物赚积分 **3.** 用积分兑换奖励、体验、折扣等 | **1.** Zarejestruj się **2.** Zdobywaj punkty za zakupy **3.** Wymieniaj punkty na rabaty, przygody i inne nagrody | **1.** Zaregistrujte se **2.** Sbírejte body za nákupy **3.** Vyměňujte body za odměny, zážitky, slevy a spoustu dalšího | **1.** Zaregistrujte se **2.** Získavajte body za nákupy **3.** Uplatnite si body a získajte odmeny, rôzne zážitky, zľavy a ešte viac | **1.** Regisztrálj **2.** Szerezz pontokat minden vásárlással **3.** Váltsd be pontjaidat jutalmakra, élményekre, kedvezményekre és egyebekre | **1.** Înscric-te **2.** Câștigă puncte pentru achiziții **3.** Valorifică puncte pentru recompense, experiențe, reduceri și multe altele | **1.** Регистрируйте се **2.** Получайте точки за покупки **3.** Используйте точки за награды, услуги, отстъпки и т.н. | **1.** Reģistrējies **2.** Pelni punktus par pirkumiem **3.** Izmanto punktus, lai saņemtu balvas, izklaides iespējas, atlaides un daudz ko citu | **1.** Registreeru **2.** Teeni ostude eest punkte **3.** Lunasta punktide eest preemiad, elamused, allahindlused ja muu | **1.** Užsiregistruokite **2.** Pelnykite taškų už pirkinius **3.** Panaudokite taškus atlygiui, funkcijoms, nuolaidoms ir ne tik





欢迎搭乘
协和式飞机



列奥纳多·达·芬奇在 1487 年绘制了他的著名飞行器，但要进入 20 世纪初的动力飞行时代还需要 400 多年。从那时起，航空技术突飞猛进，每十年都会有巨大的突破。其中最耀眼的一项突破便是无与伦比的协和式飞机——世界上第一款商用超音速飞机。

第一架协和式飞机原型机于 1969 年 3 月 2 日在法国图卢兹成功完成试飞。时间就在首次载人登月的前几个月，距离路易·布莱里奥飞越英吉利海峡完成航空业一大壮举仅 60 年。商务旅客可以超音速（高达 2 马赫，两倍于音速）在靠近太空边缘的地方旅行，并且这种旅行方式有望在全球范围内普及。

极具创新的协和式飞机设计和机械功能在计算机技术实现三维设计渲染之前开发，由代表航空技术和专业知识巅峰的工程师计算、测试和完善。1976 年 1 月 21 日，首批两架商业协和式飞机同时从巴黎和伦敦起飞，标志着这个由英国和法国政府主导的合作项目的一个历史性里程碑。

2003 年 10 月 24 日，协和式飞机最后一班航班从纽约起飞，最后一次穿越大西洋，并于当年 11 月 26 日正式退役。凭借其 27 年的服役经历，协和式飞机为我们只能开始想象的航空业未来铺平了道路。

两个国家 一个愿景

随着能够将飞机飞行时间缩短一半的技术的出现，法国和英国政府通过在 20 世纪 60 年代初签署的协议实现了超音速旅行的共同愿景。飞机的设计、生产和组装由英国的英国飞机公司和法国的 Sud Aviation（空中客车的前身）共同进行。发动机的设计和开发委托给斯奈克玛和劳斯莱斯。

协和式飞机计划最终确立了欧洲航空工程的尖端产业地位。协和式飞机上许多首先引入的技术被应用到诸如 A300、A320 系列之类的商用飞机，并成为行业标准。



FP UJK

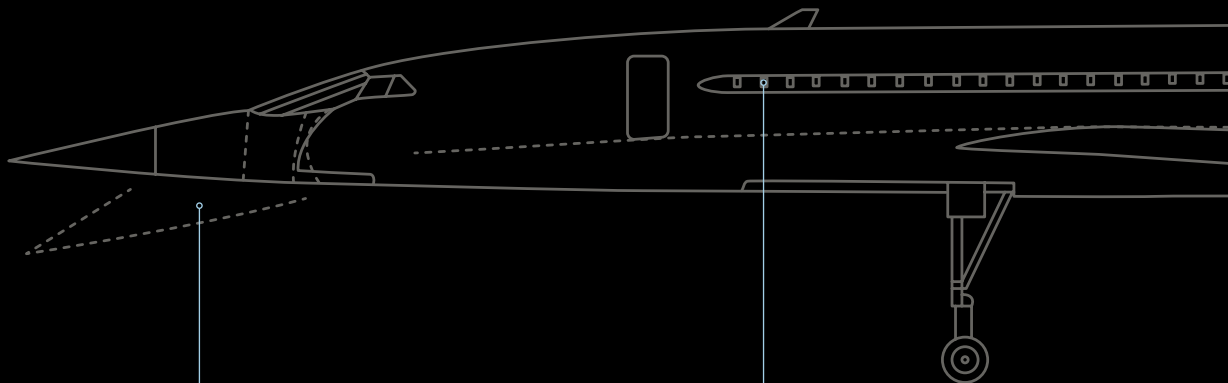

可下垂式头锥

降低机头和遮阳板可以让飞行员在着陆时看到跑道。最大下垂角度为 12.5 度。

舷窗

干燥、凉爽的冷空气在窗户玻璃之间循环，以防止飞机外部产生的极端热量进入内部。

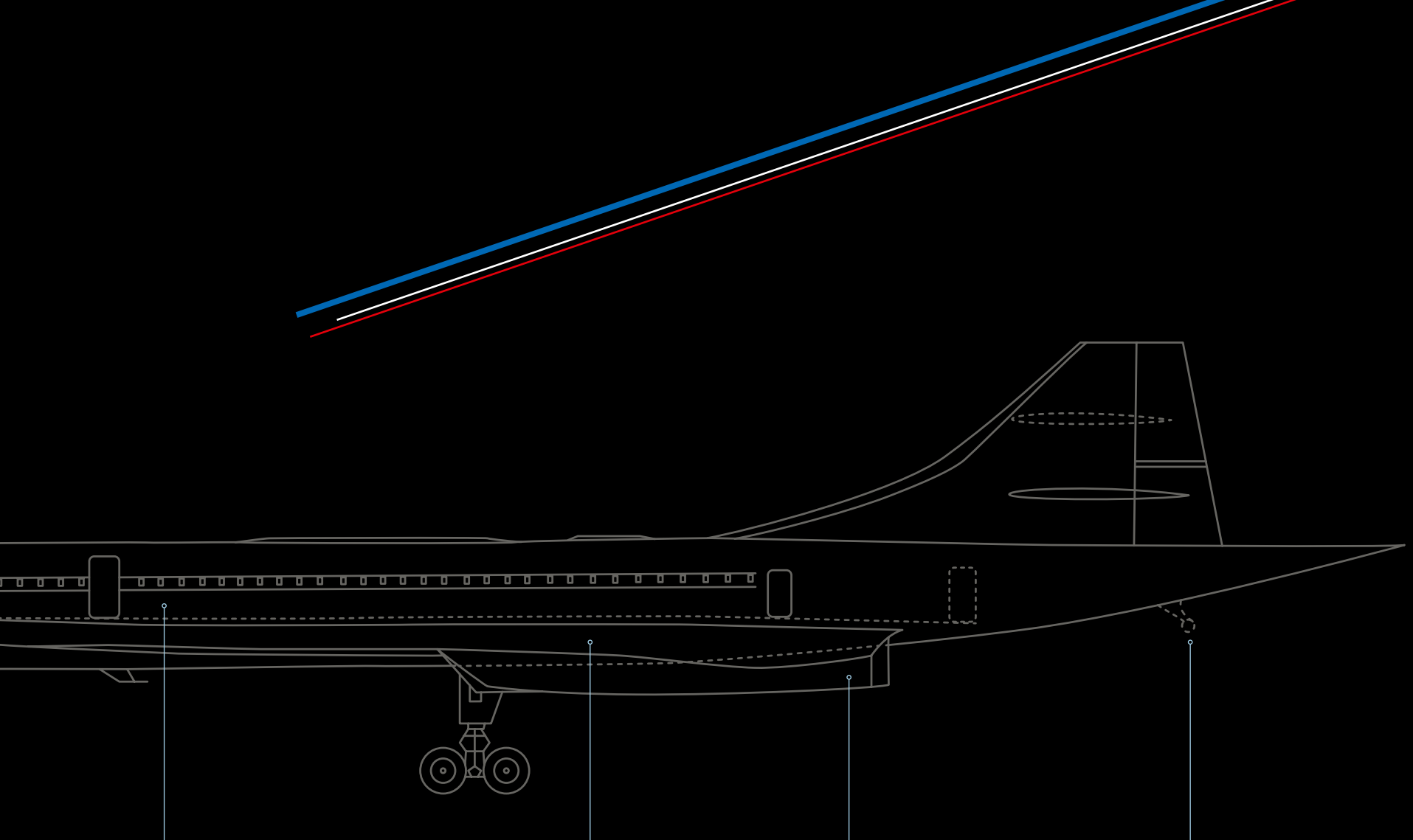

客舱

乘客坐在 40 个前舱座位和 60 个后舱座位上。

机翼

形状独特的 S 型前缘三角翼对飞机在起飞时产生升力和在飞行时减少阻力至关重要。

发动机

再加热使发动机可为起飞提供额外 20% 的功率并使飞机加速至最大速度。

尾部起落架

尾部的附加起落架用以适应飞机起飞和着陆期间的高迎角。

设计团队感言



“毫不费力地跨越音障所必需的光滑线条和流畅表面确立了协和式飞机在历史书中的地位：不仅是一款非凡的飞机，而且是无可争议的设计标志。然而，这些相同的表面却在将设计转化为乐高®积木方面提出了真正的挑战！如此独特的形状以及起落架机构和狭窄机身上的标志性可下垂式头锥迫使我们重新思考如何构建乐高飞机。但协和式飞机不仅仅是一款飞机，它展现了国家之间的非凡合作，代表了乐观向上和对未来的愿景，还向我们展示了，当我们选择共同努力时可以取得的成就。”

Milan Madge, 乐高®高级设计师

协和式飞机 (Concorde) 这个名称代表了
设计、乘客体验和国家之间合作的和谐



乐高® Icons
设计团队



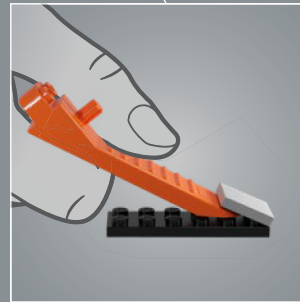
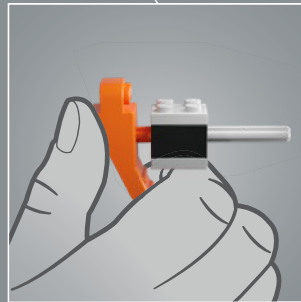
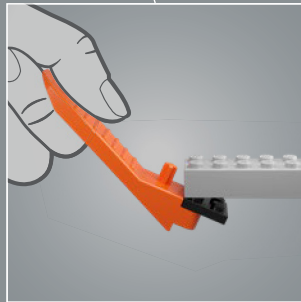
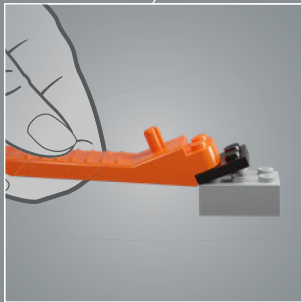
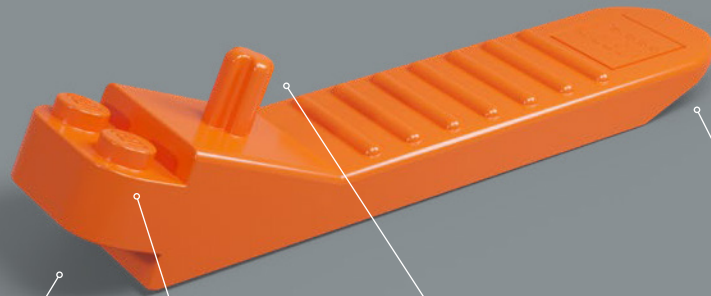

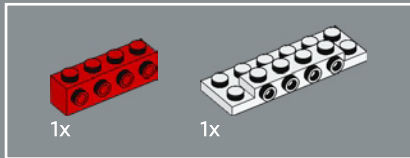

1

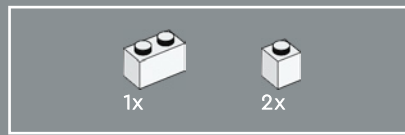
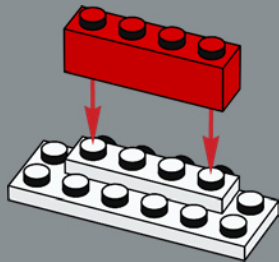

2

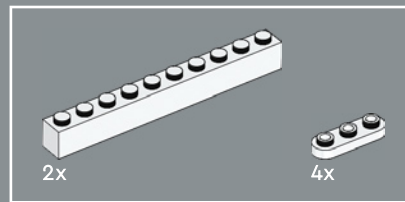
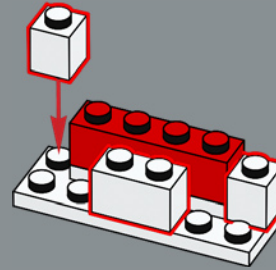

3

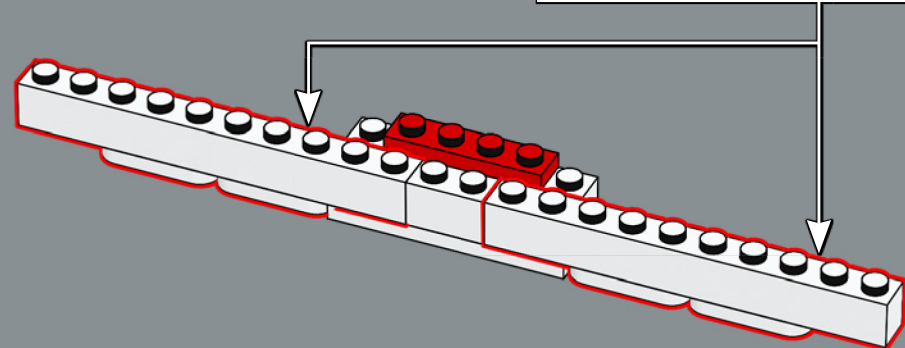
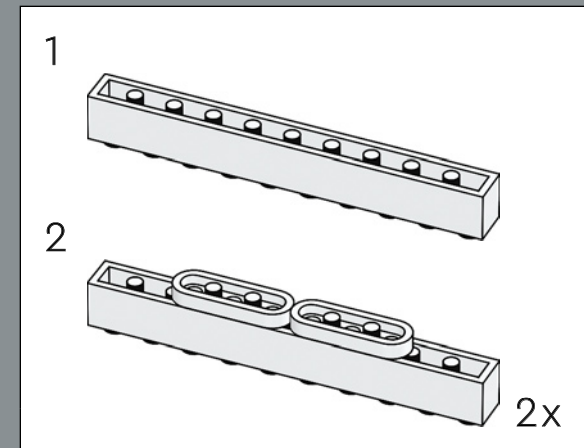

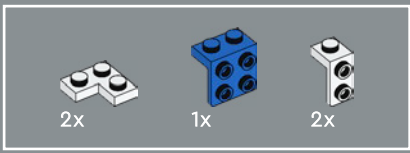

4

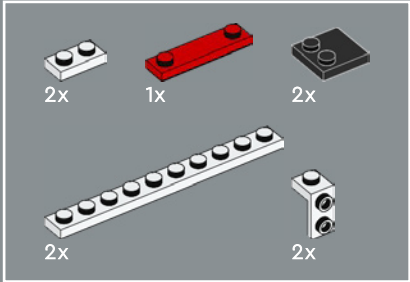
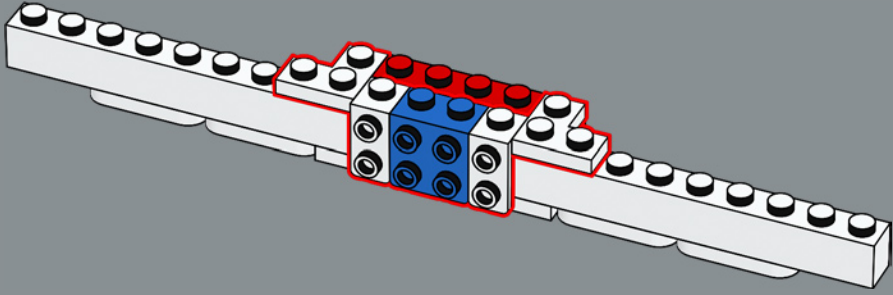

5

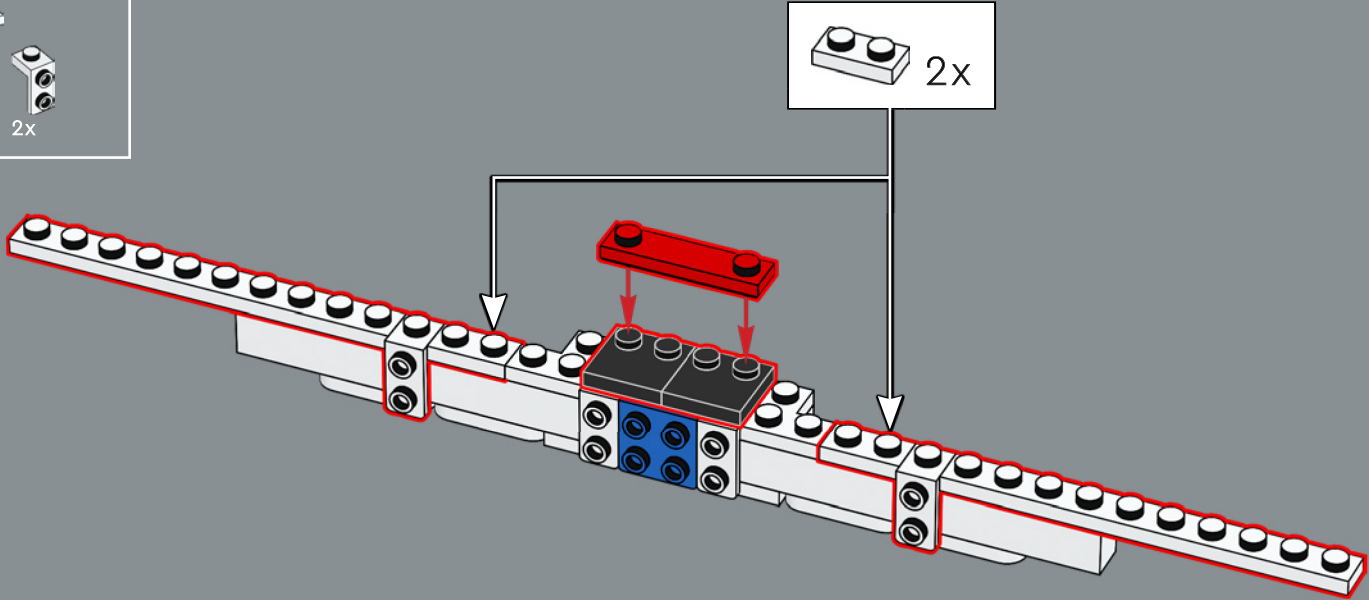

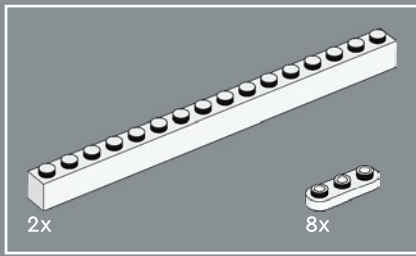

6

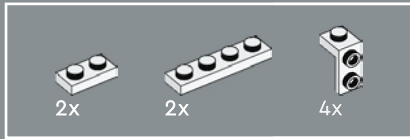
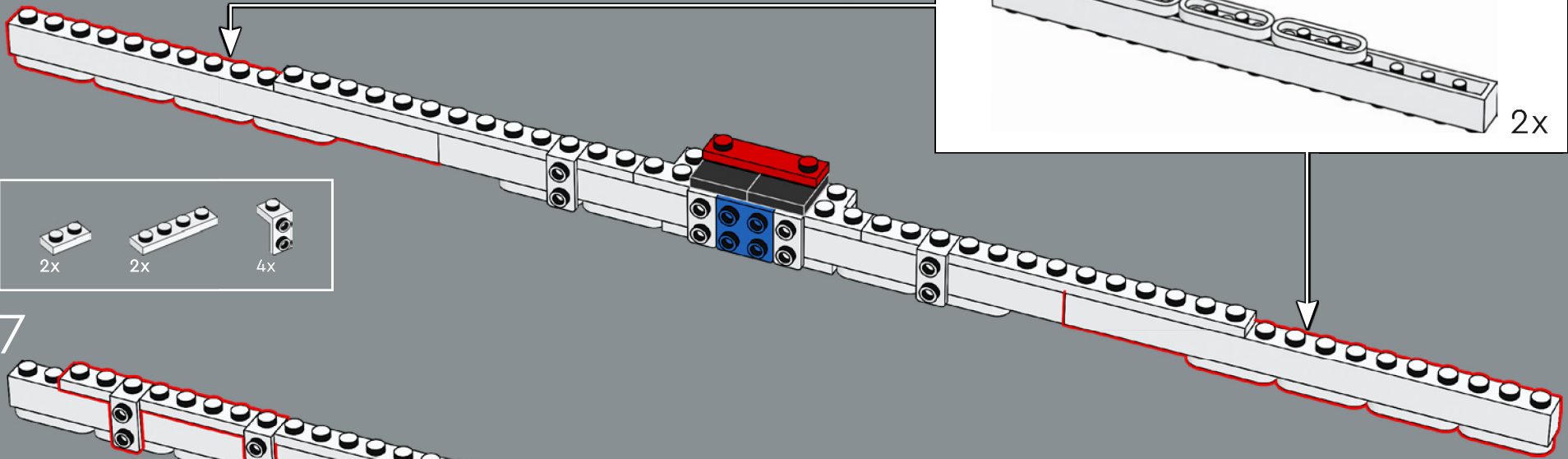

7

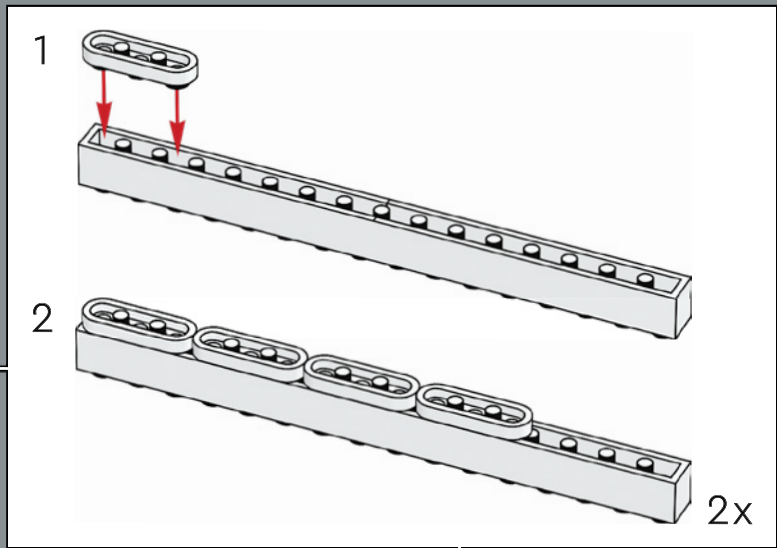
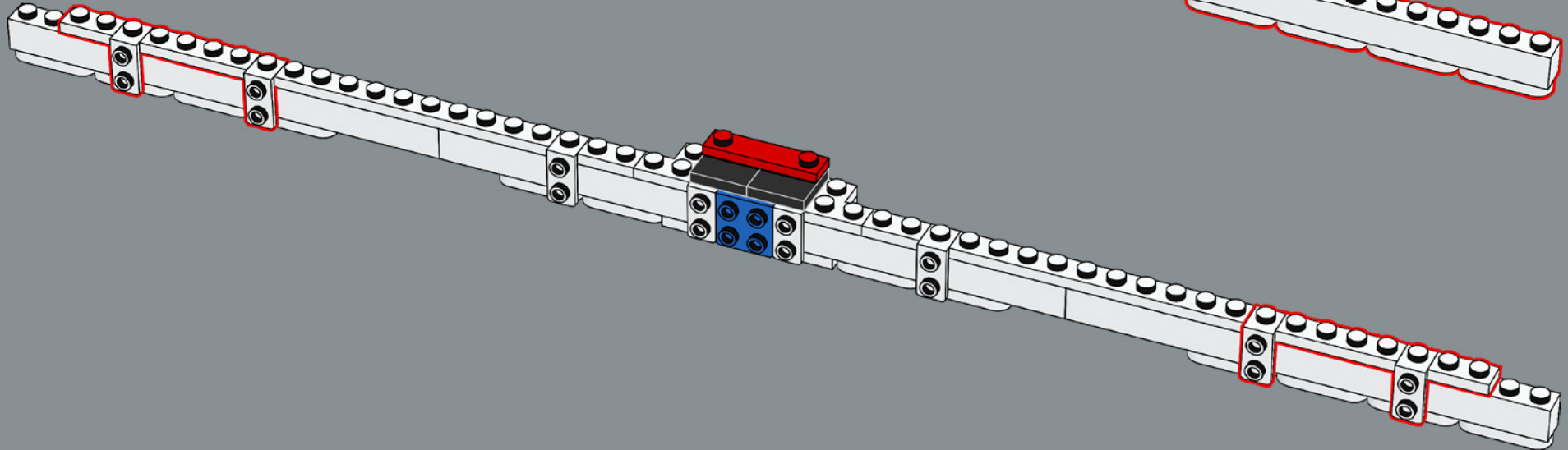



我们在哪个方向拼搭?! 从侧面拼搭乐高®协和式飞机的整个机翼能够使其更轻、更薄, 并捕获标志性的曲线三角翼。

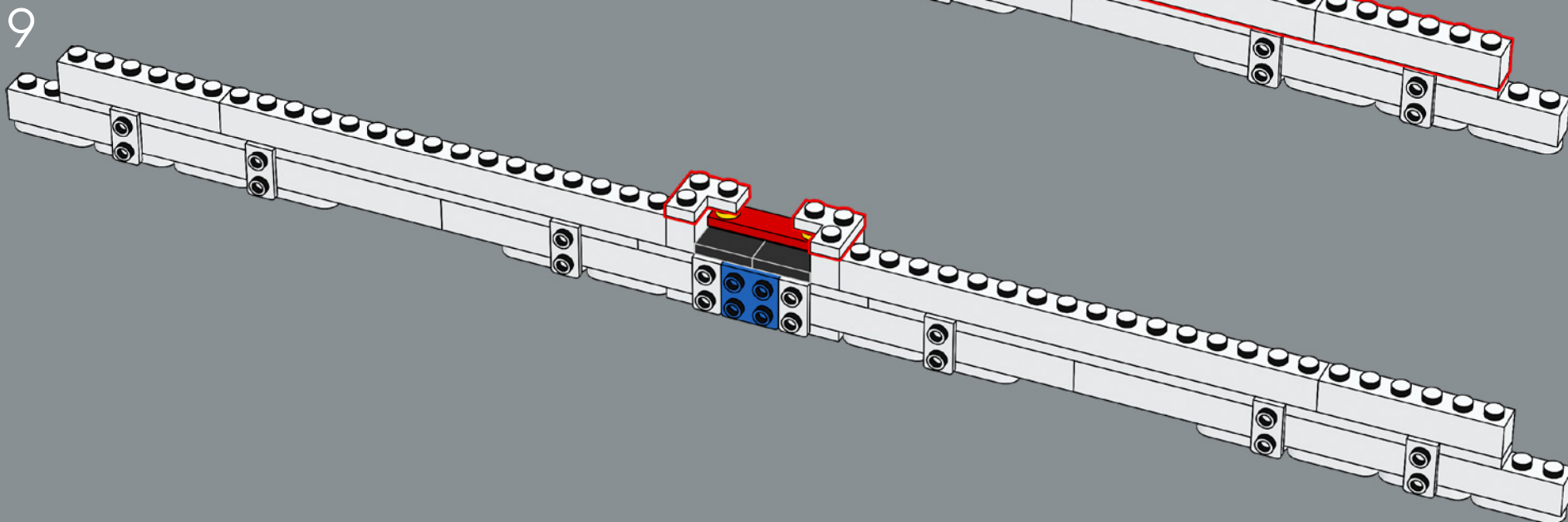
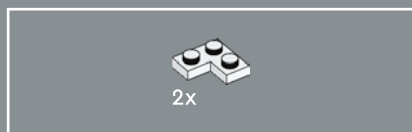
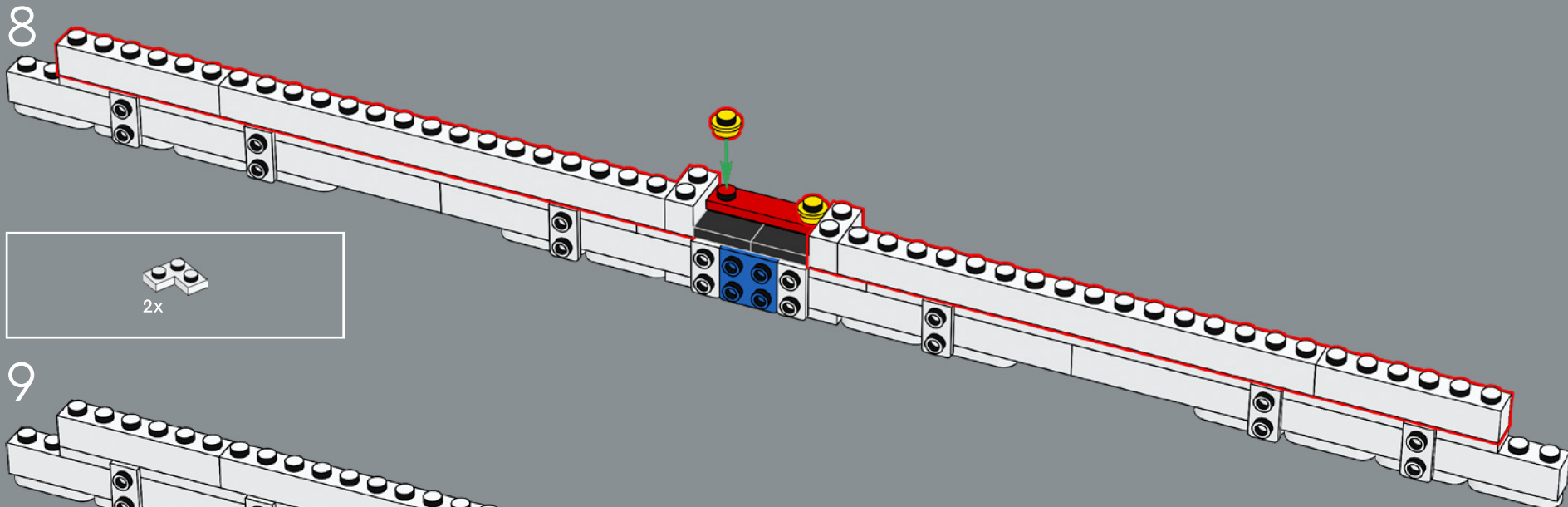
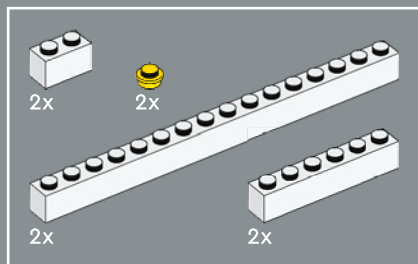

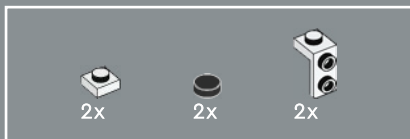

10

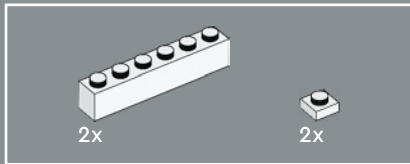
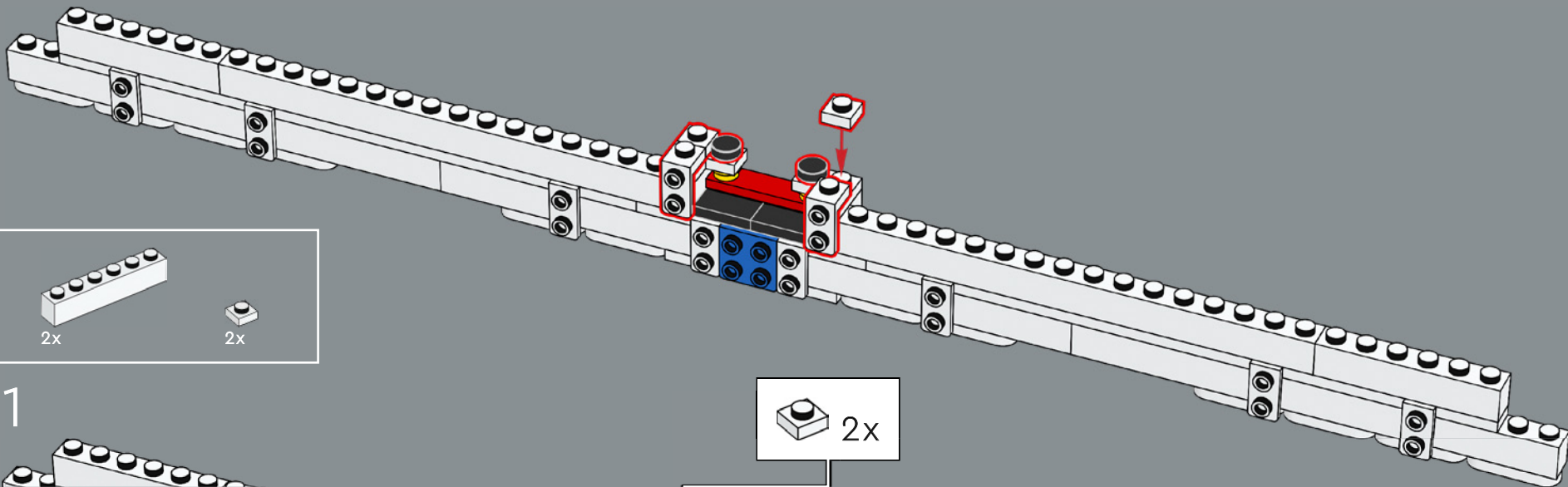

11

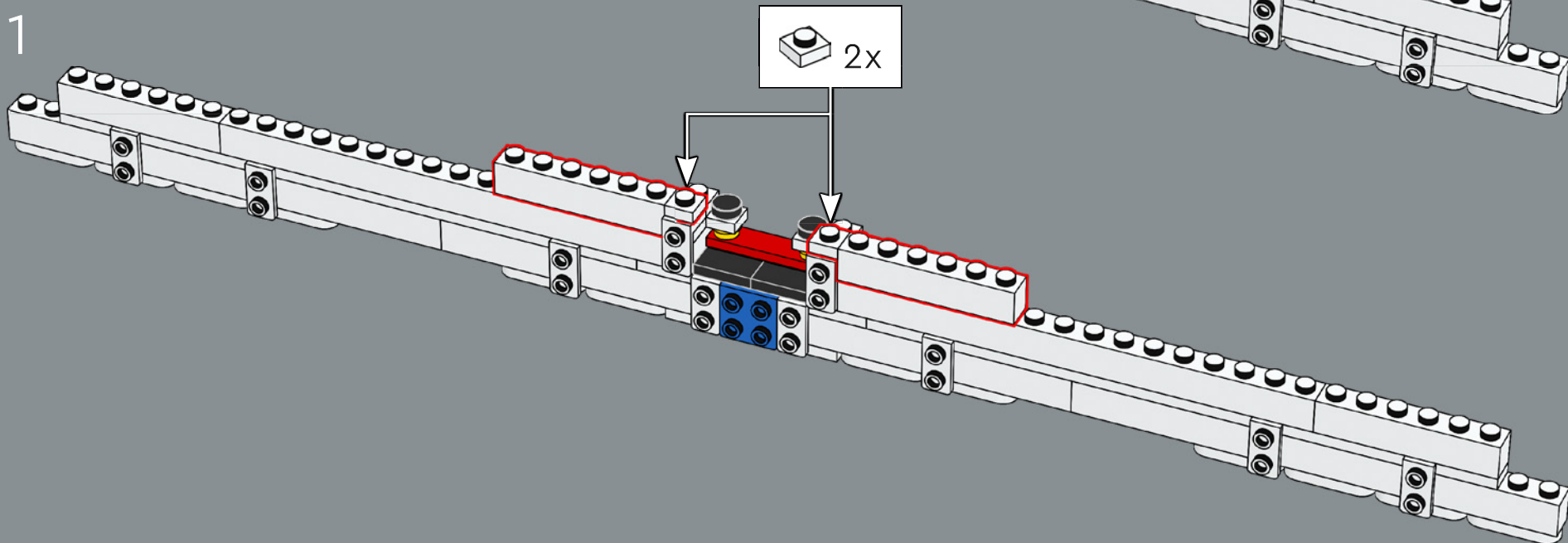

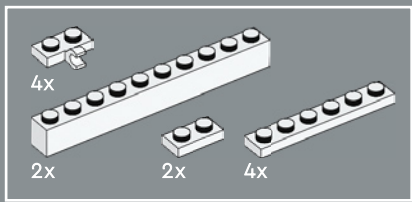

12

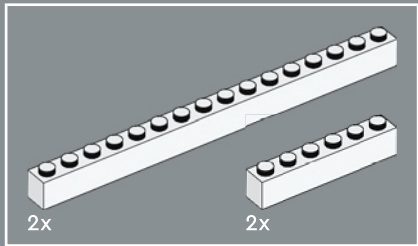
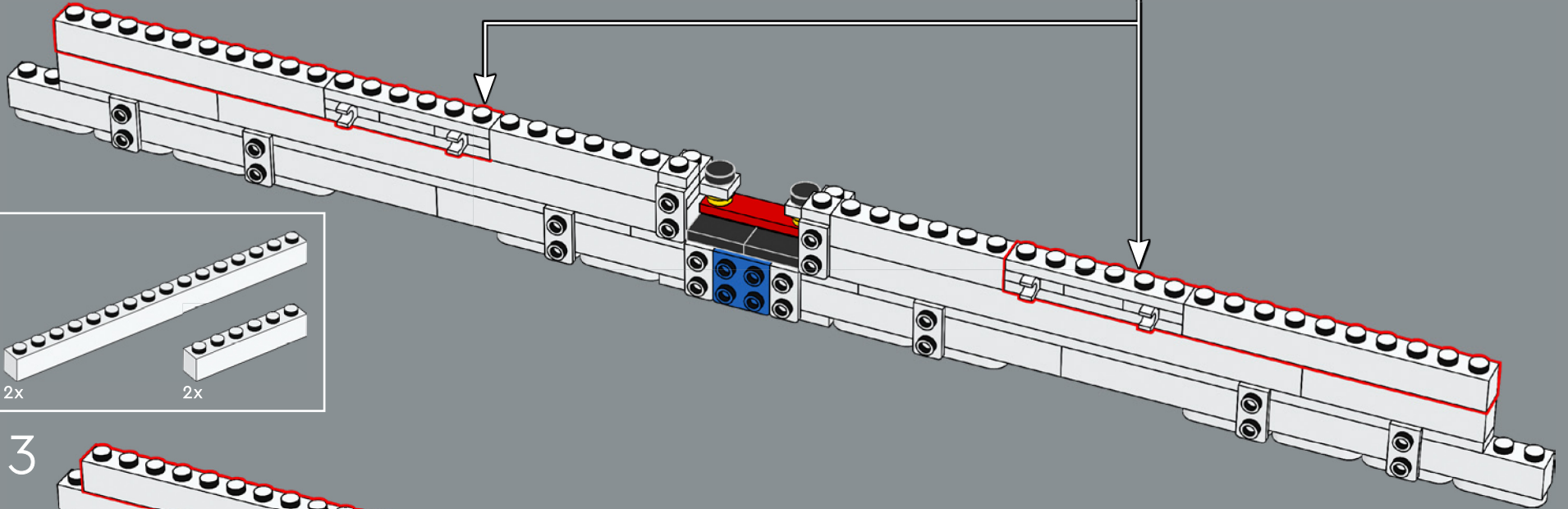
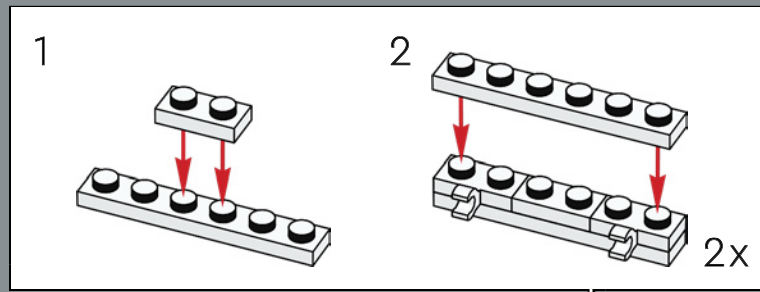

13

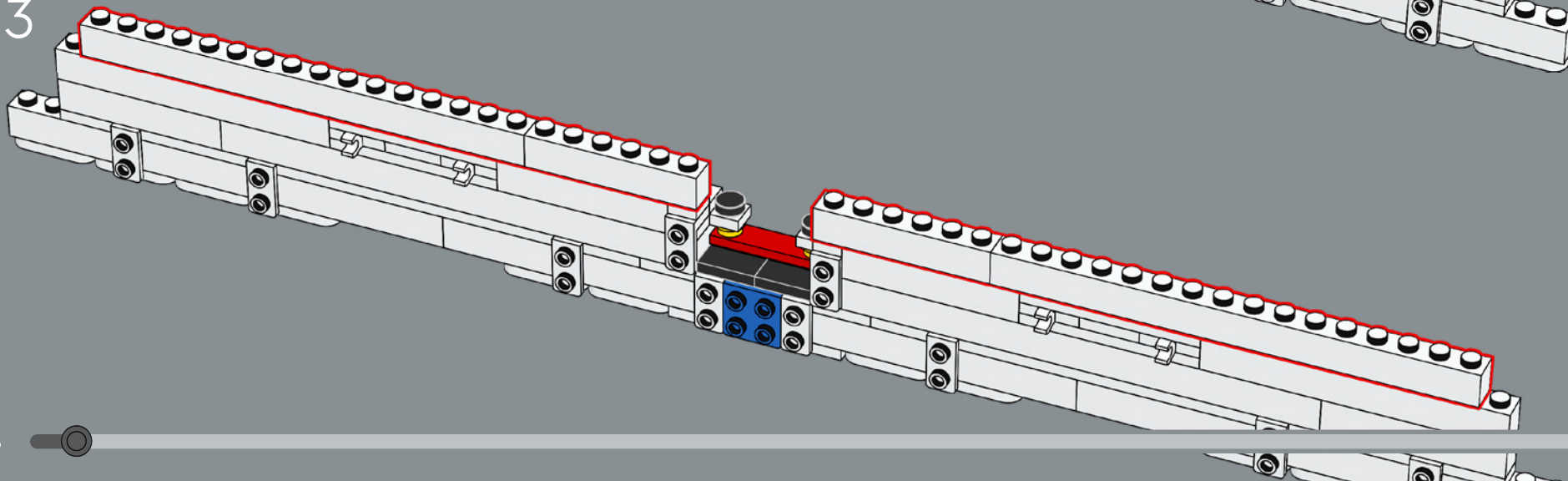

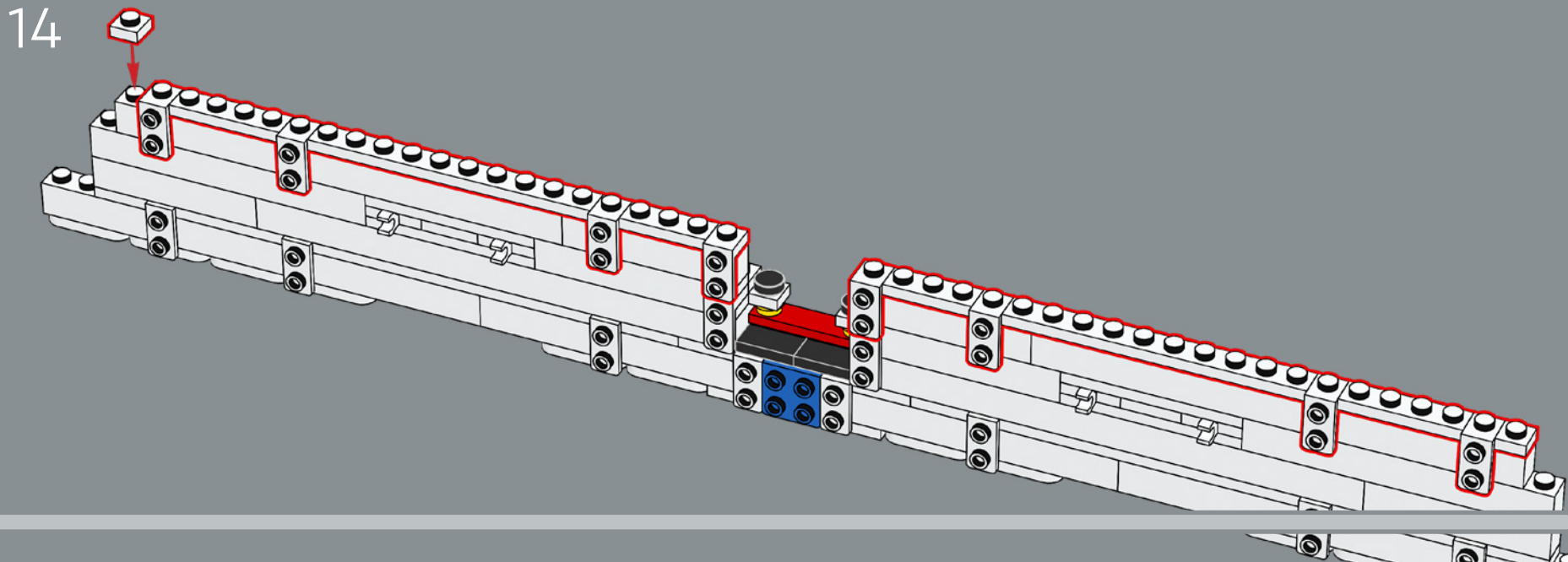
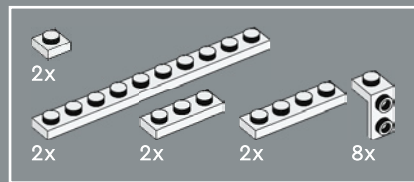



2x

15

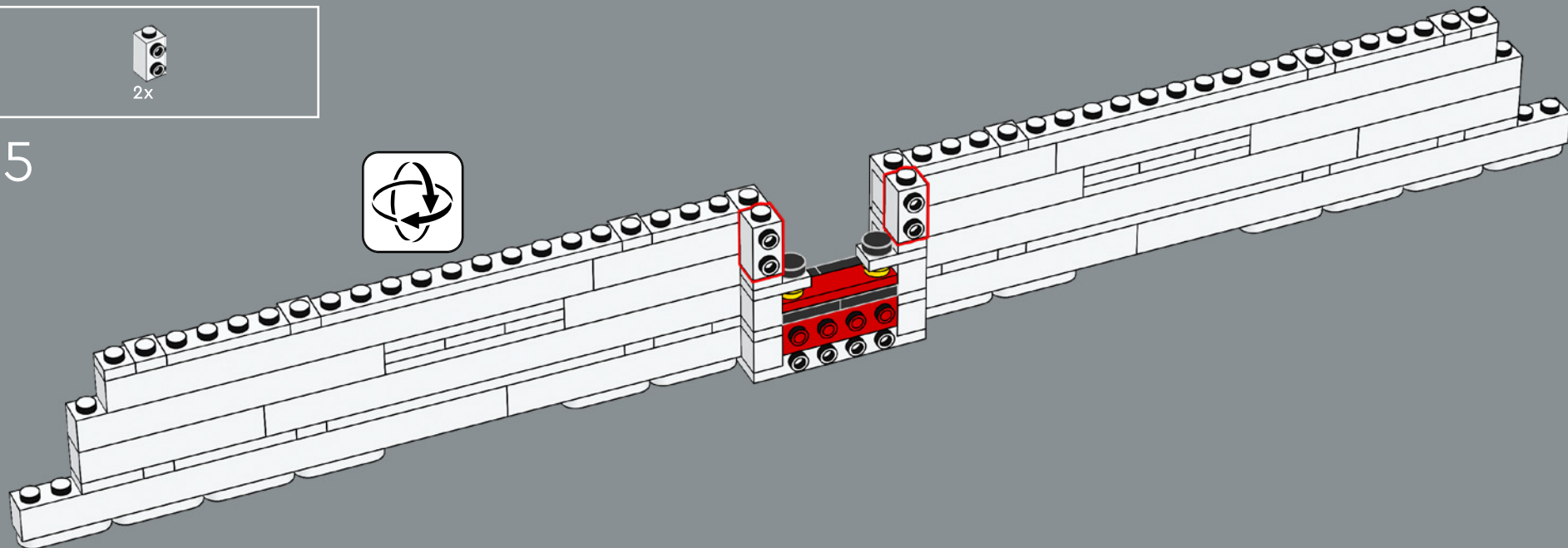

1x

1x

16

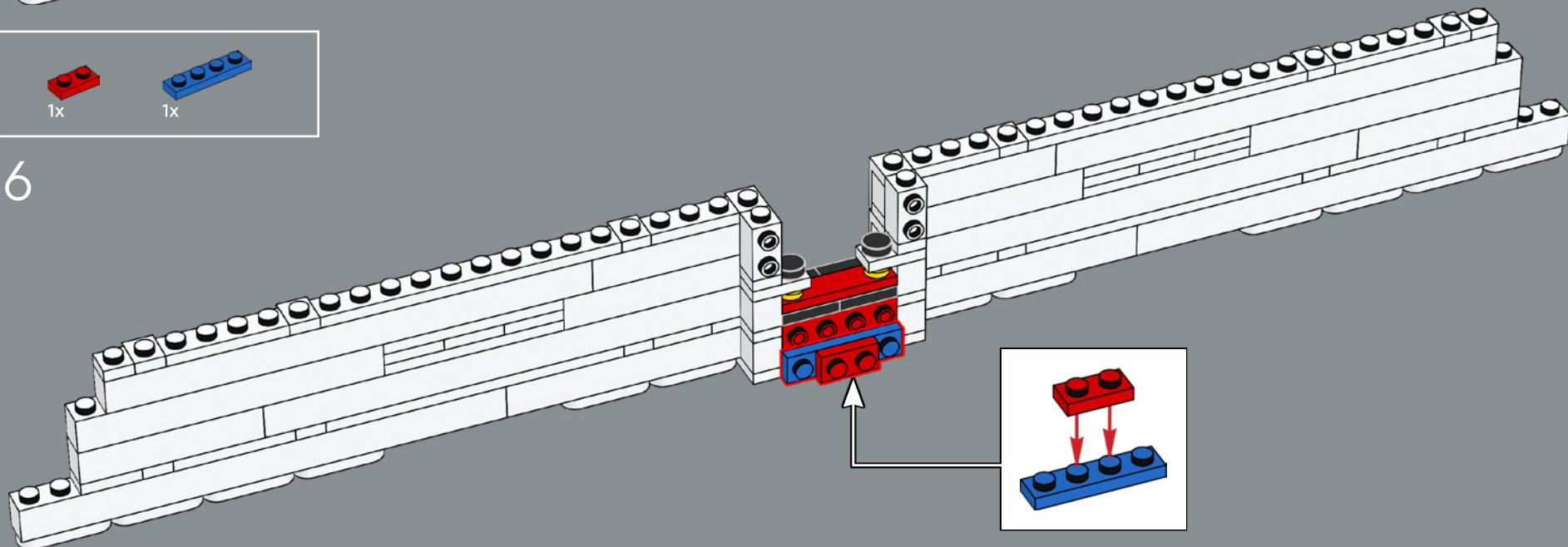

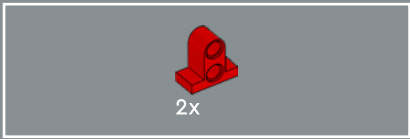

17

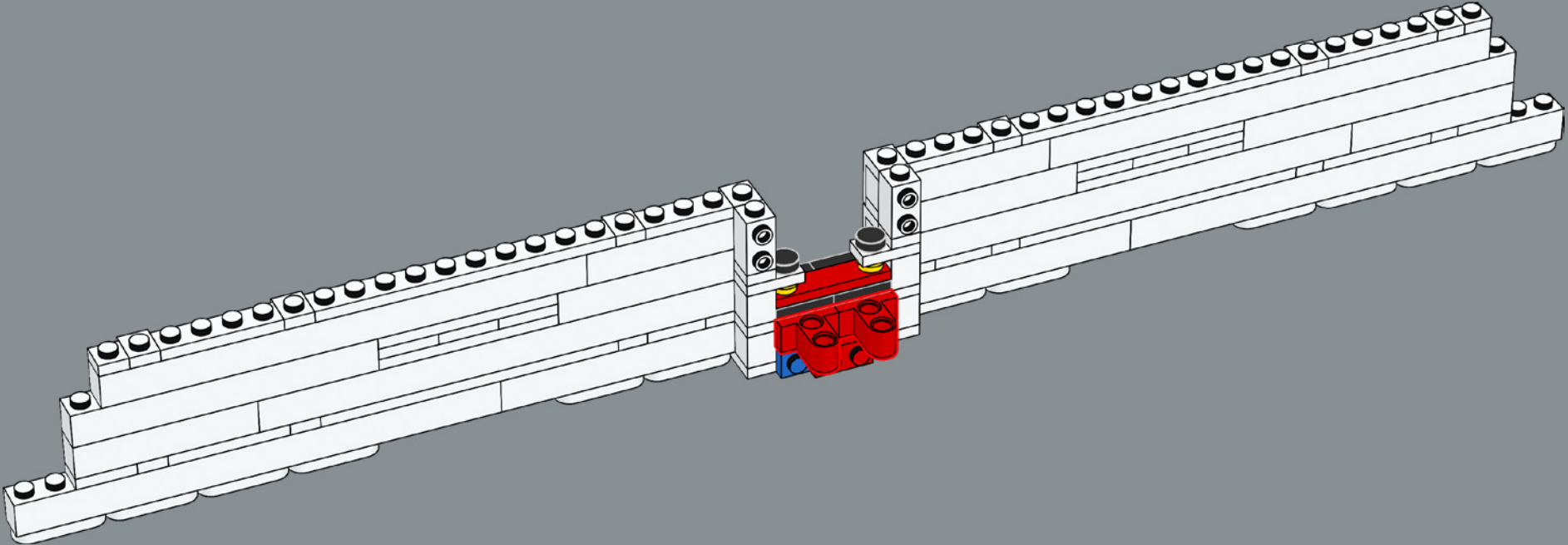

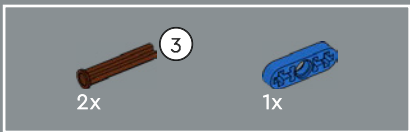
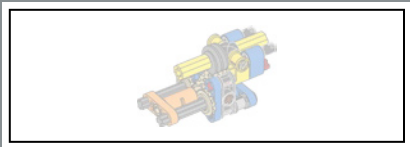

18

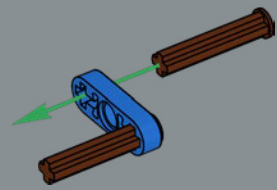

19

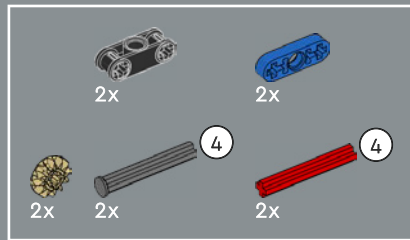
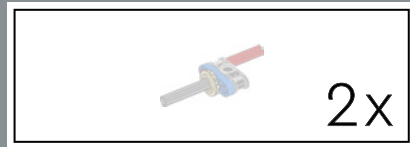
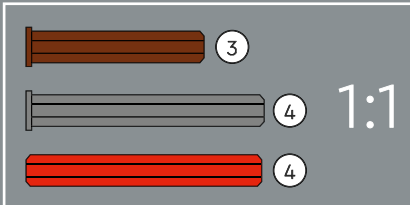
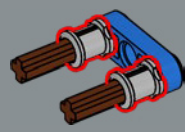

20

1

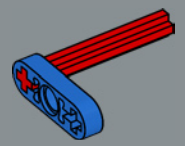

2

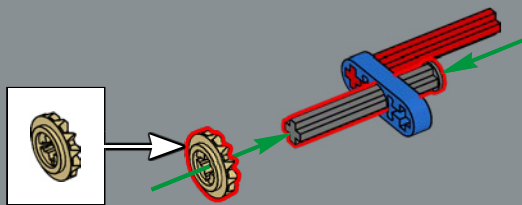

3

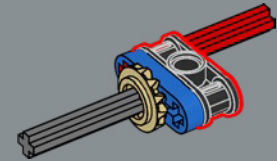

4

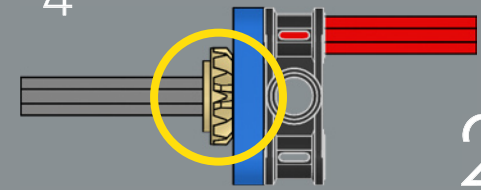

2x

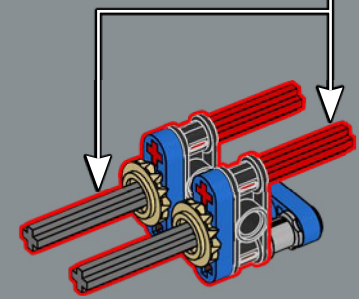

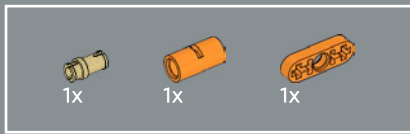

21

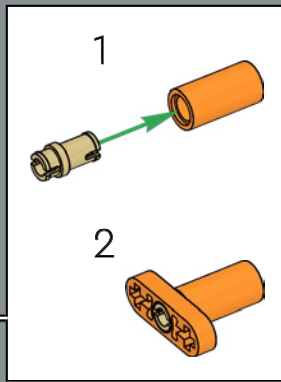
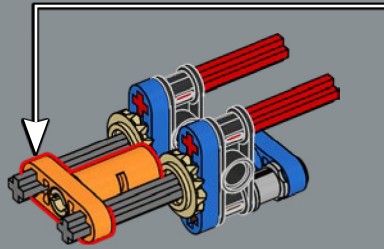

23

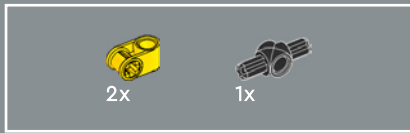
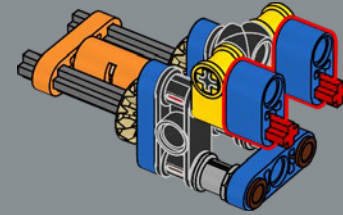

22

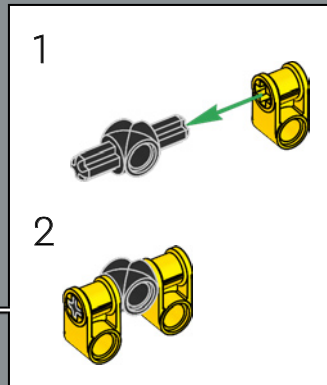
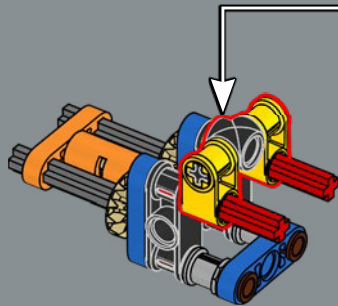

24

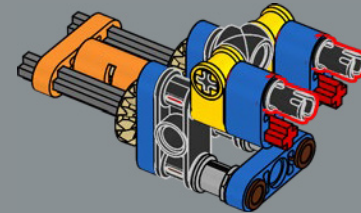

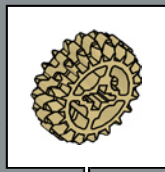
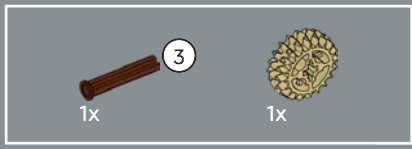

25

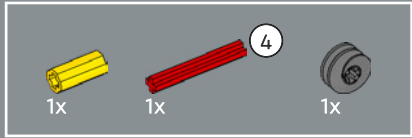
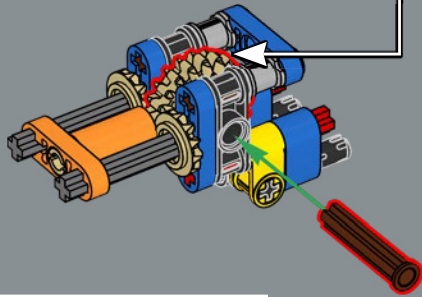

26

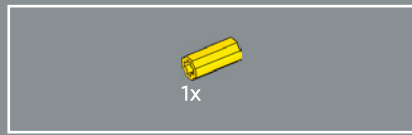
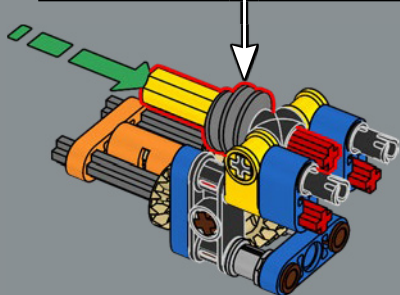
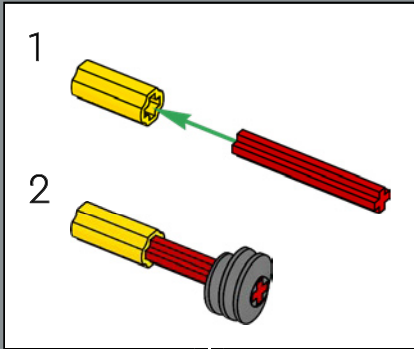

27

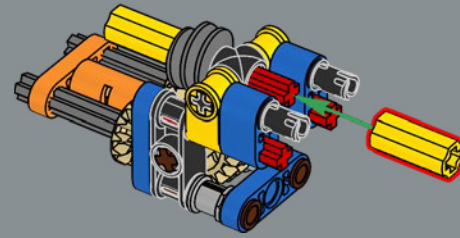
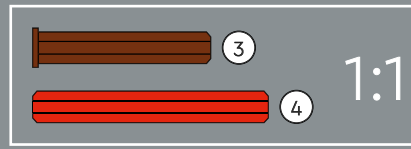

28

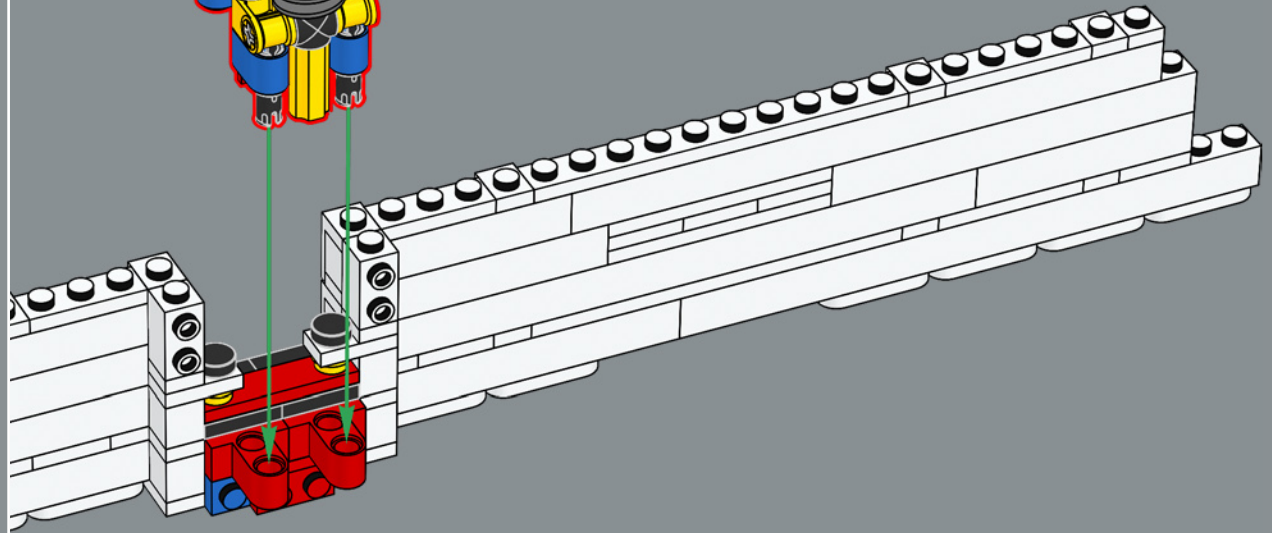
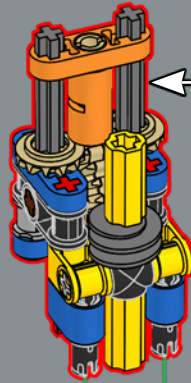

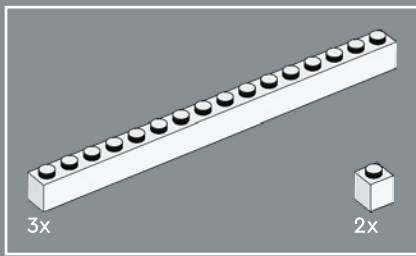

29

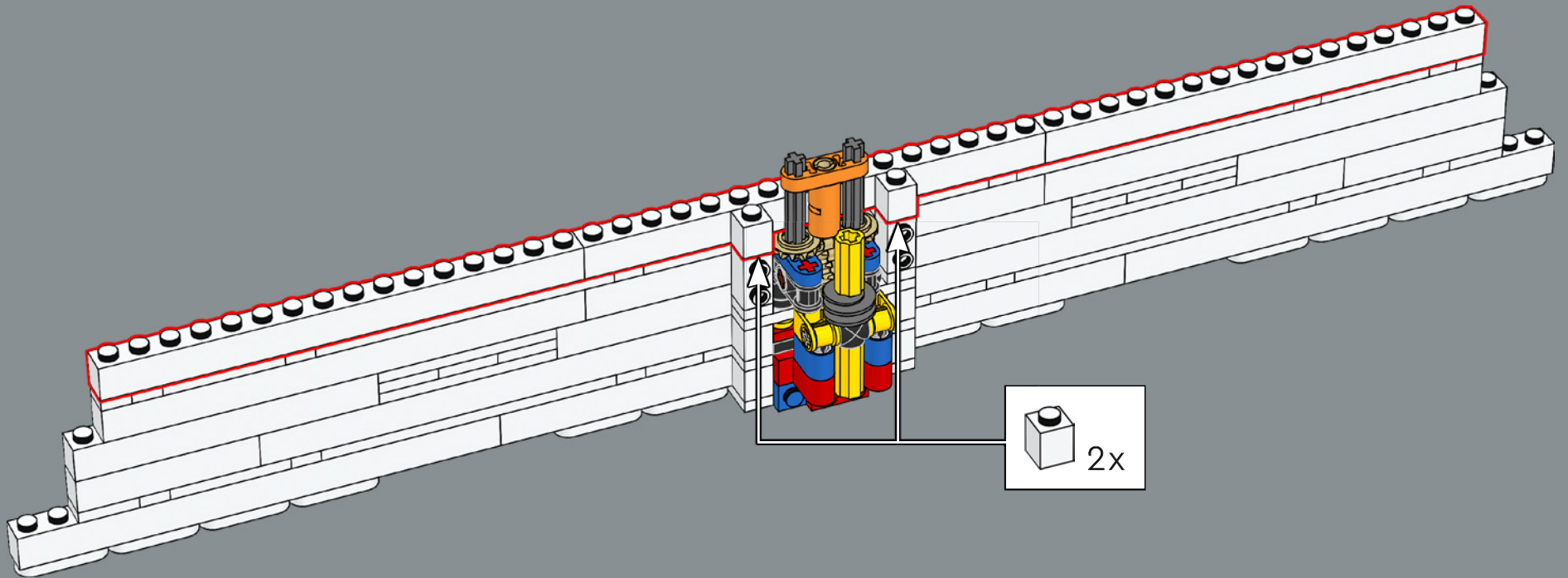



协和式飞机标志性三角翼下方的这些整流罩包含控制飞机升降副翼的作动器。

30

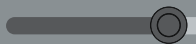
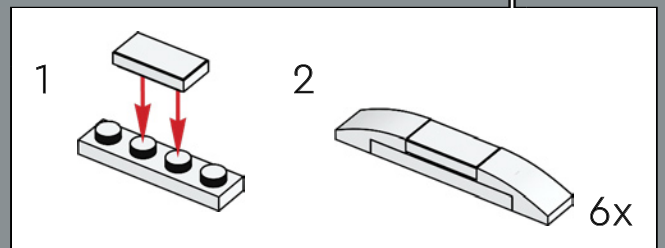
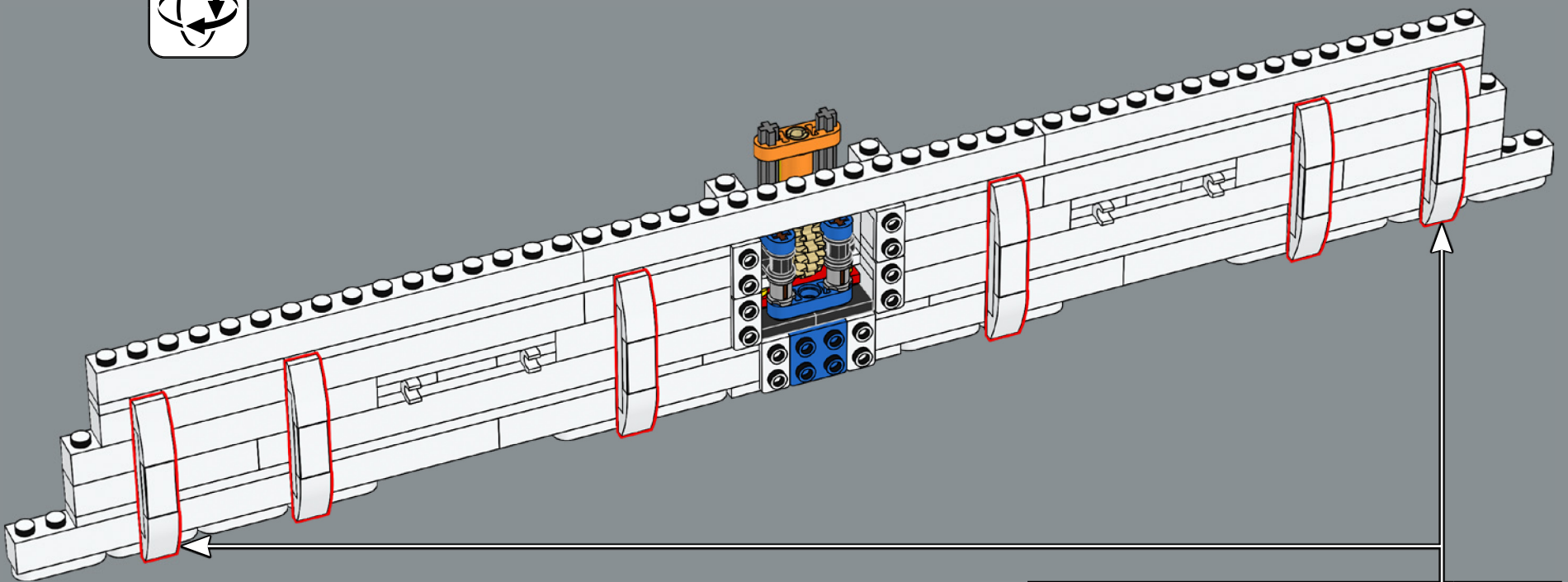

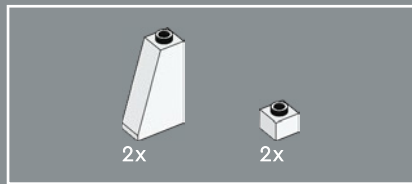

31

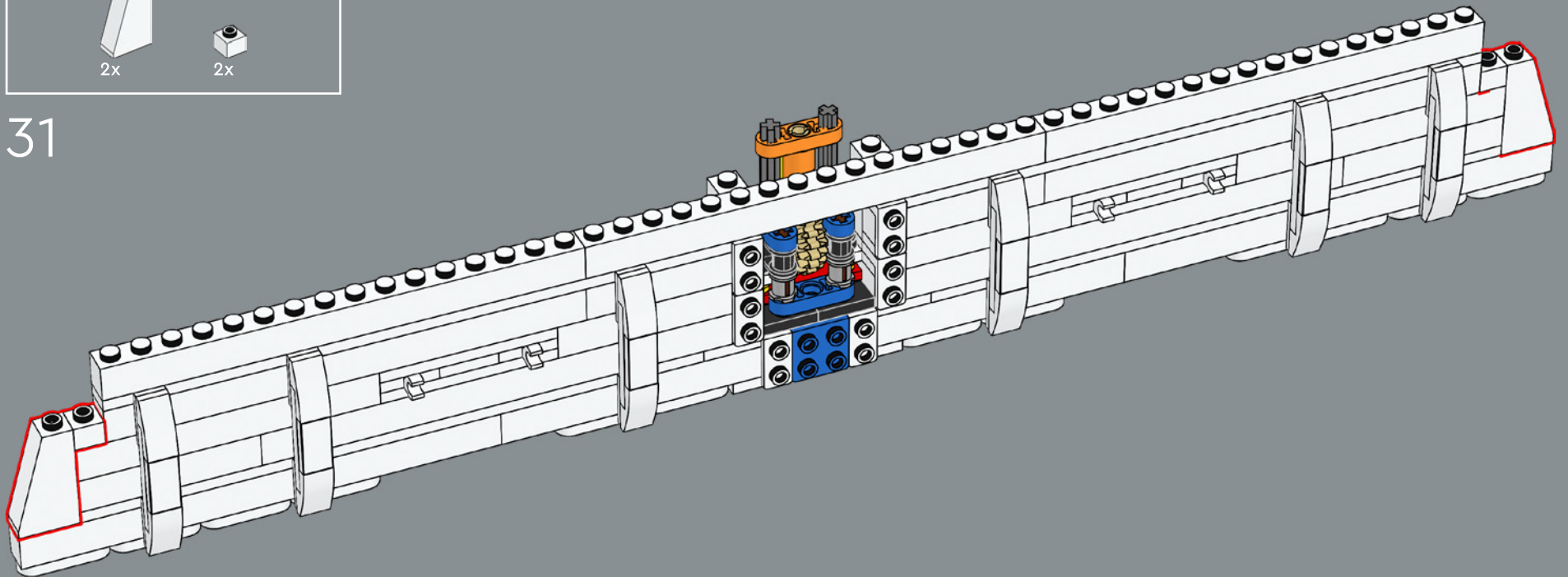



32

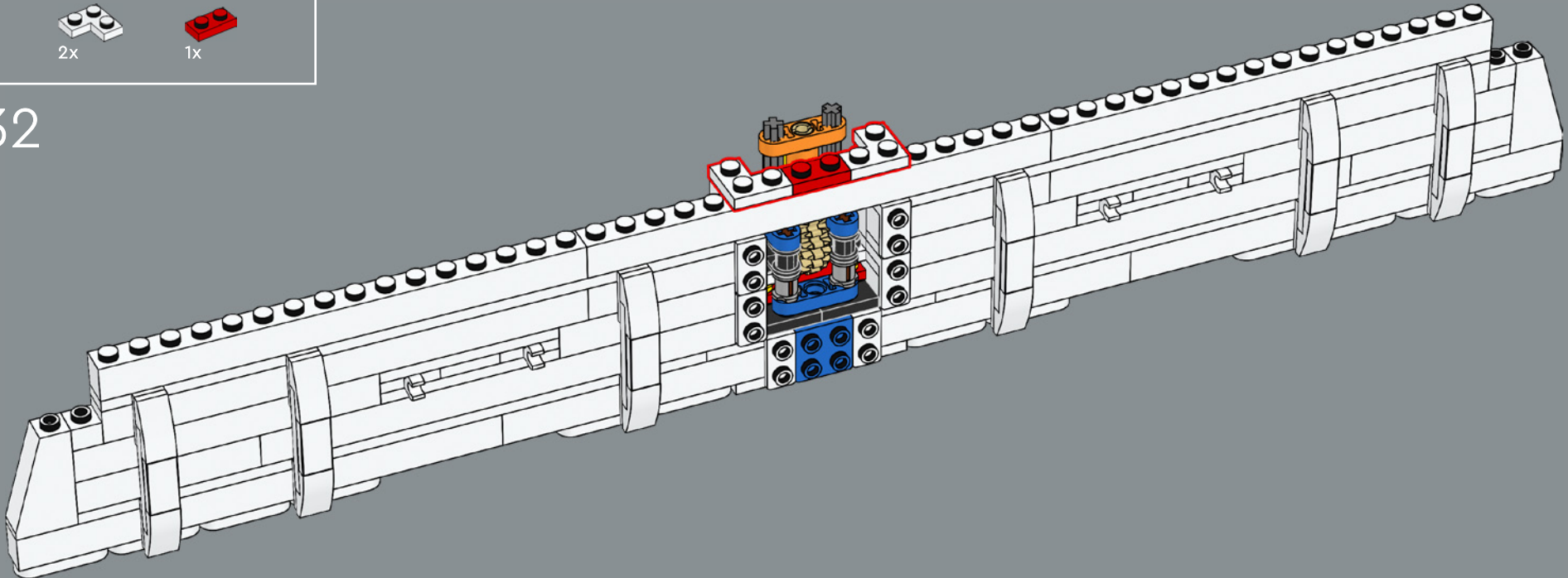

33

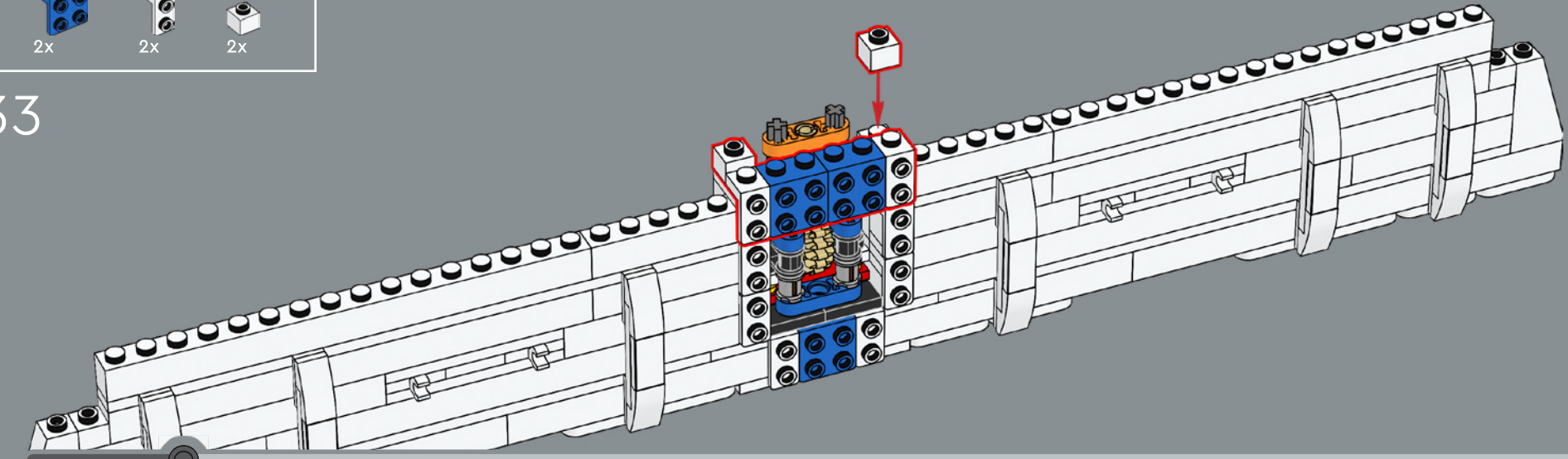

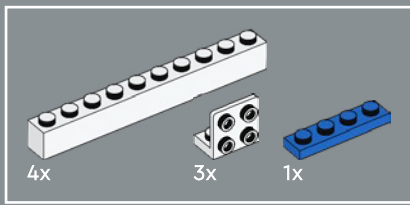

34

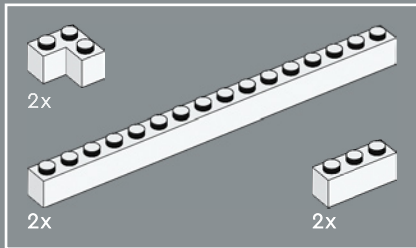
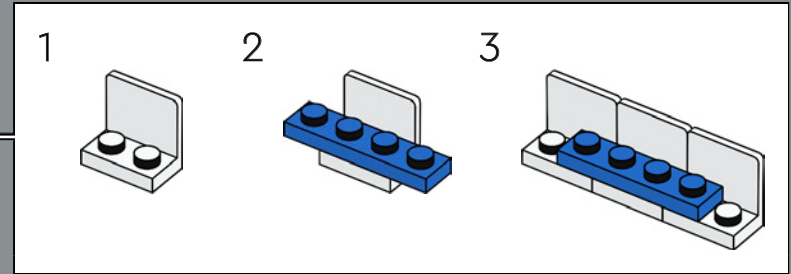
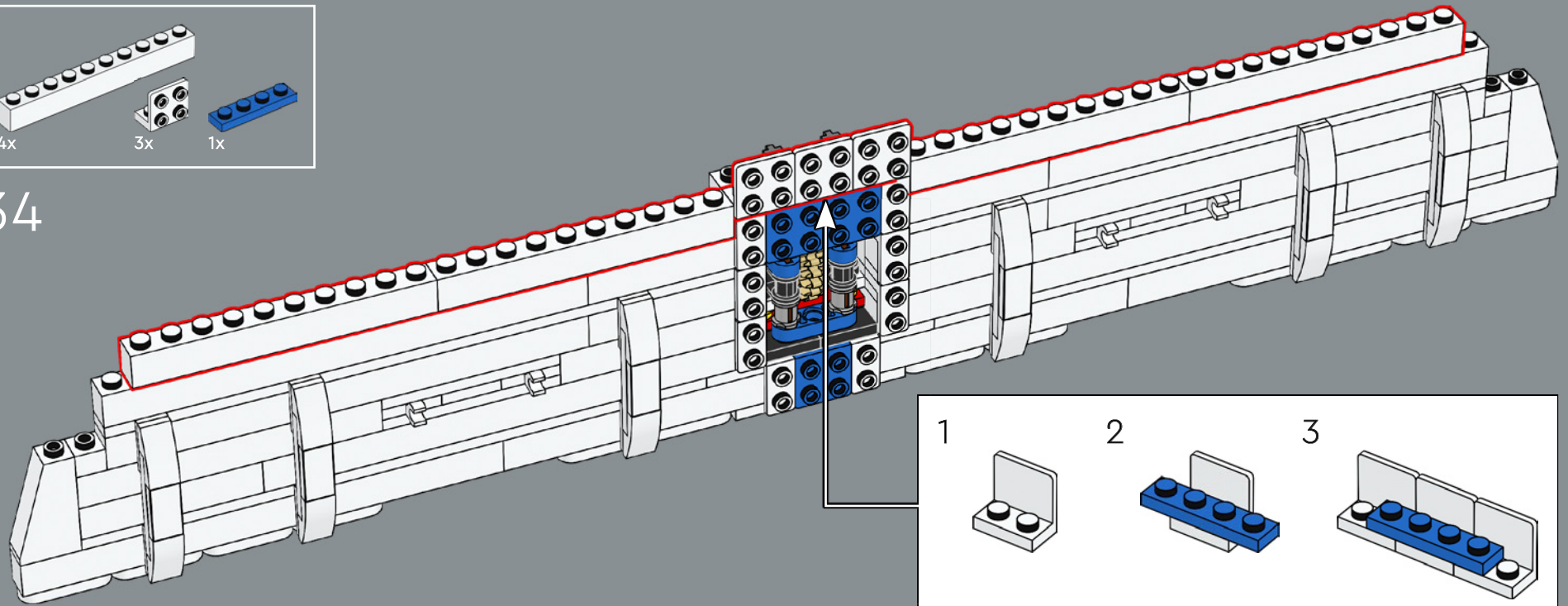

35

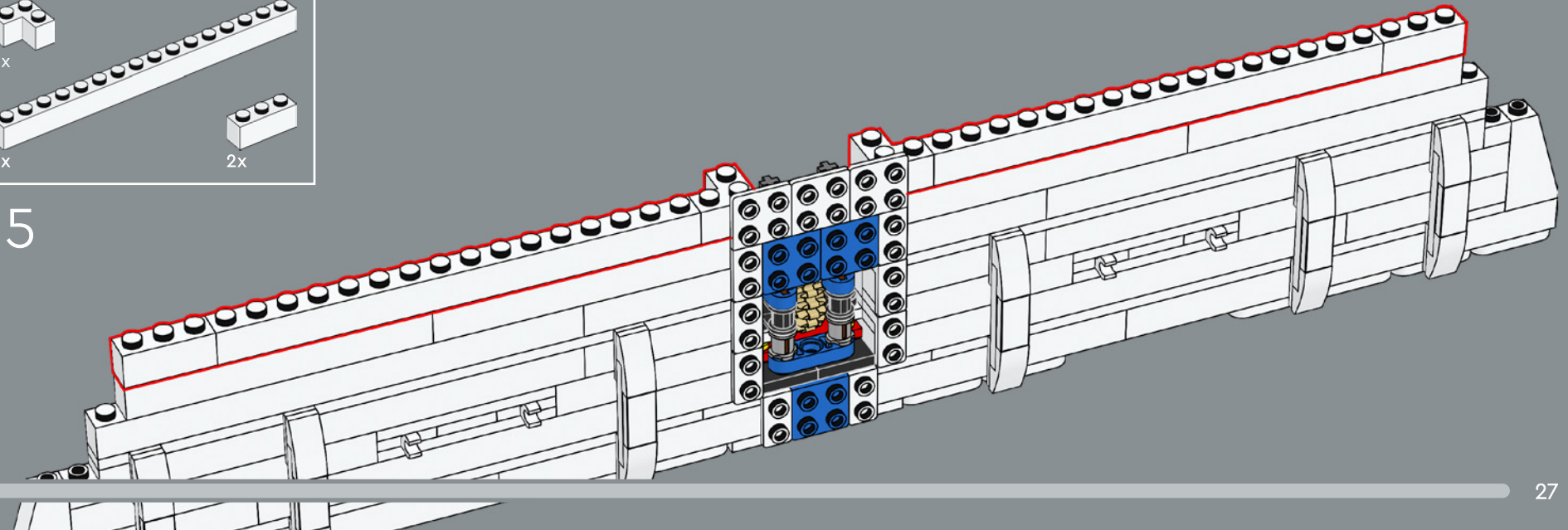

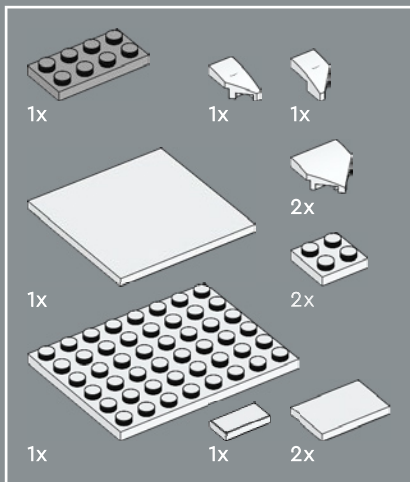

36

1

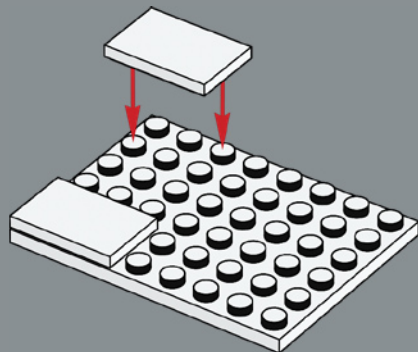

2

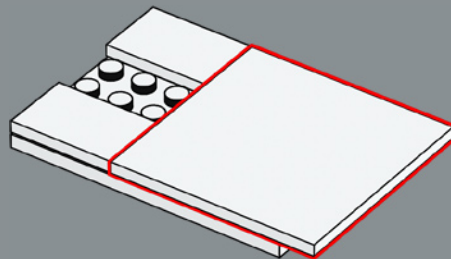

3

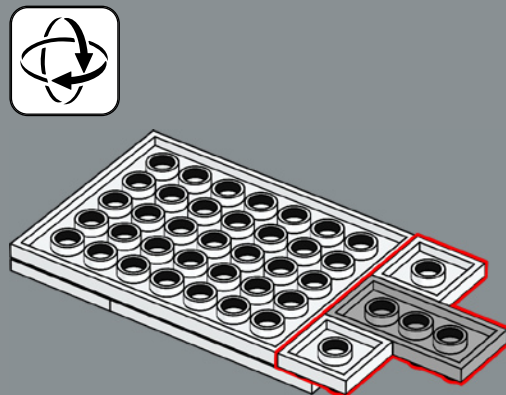

4

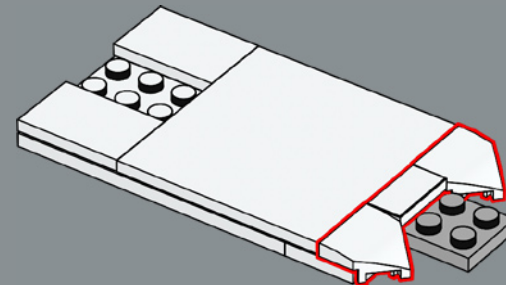

5

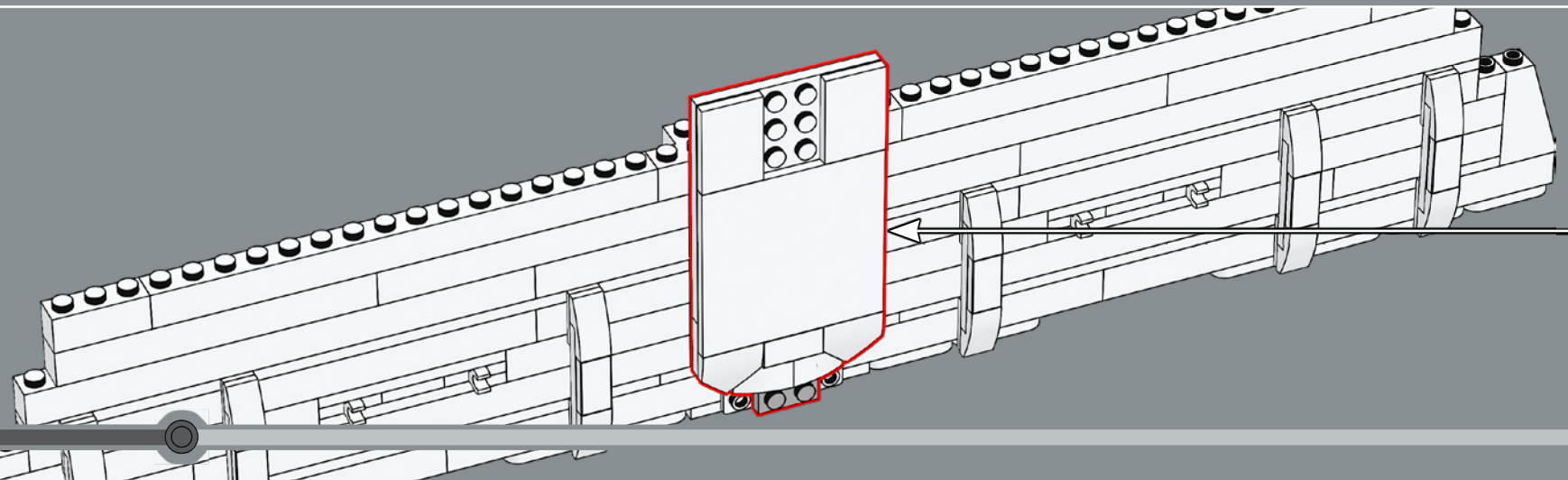
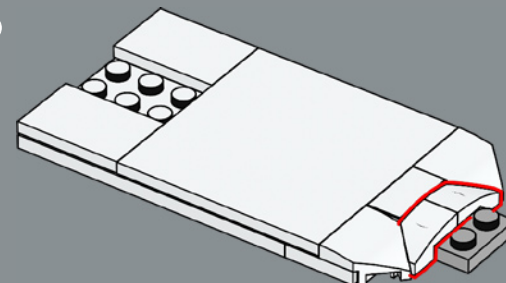

37

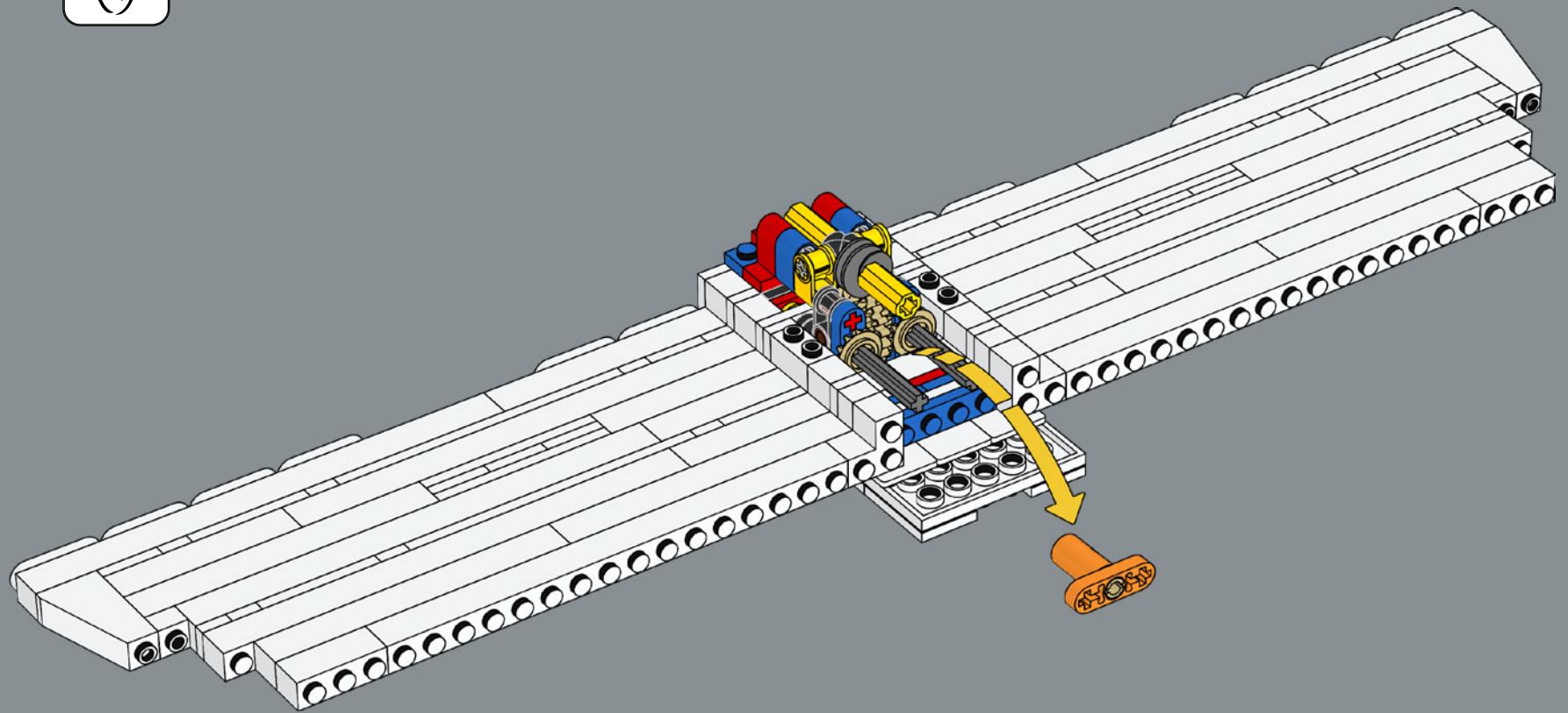

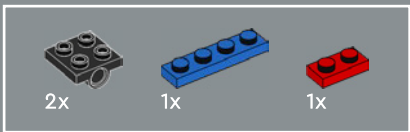

38

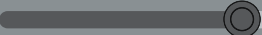
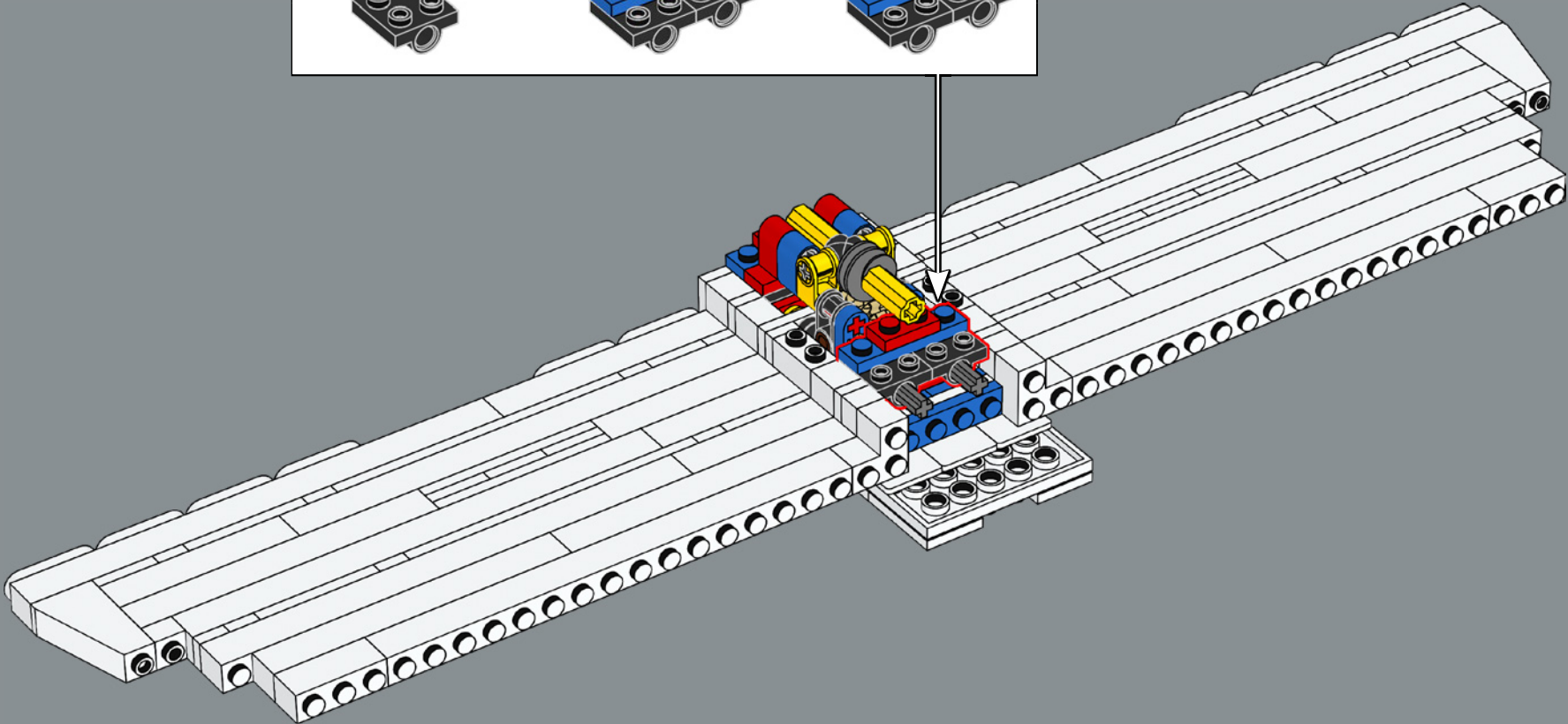
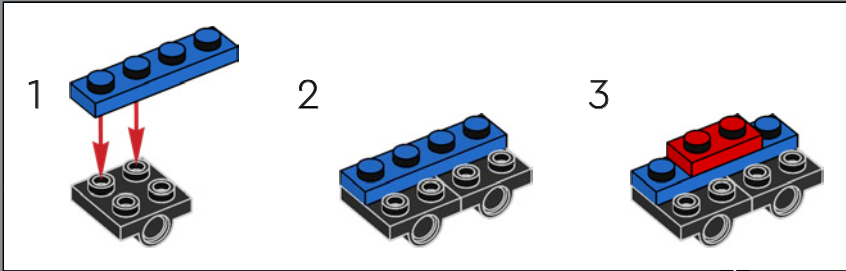

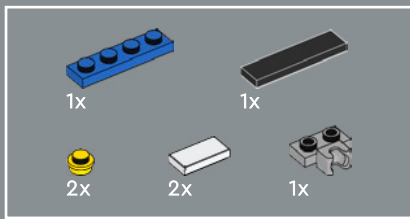

39

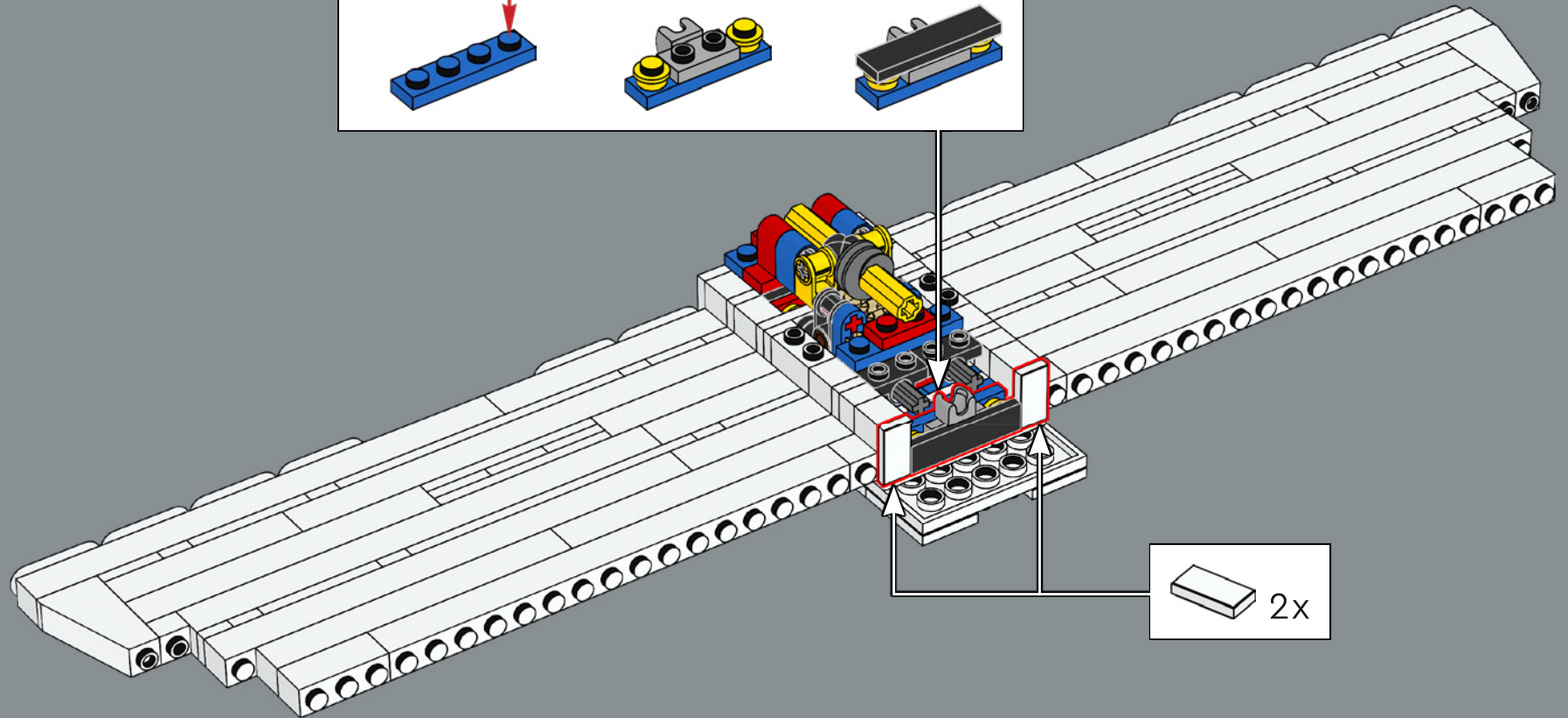
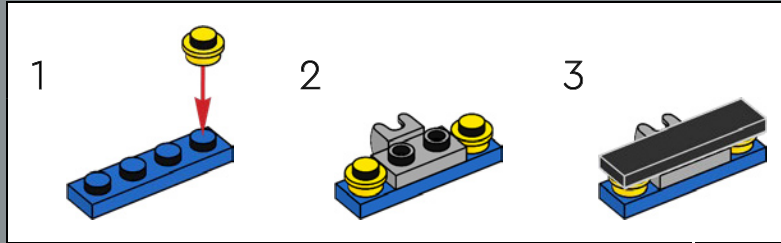

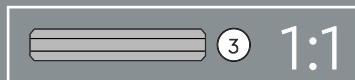
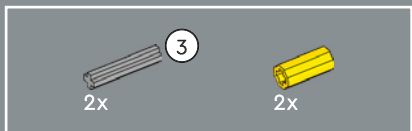

协和式飞机包含 30.6 公里 (19 英里) 的布线。
我们选择了几米长的乐高®积木。

40

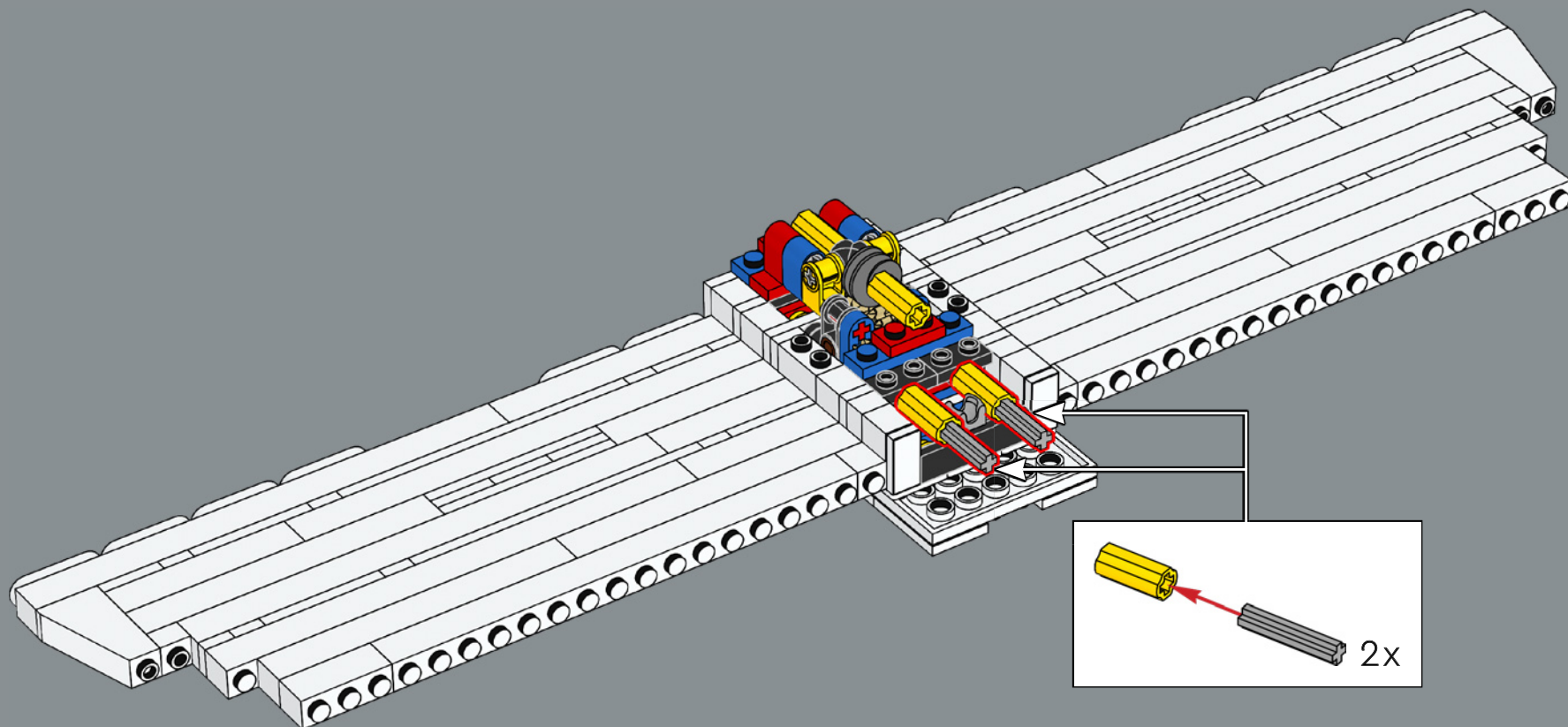

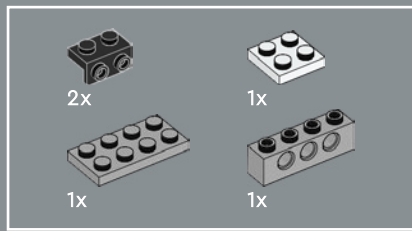

41

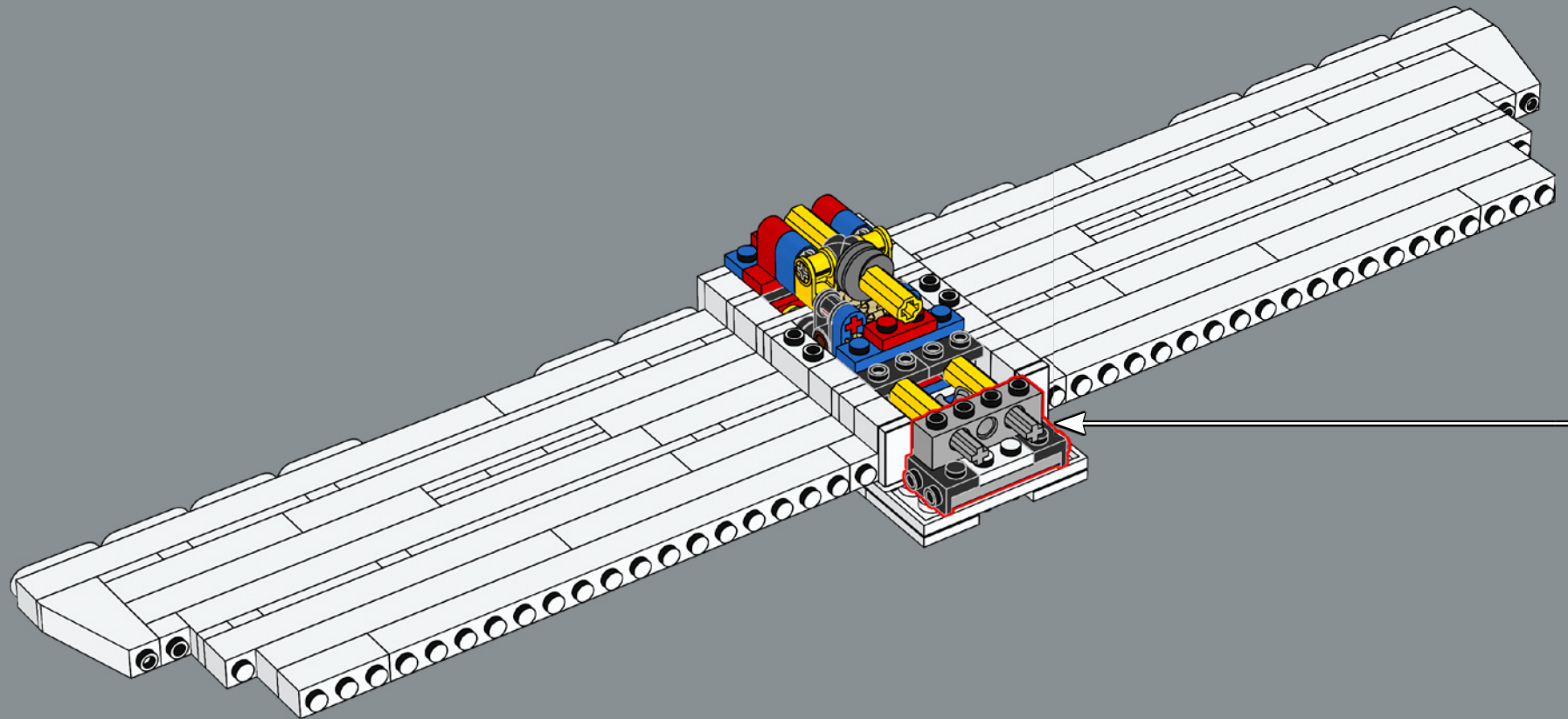
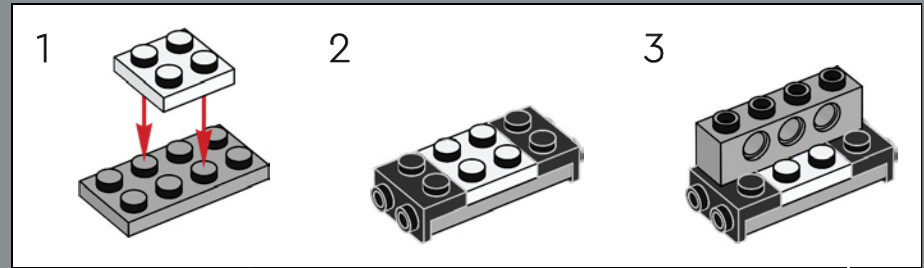

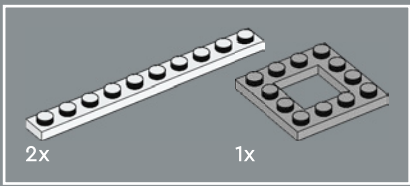

42

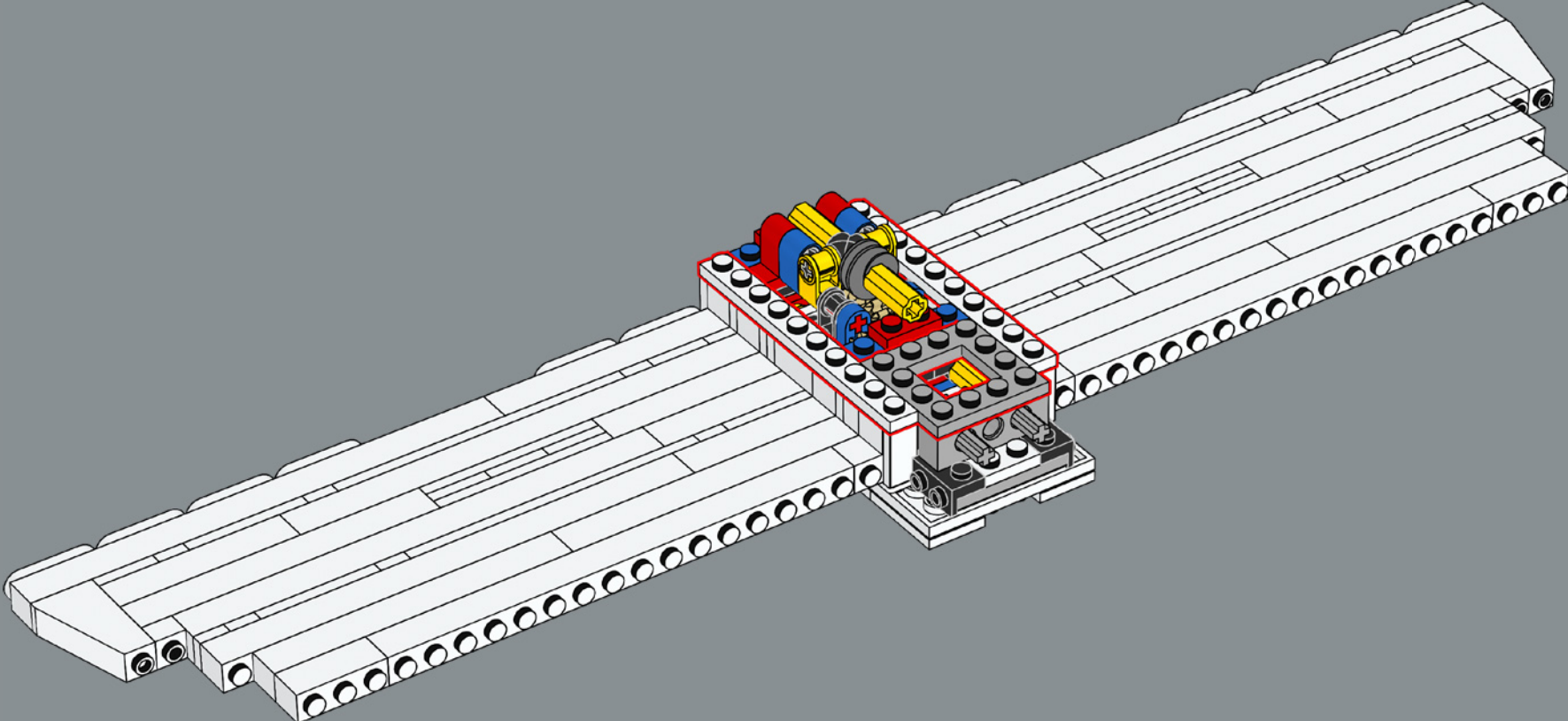

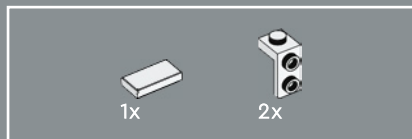

43

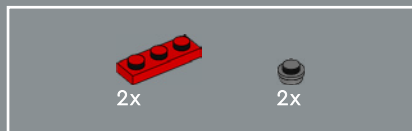
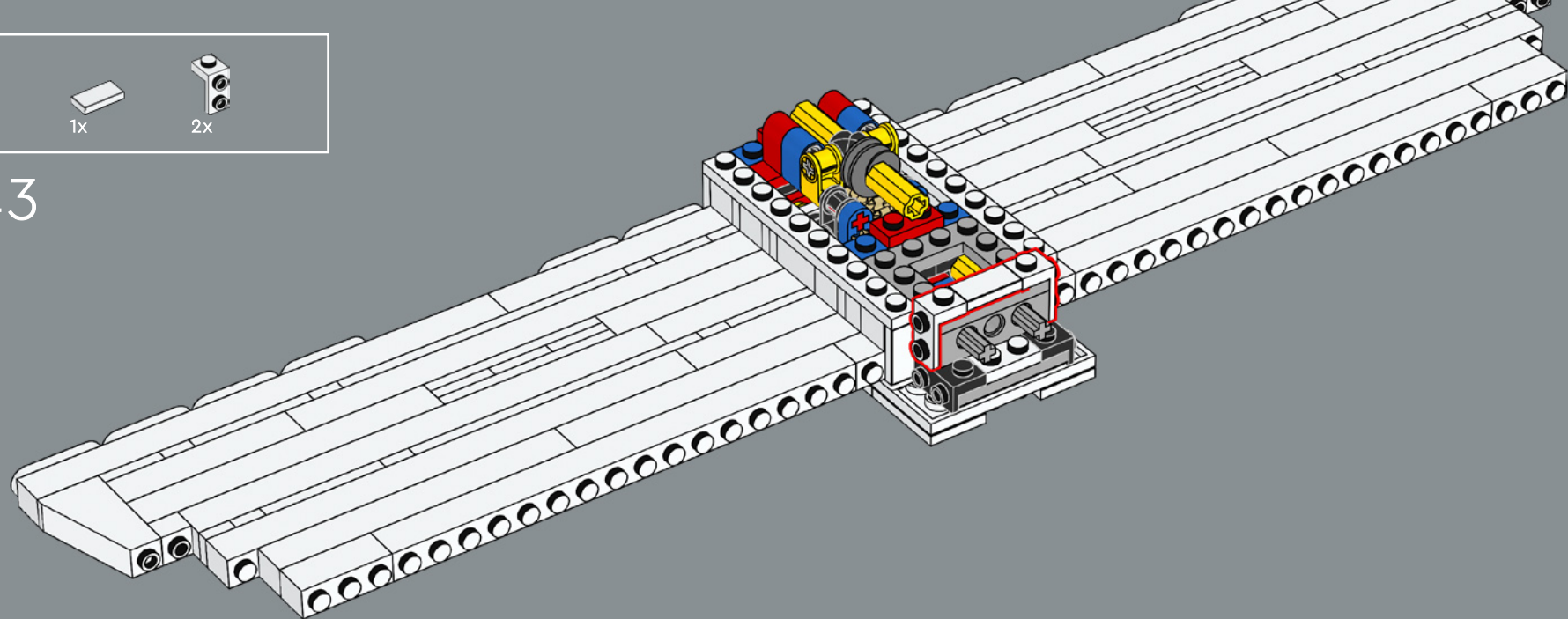

44

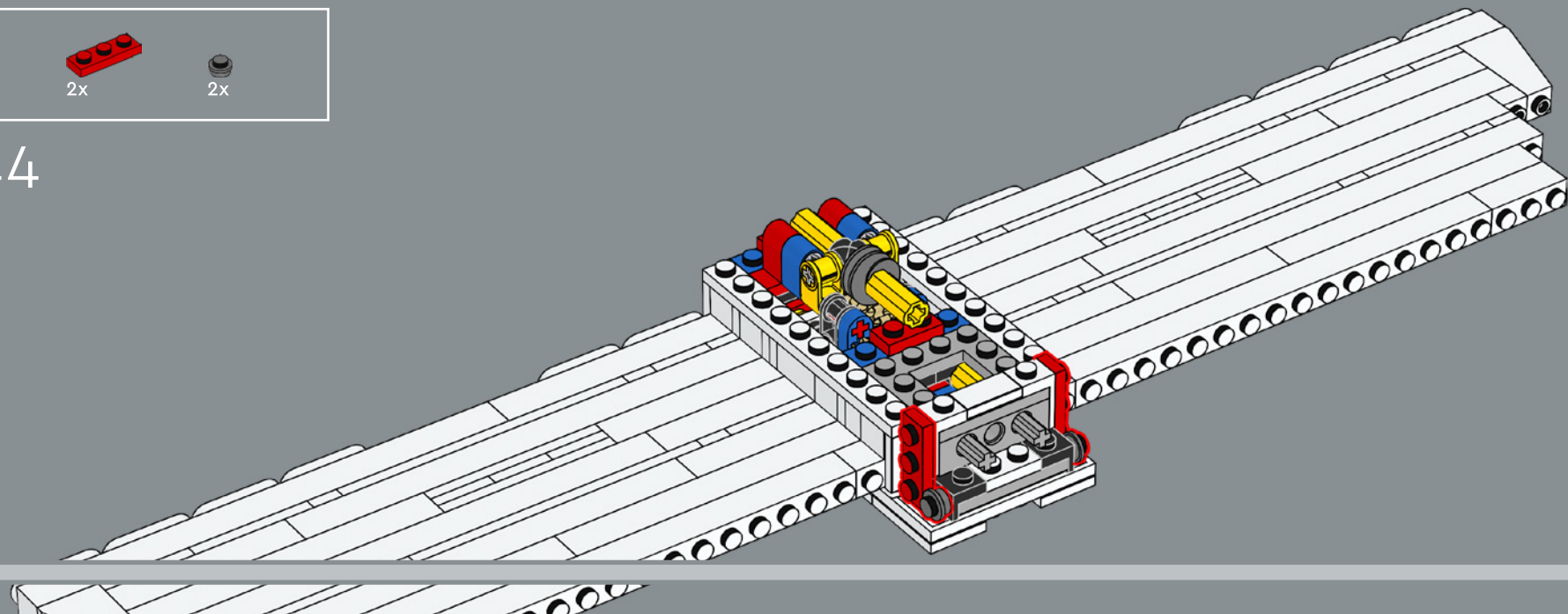

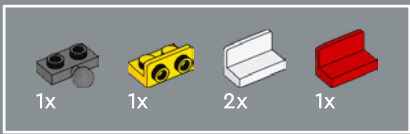

45

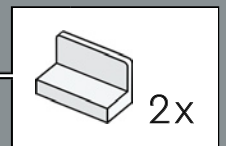
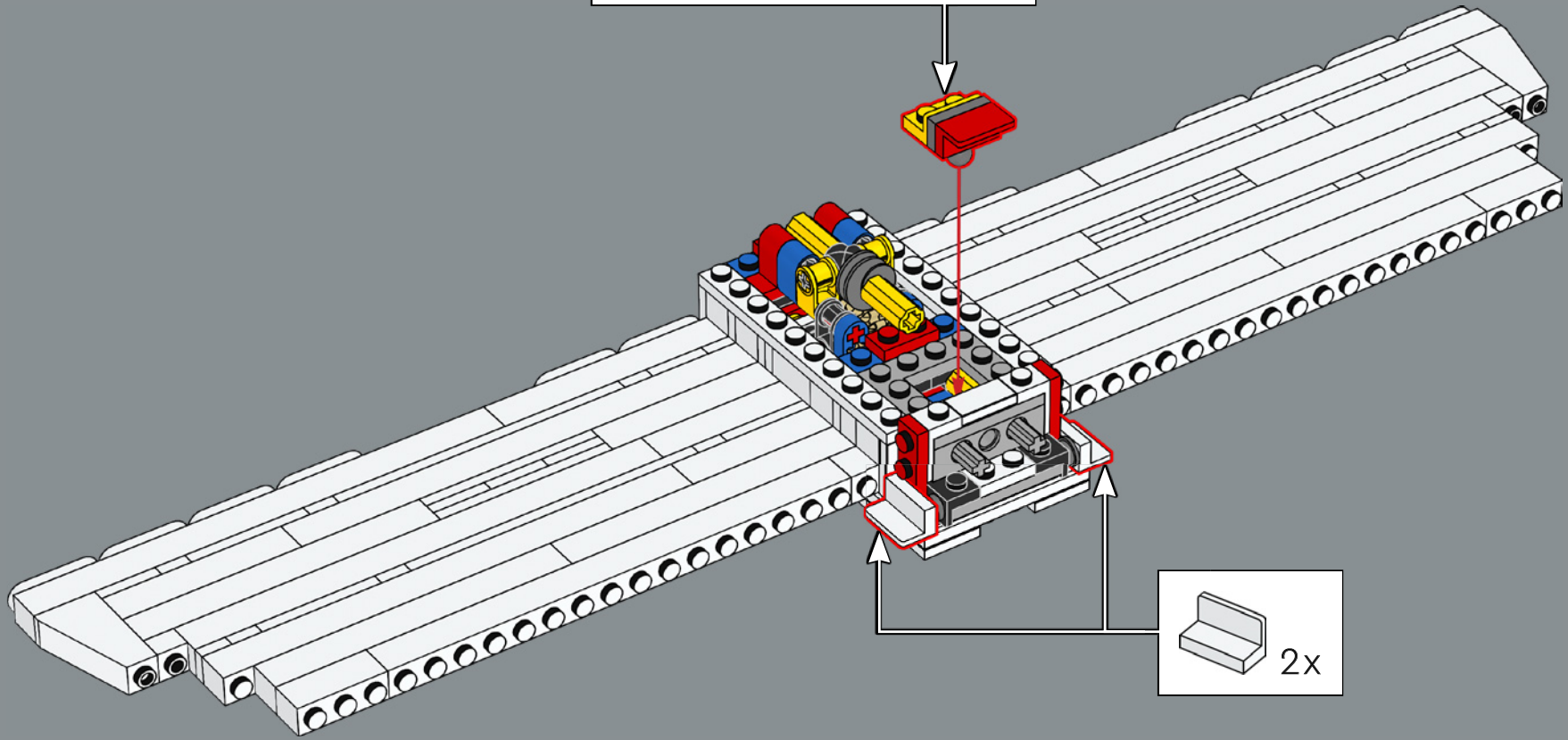
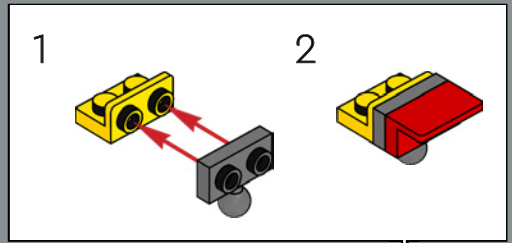



46

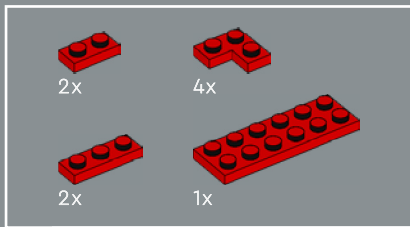
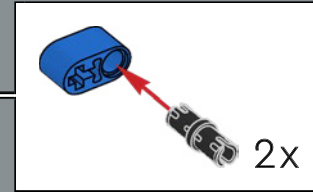
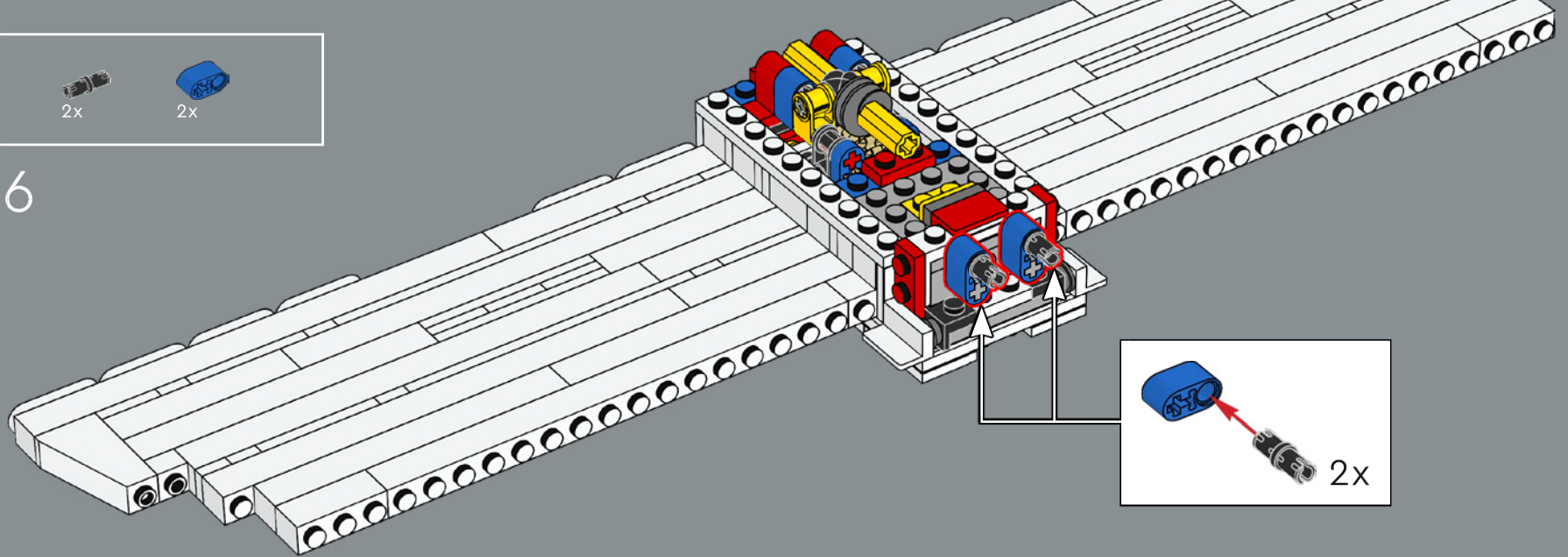

47

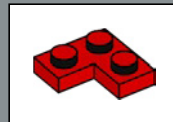
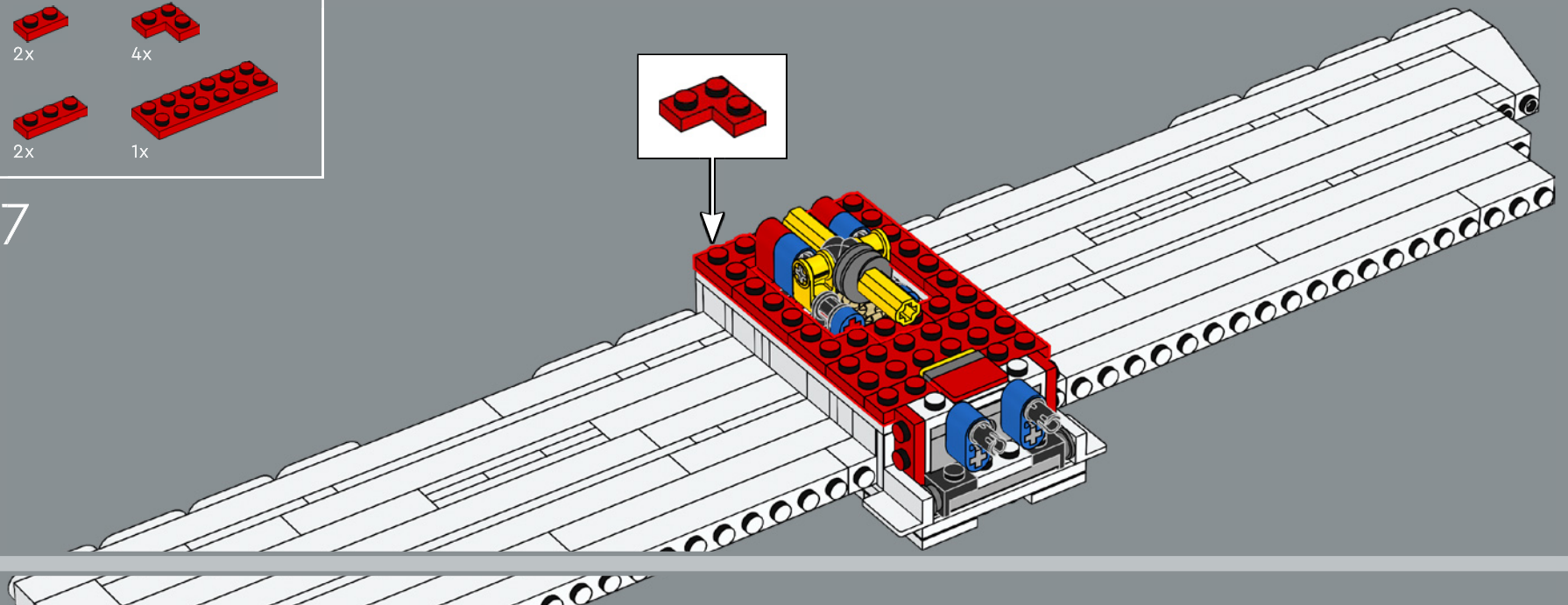

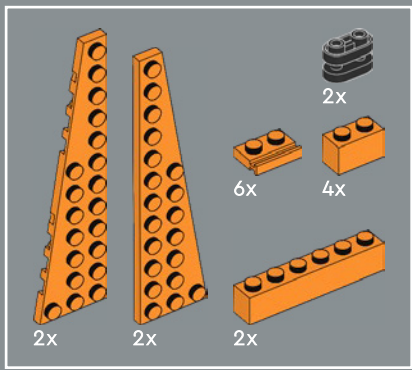

48

1

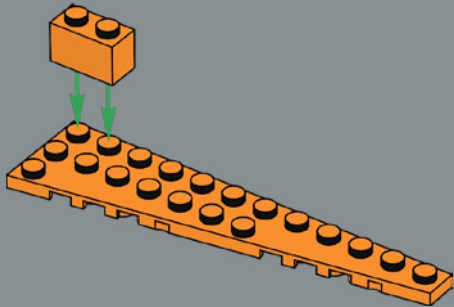

2

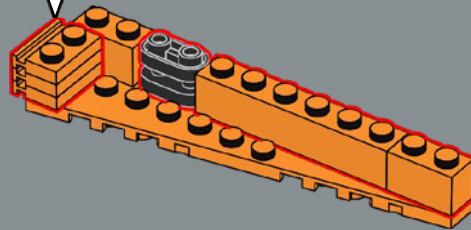
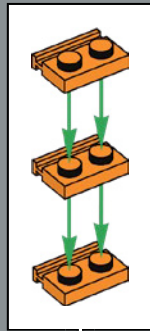

3

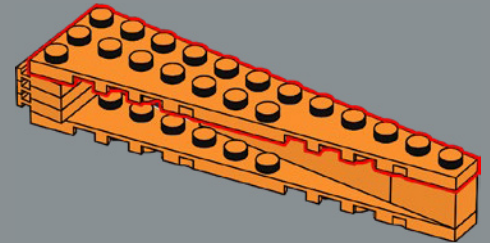

1

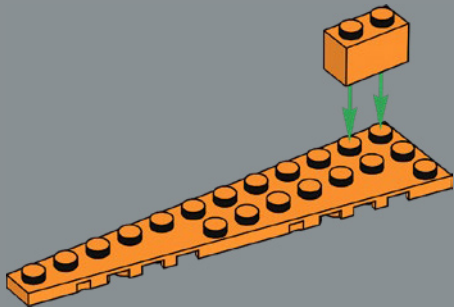

2

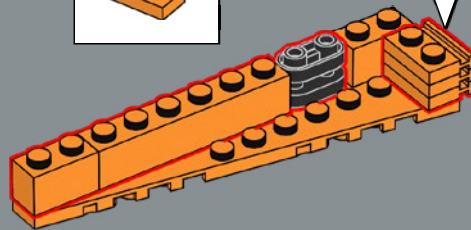
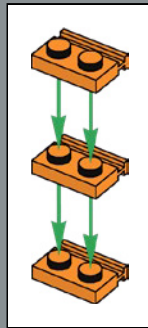

3

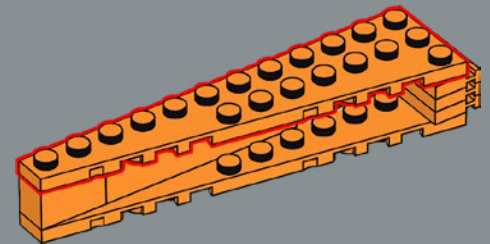

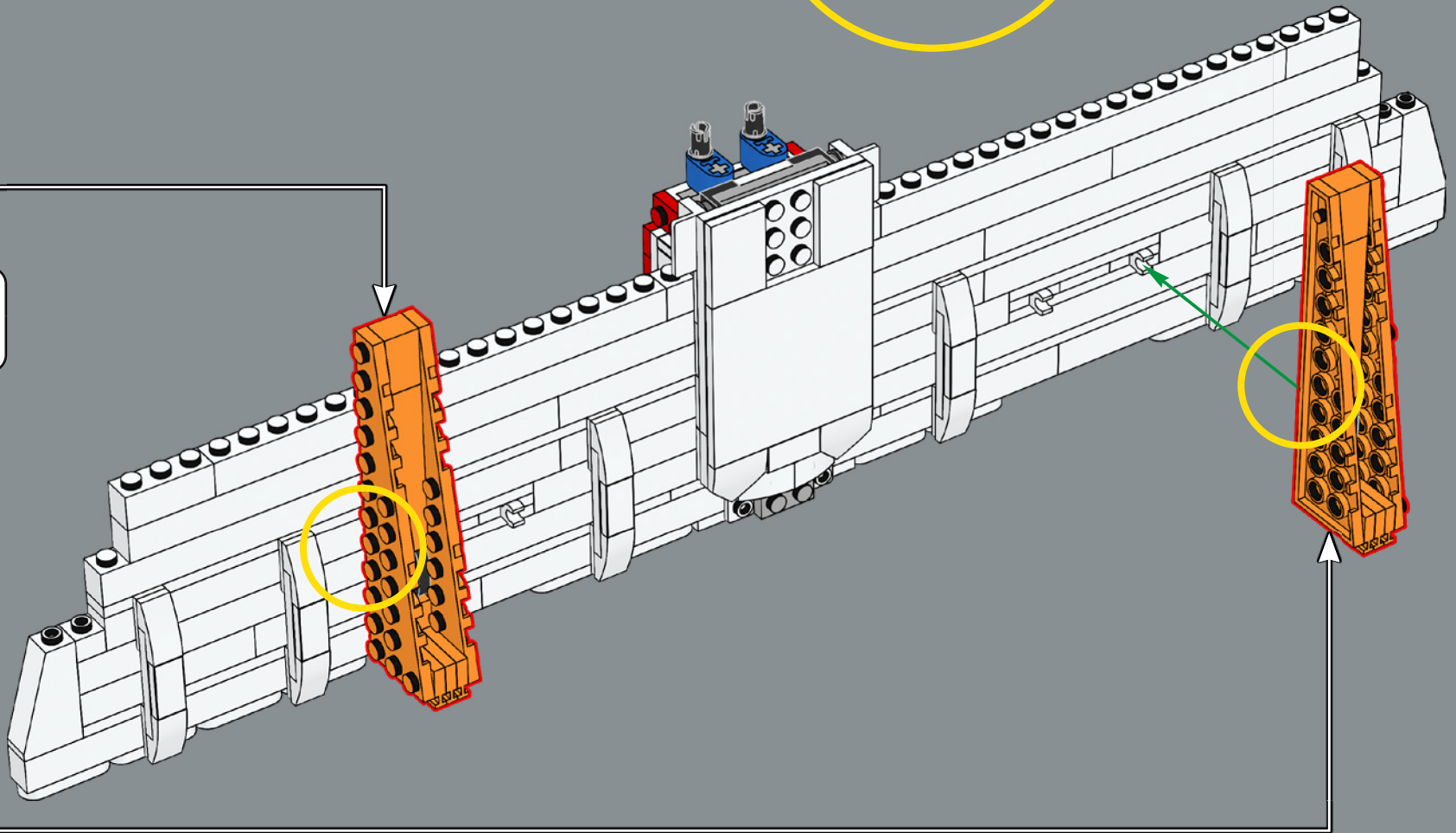

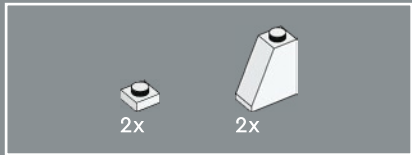

49

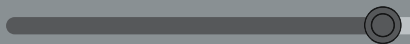
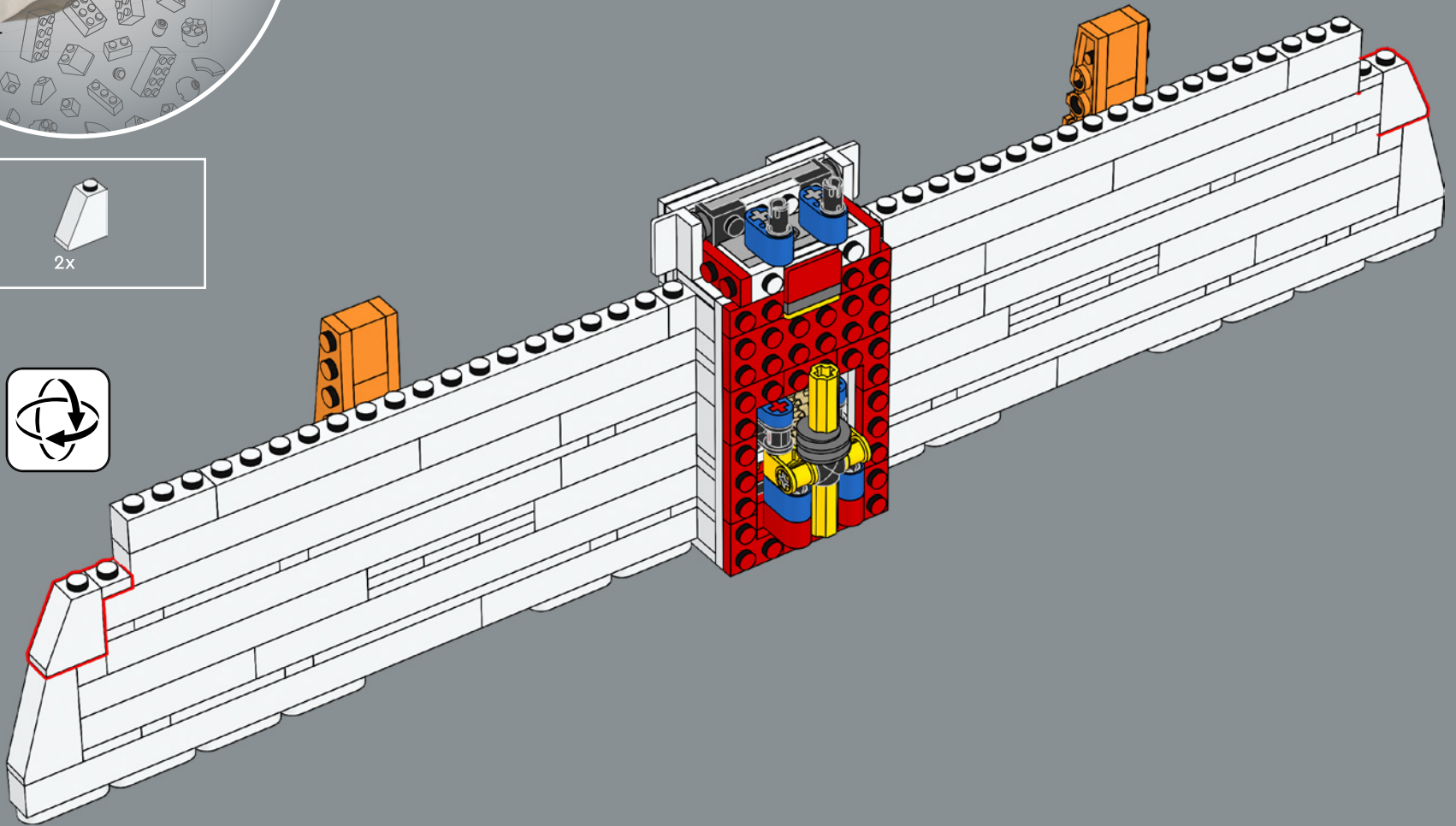

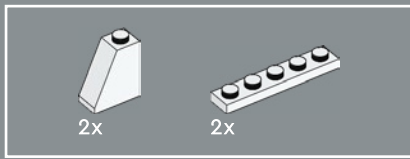

50

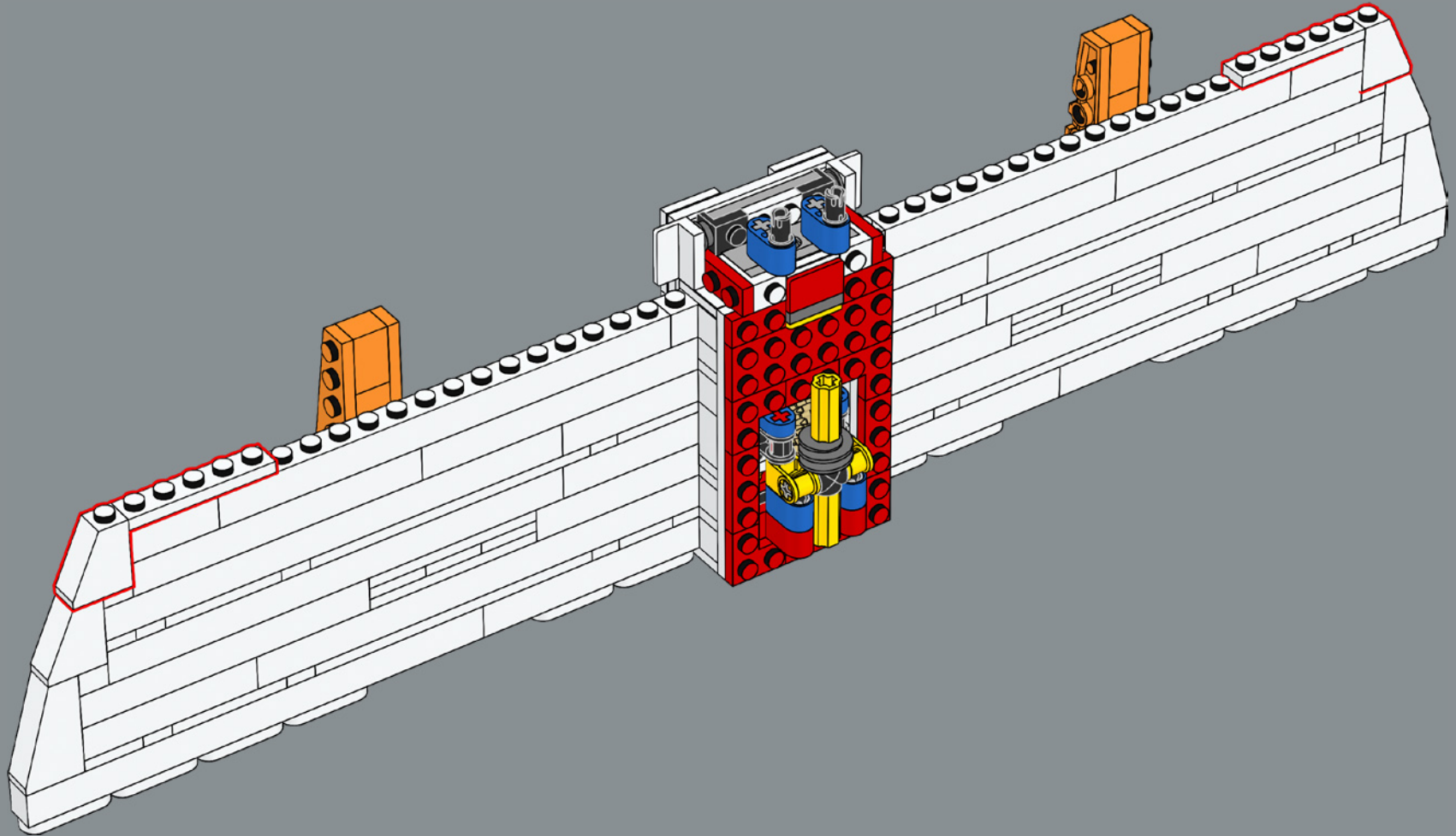

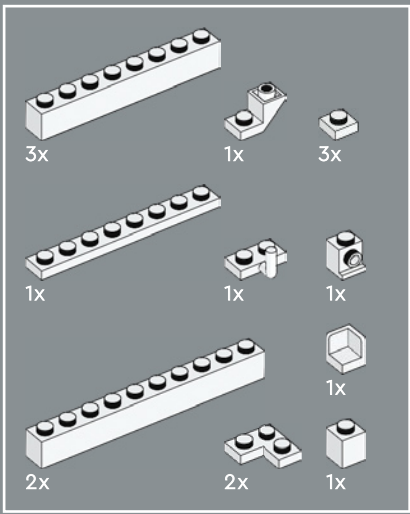

51

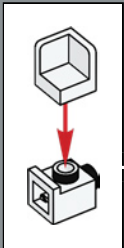
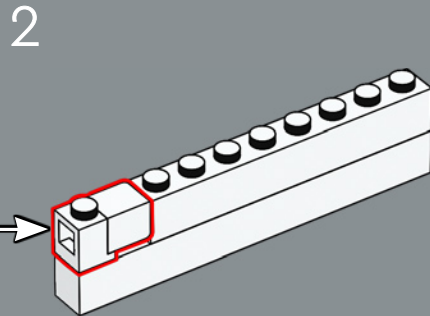
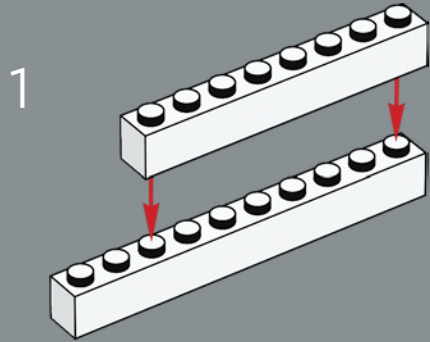

3

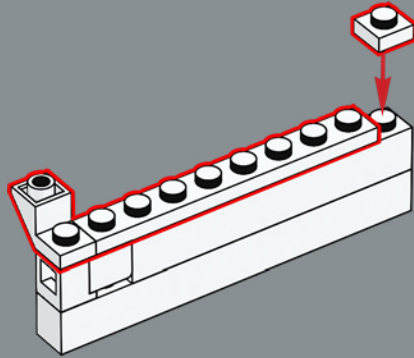

4

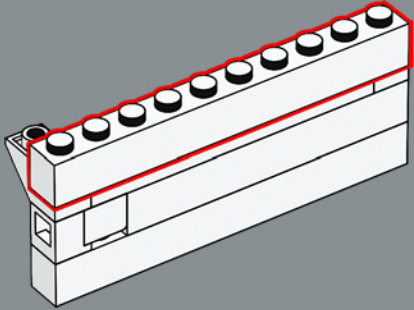

5

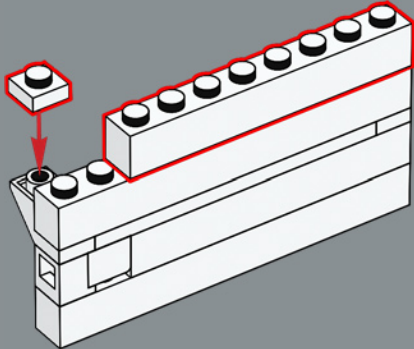

6

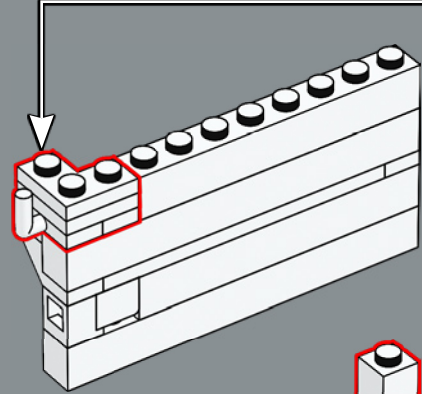

7

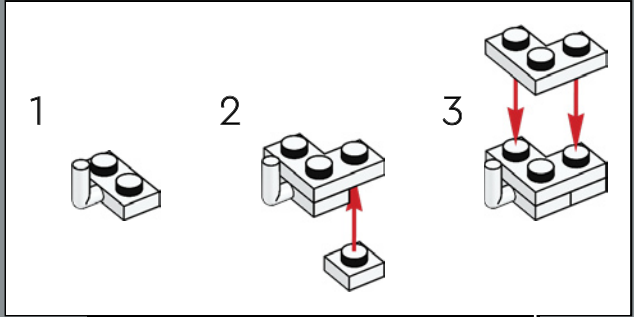
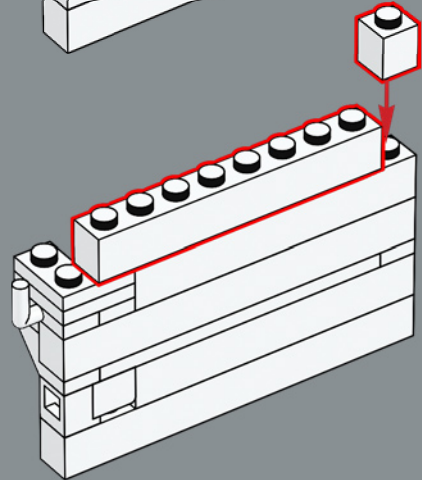

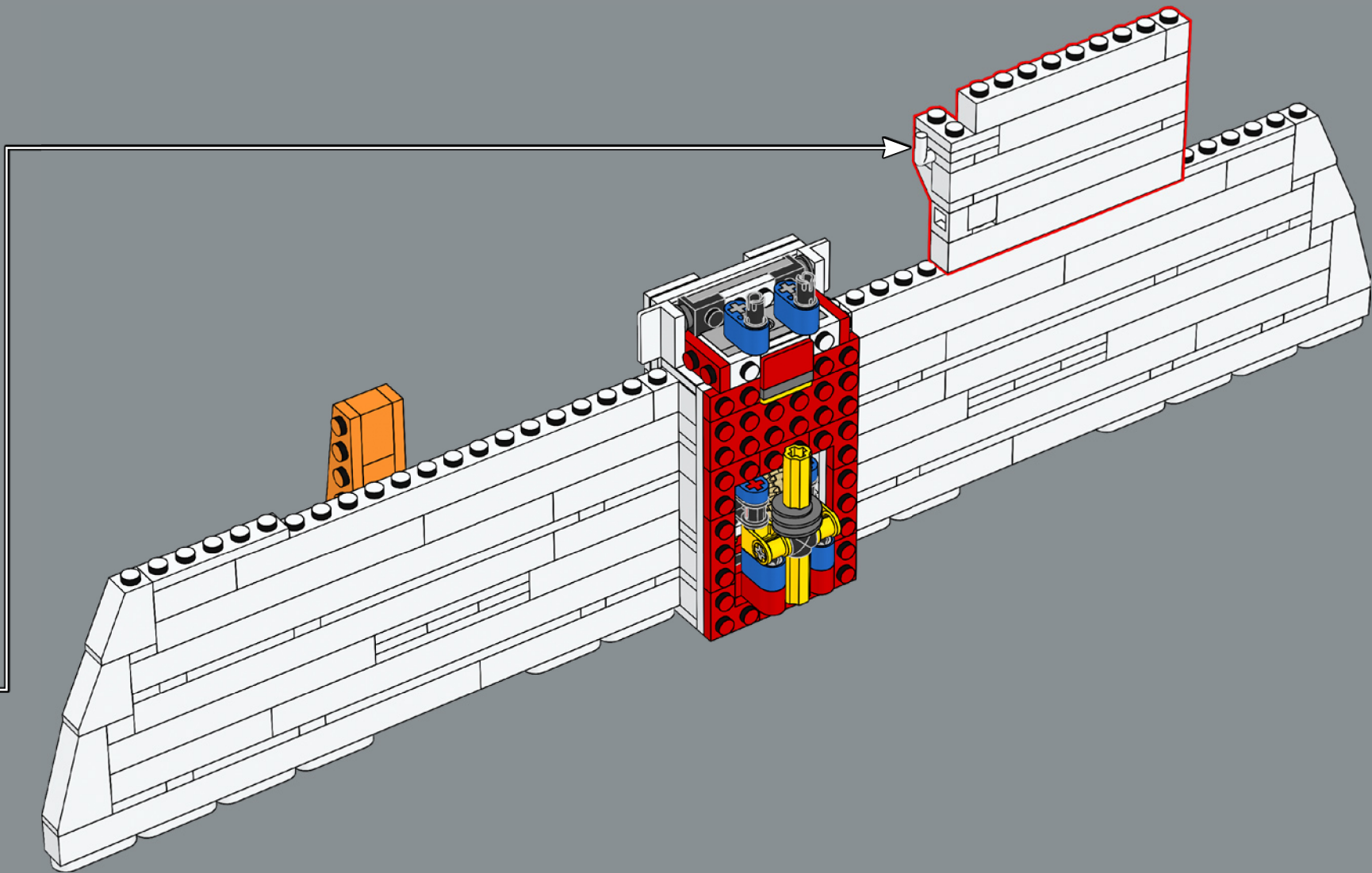

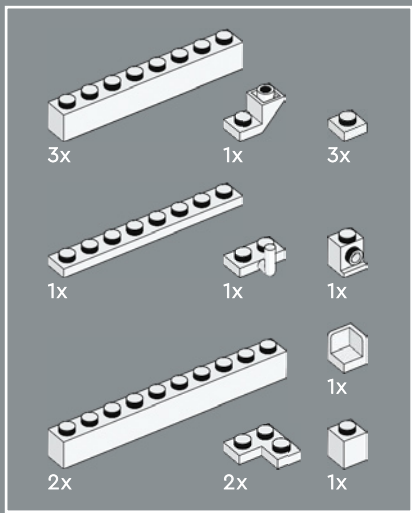

52

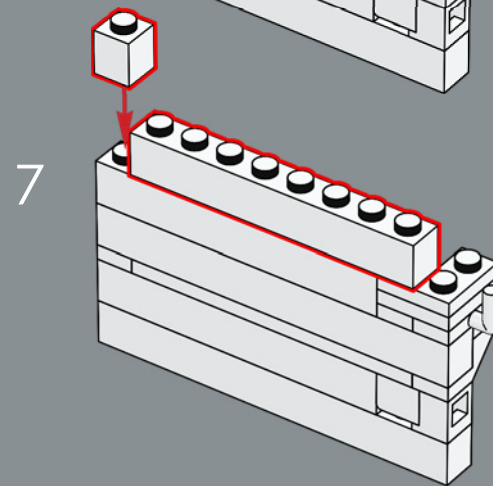
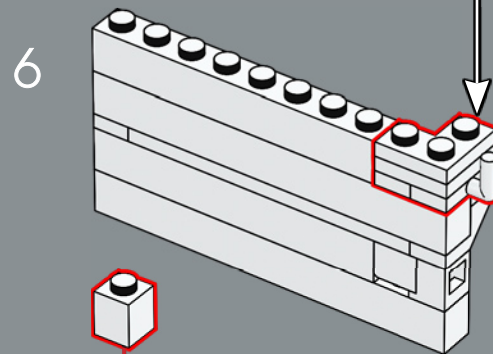
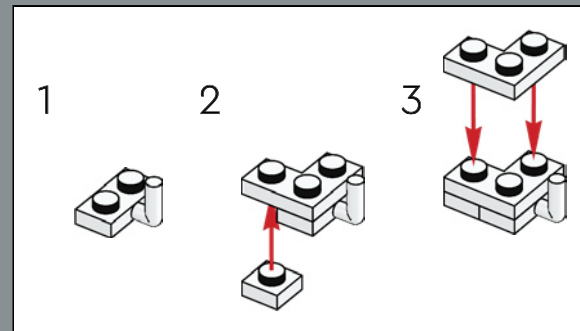
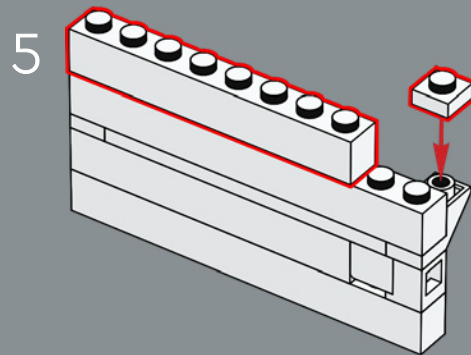
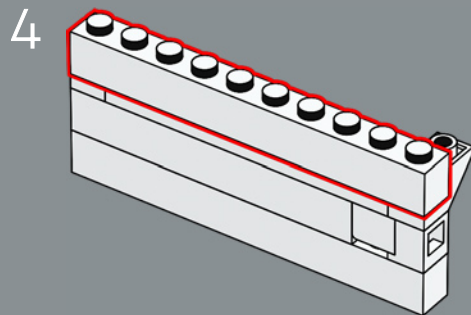
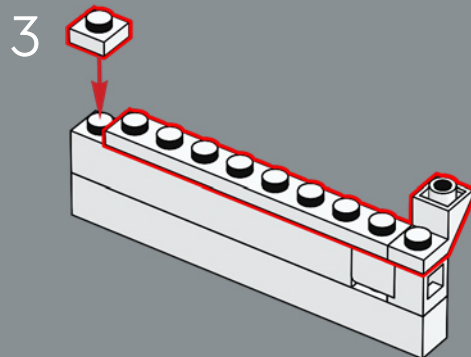
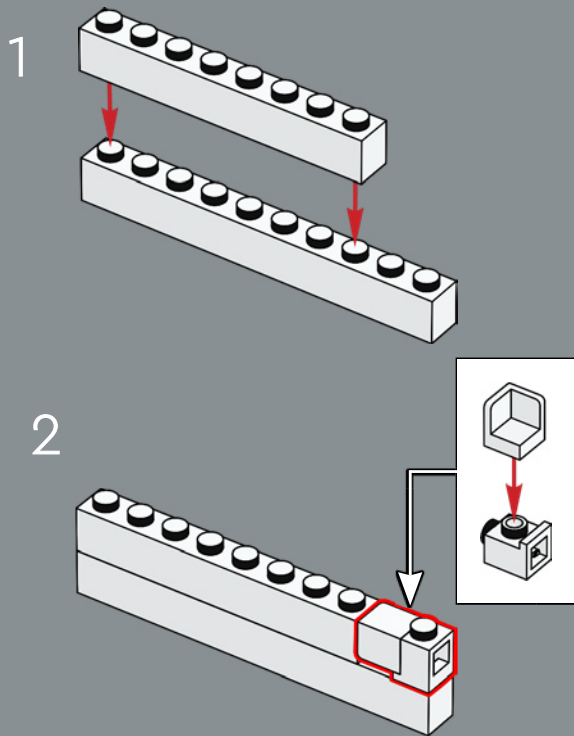

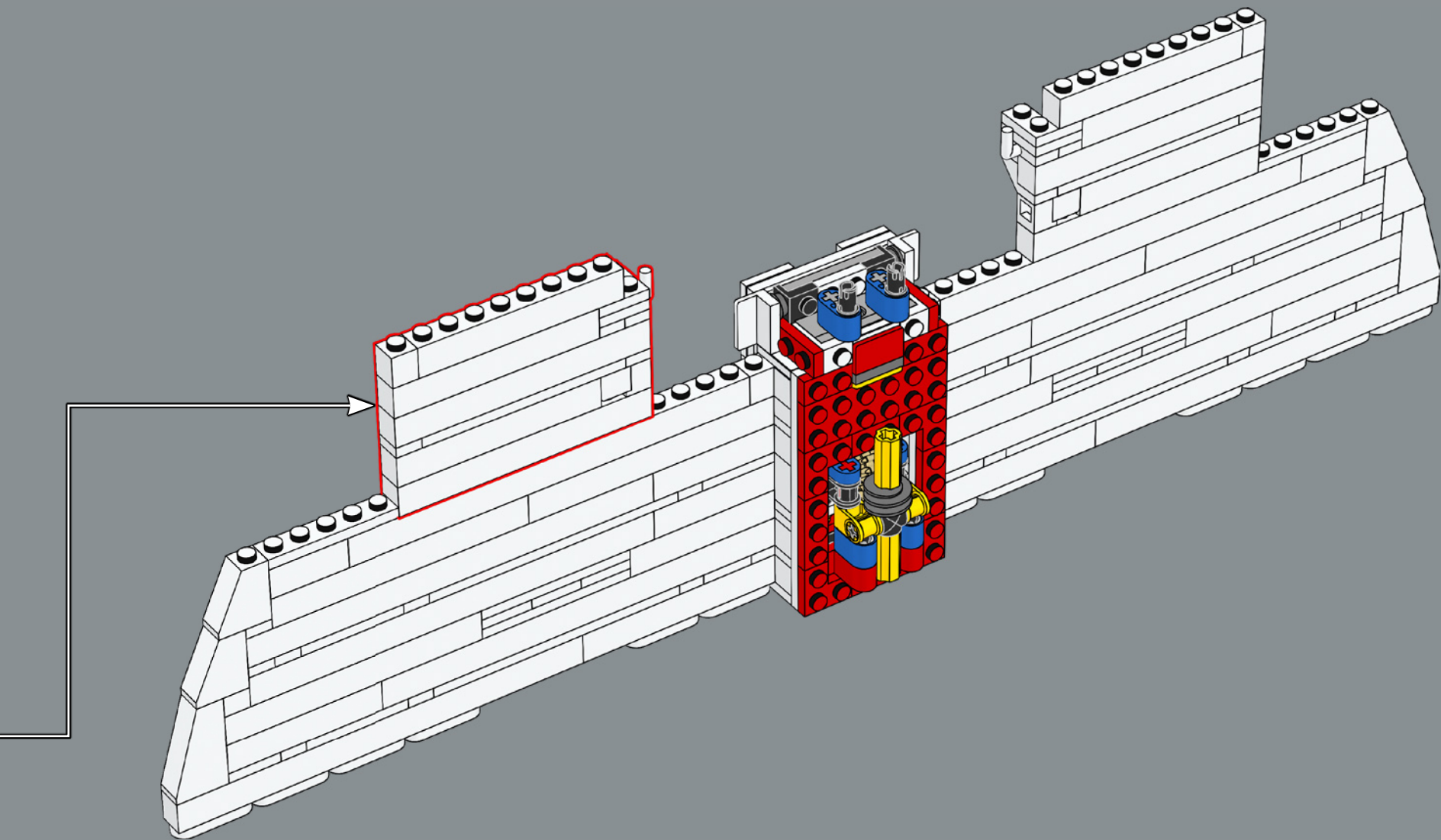

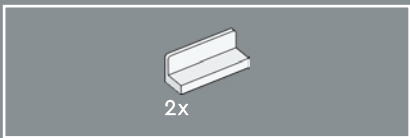

协和式飞机采用三点式起落架布局。
你现在正在拼搭的机构将触发位于三角翼中间的主起落架。

53

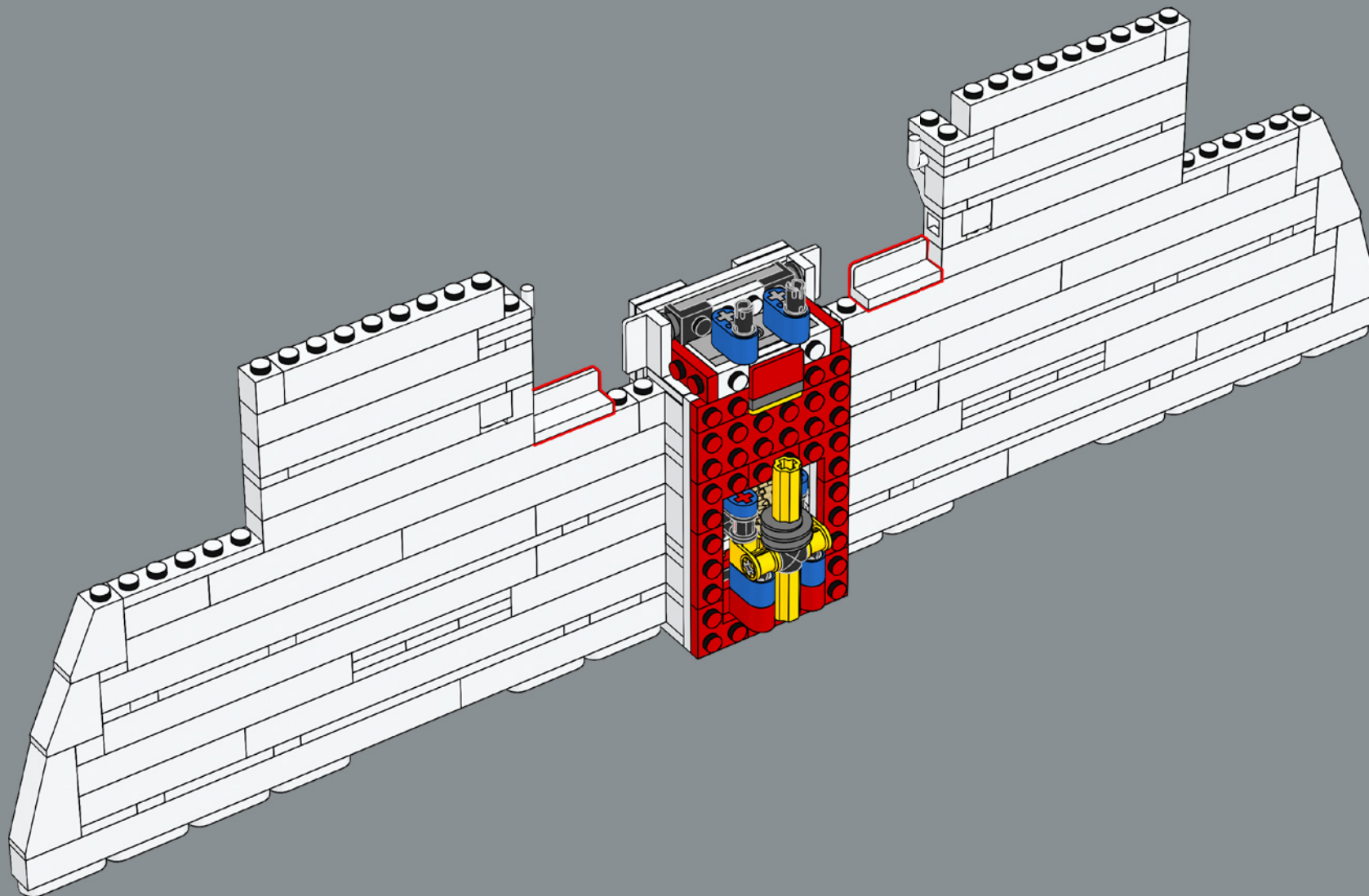

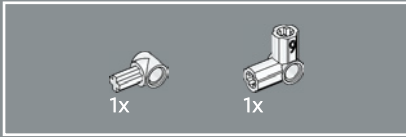
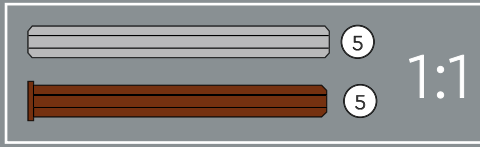
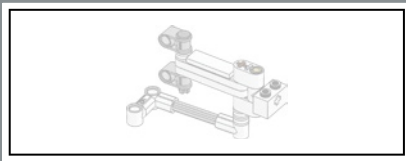

54

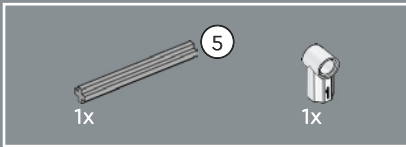
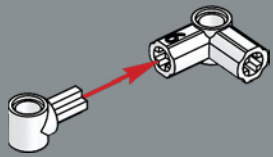

55

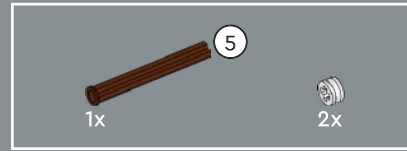
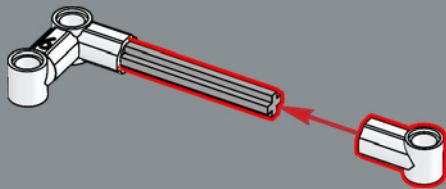

56

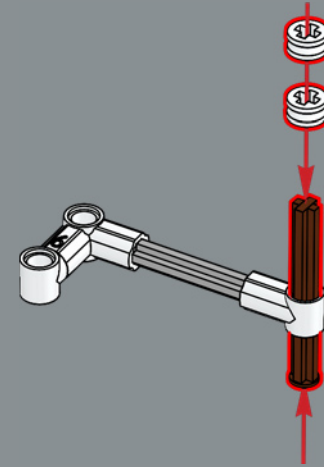

57

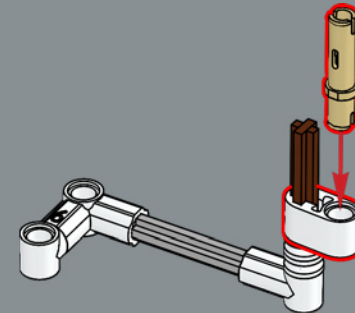

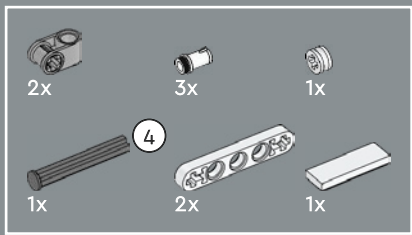

58

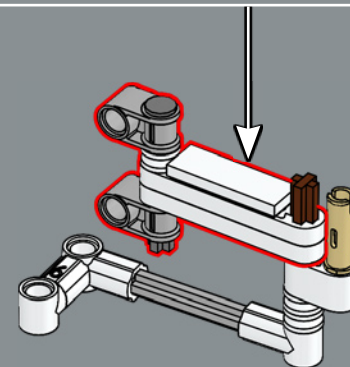
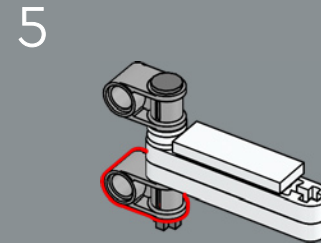
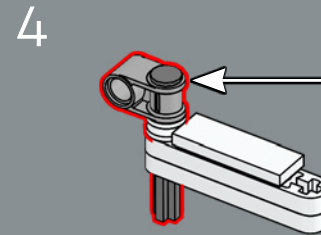
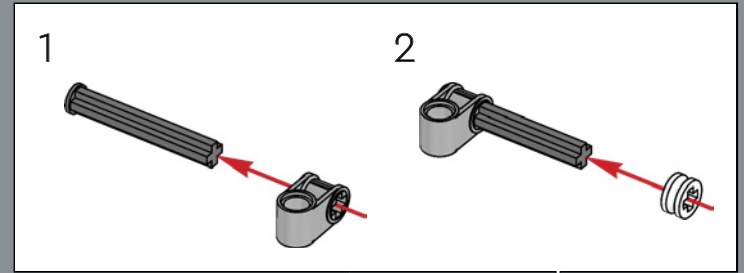
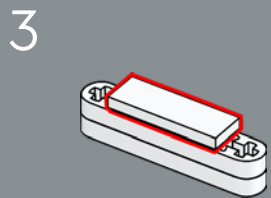
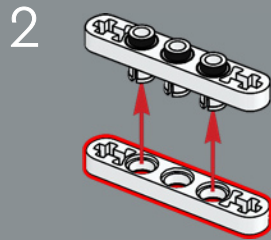
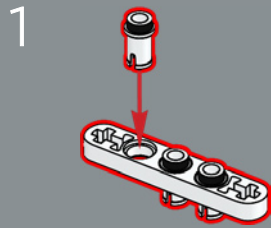

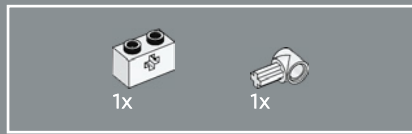

59

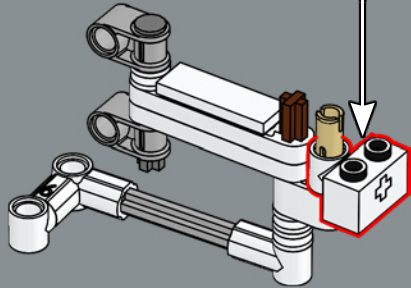
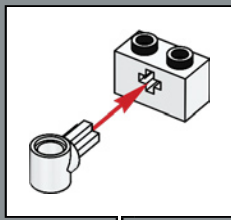

60

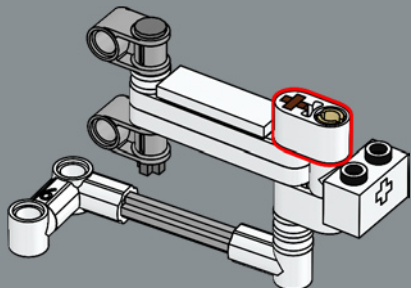

61

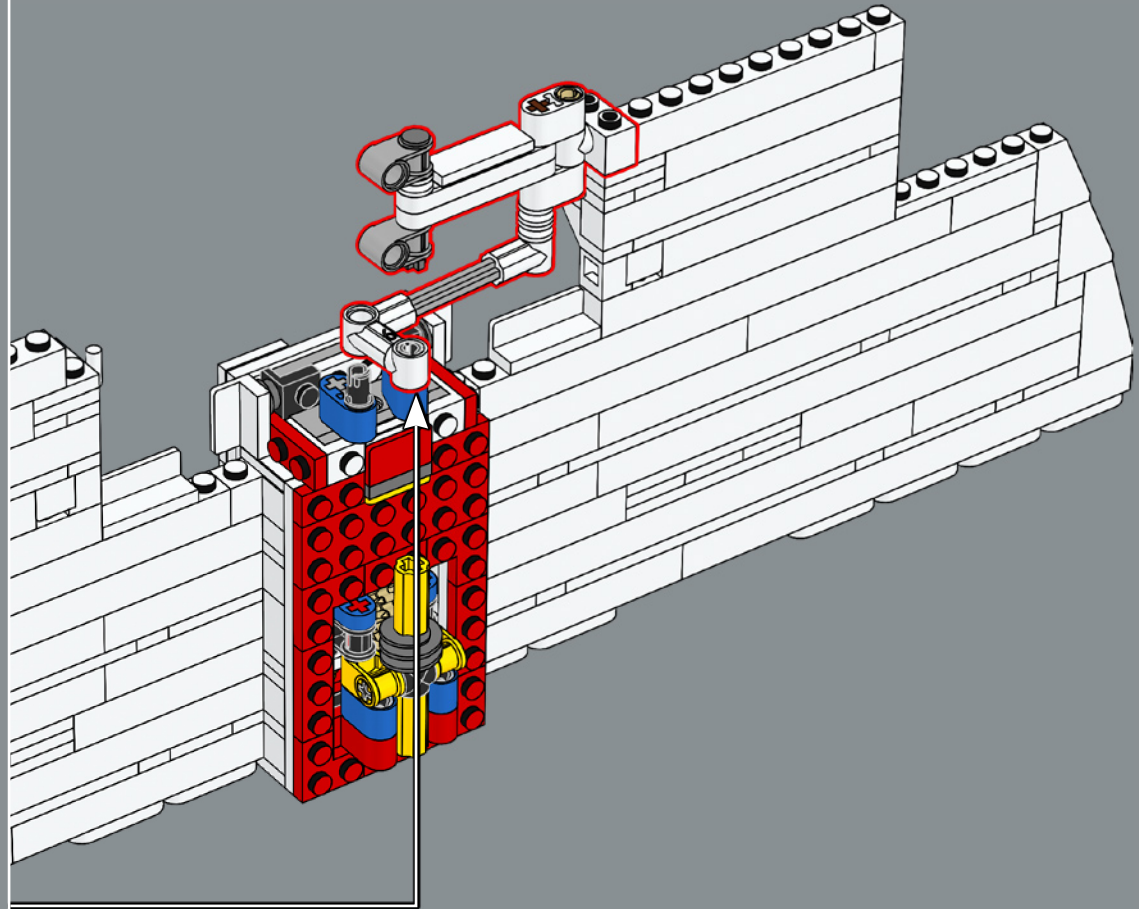

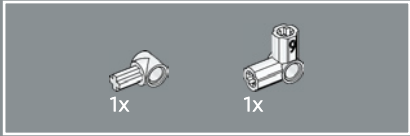
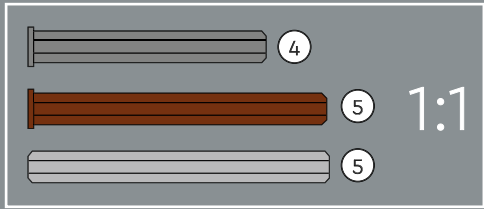
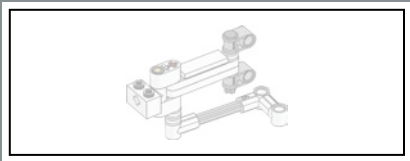

62

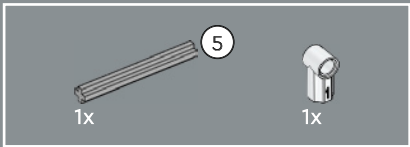
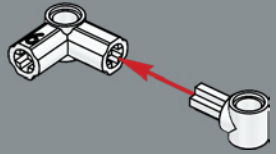

63

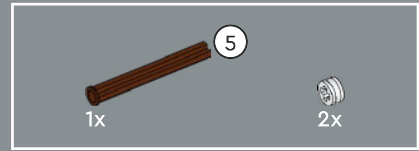
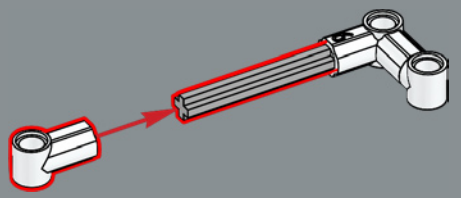

64

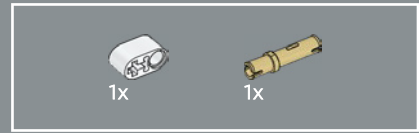
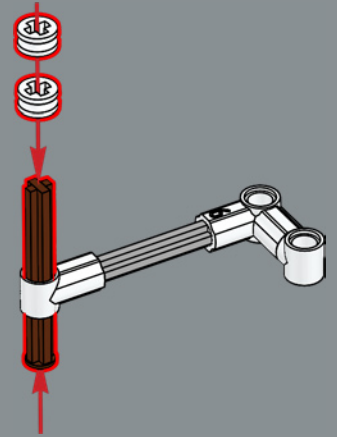

65

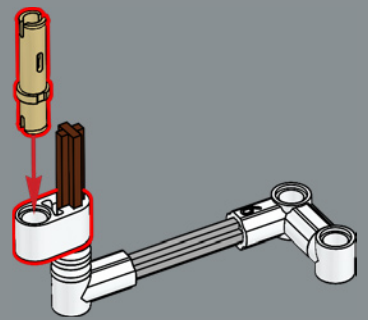

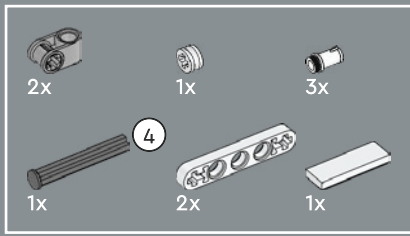

66

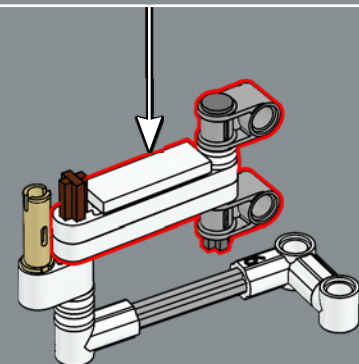
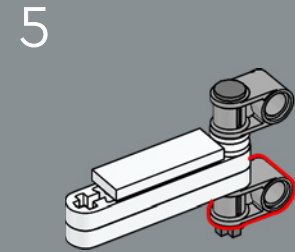
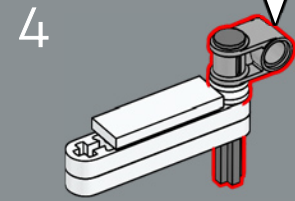
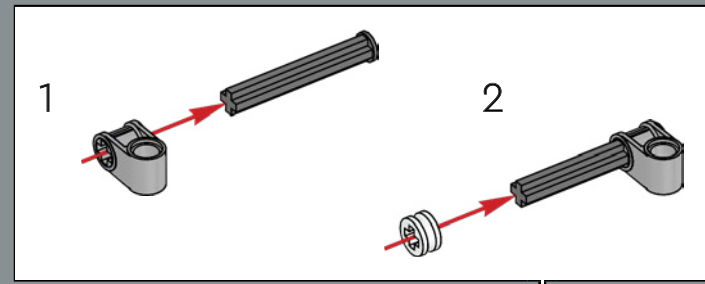
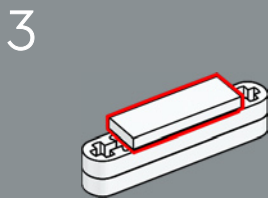
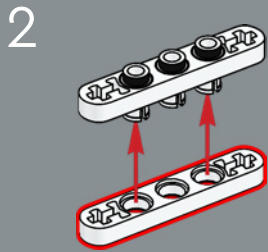
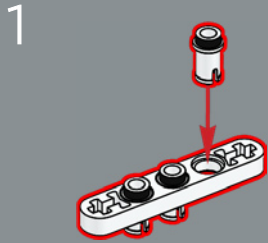

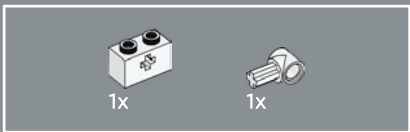

67

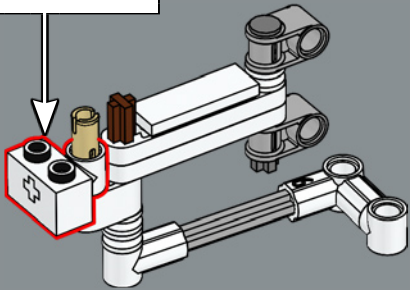
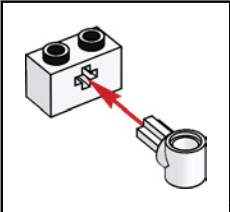

68

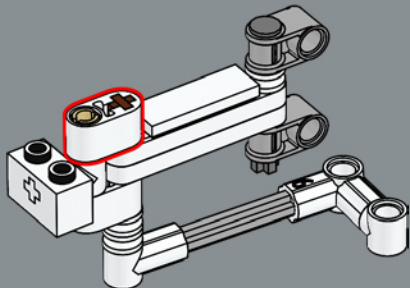

69

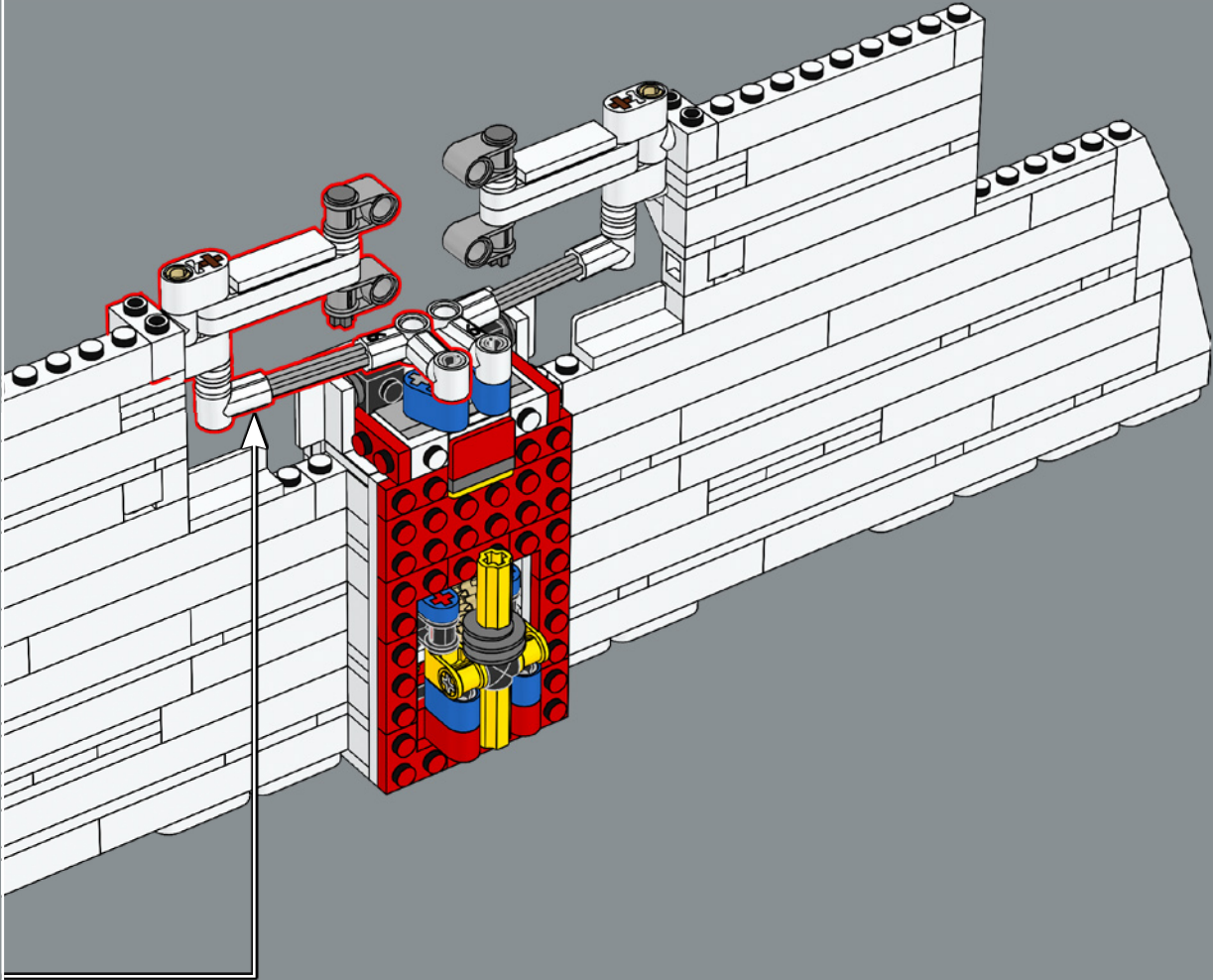



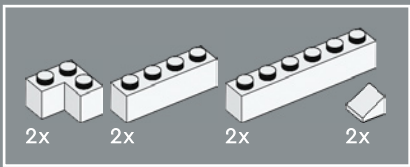

70

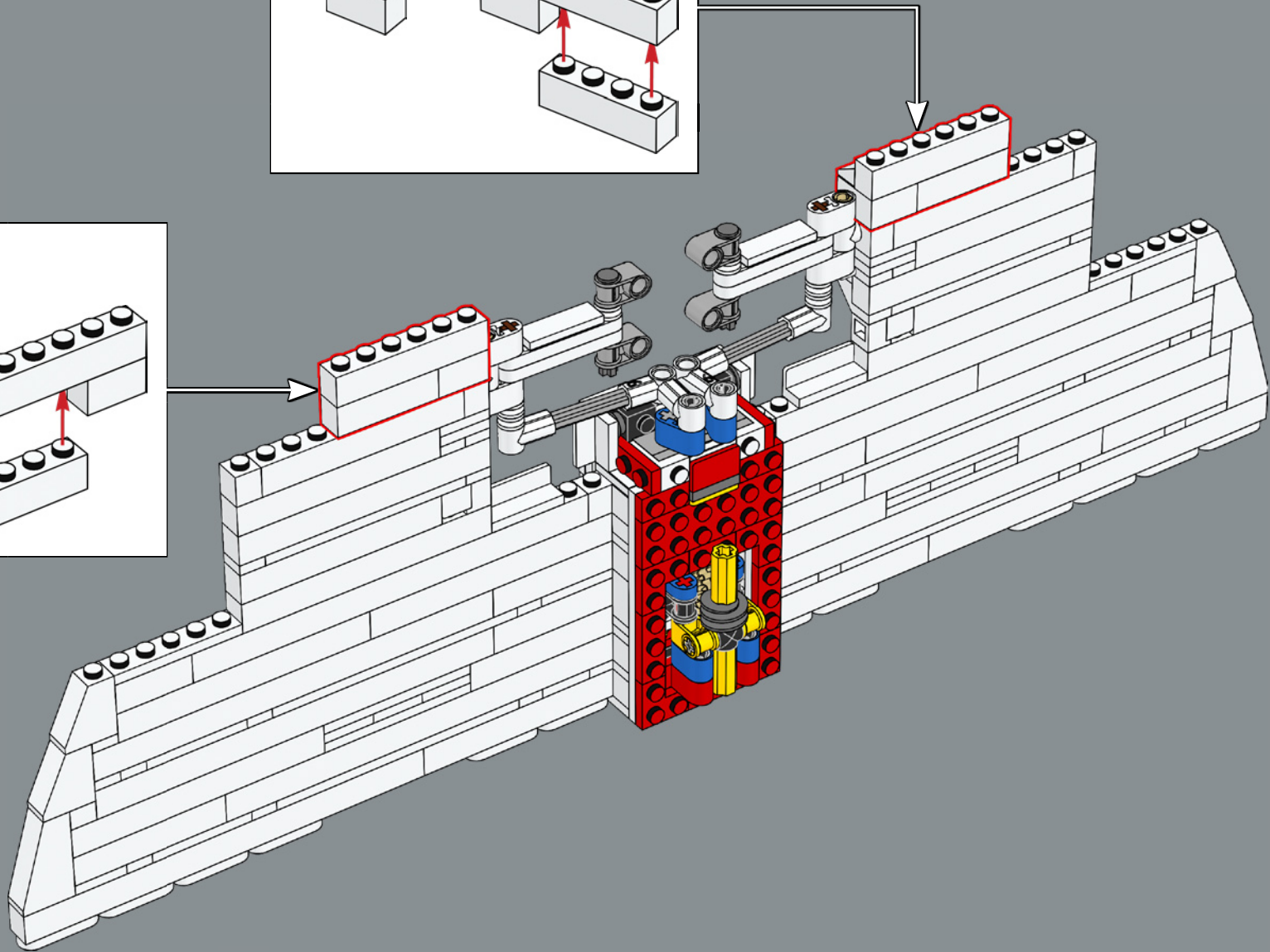
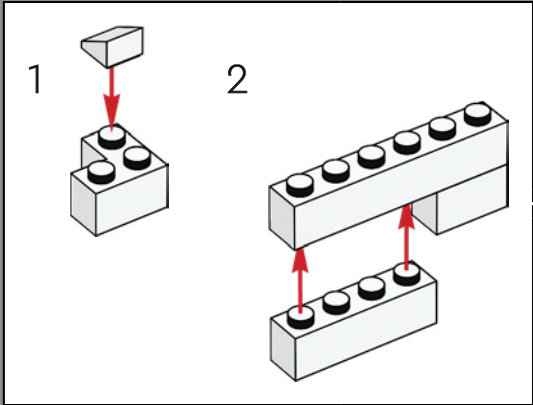
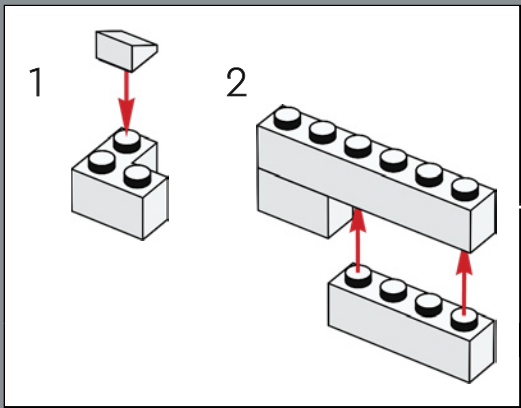

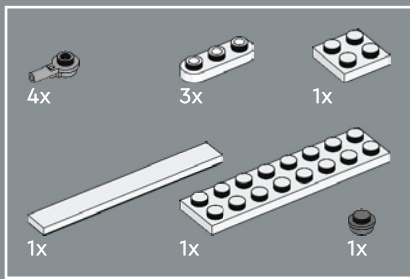

71

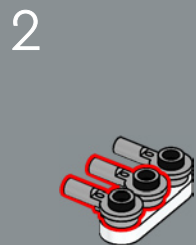
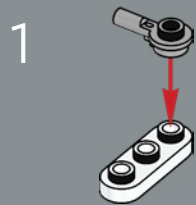

3

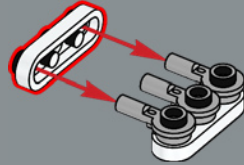

4

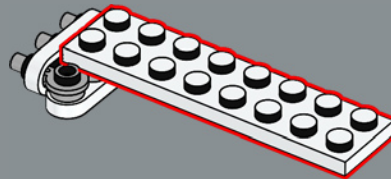

5

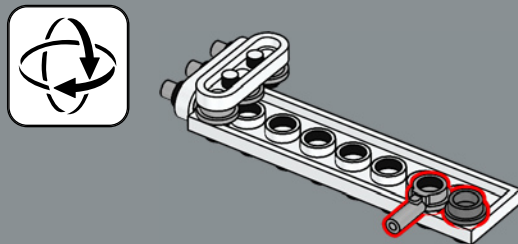

6

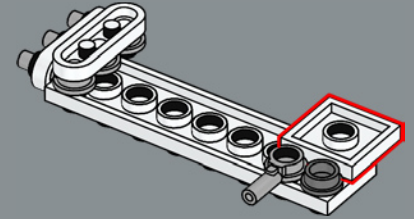

7

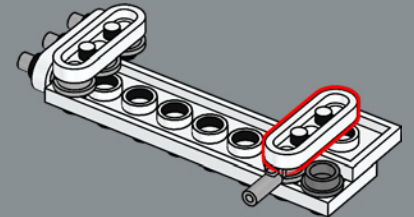

8

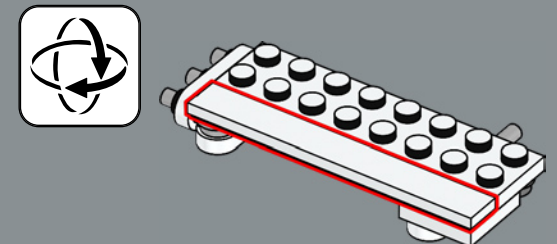

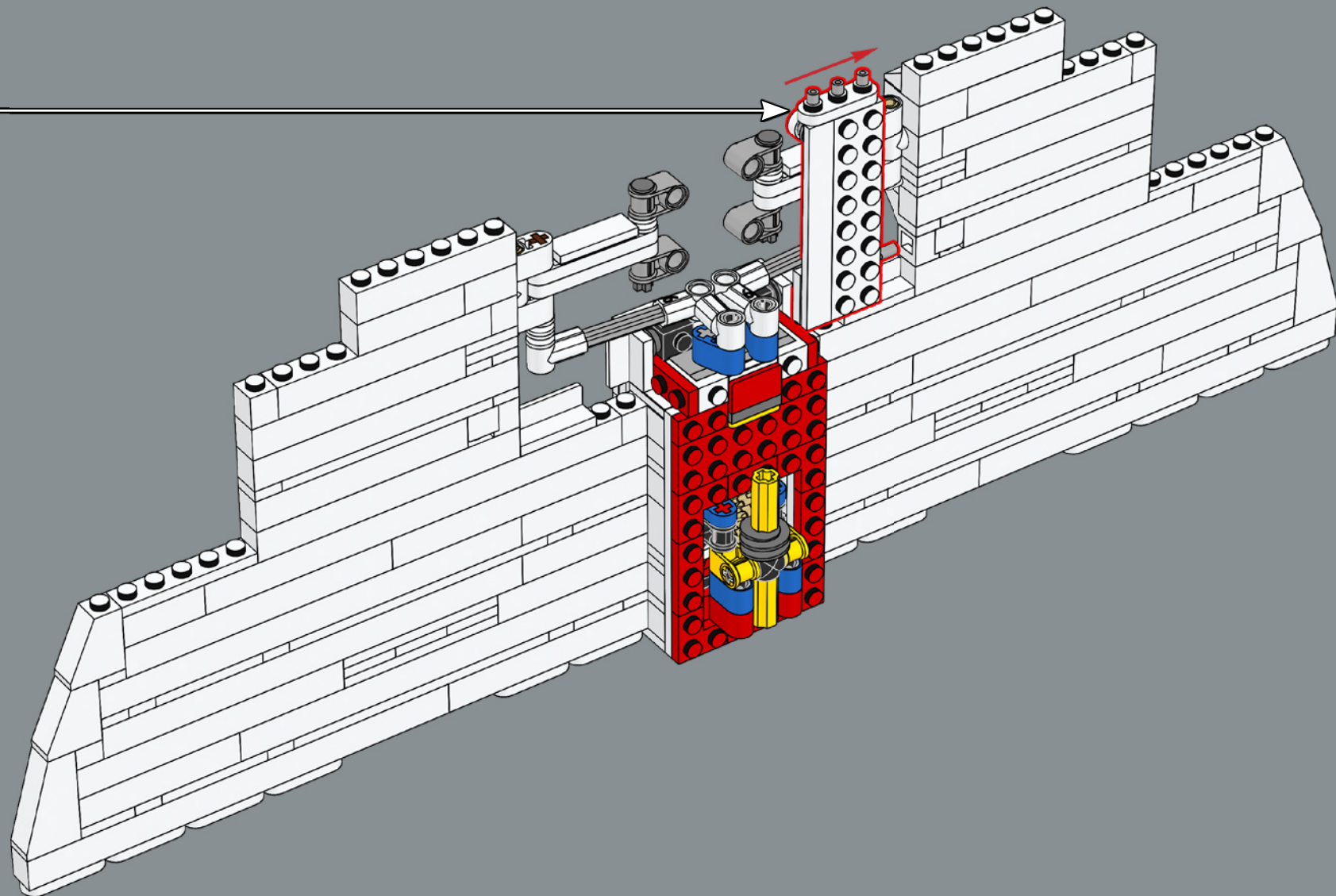

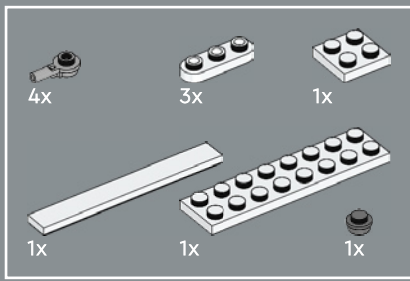

72

1

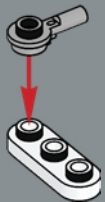

2

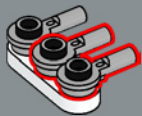

3

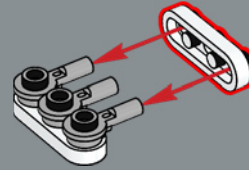

4

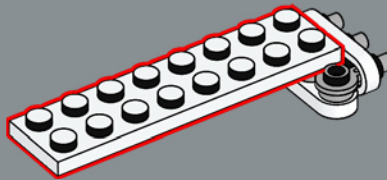

5

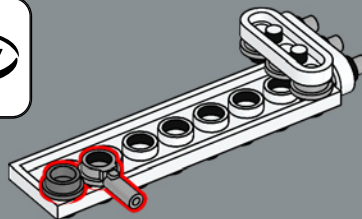

6

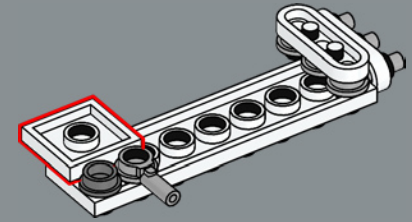

7

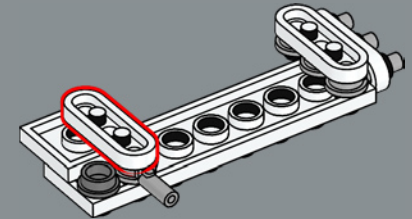

8

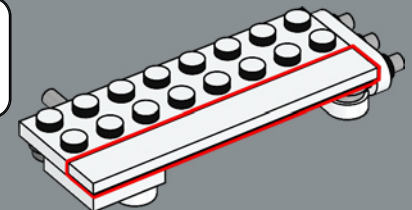



飞机需要用到定制的白色油漆，以散发由超音速飞行产生的热量。

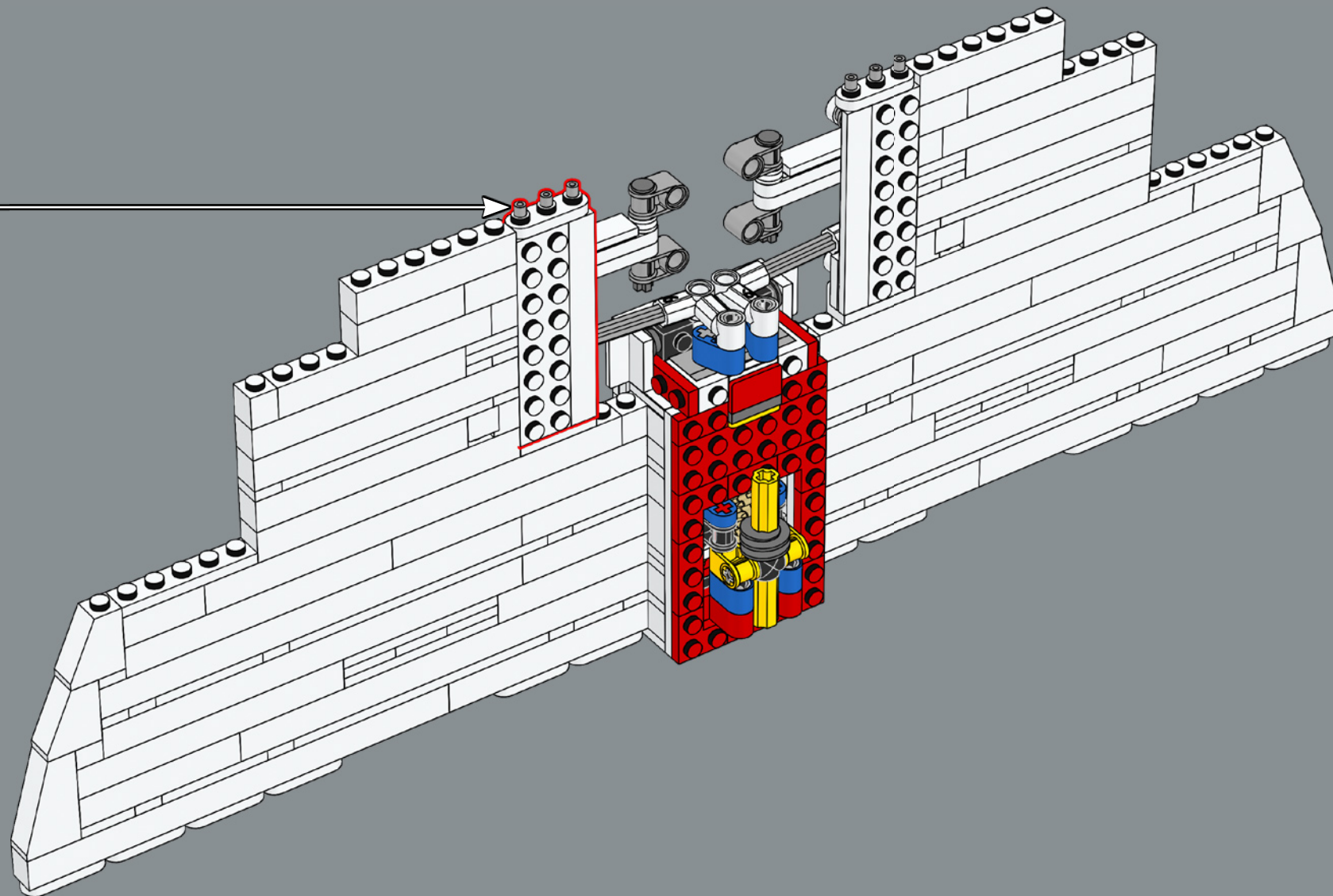



73

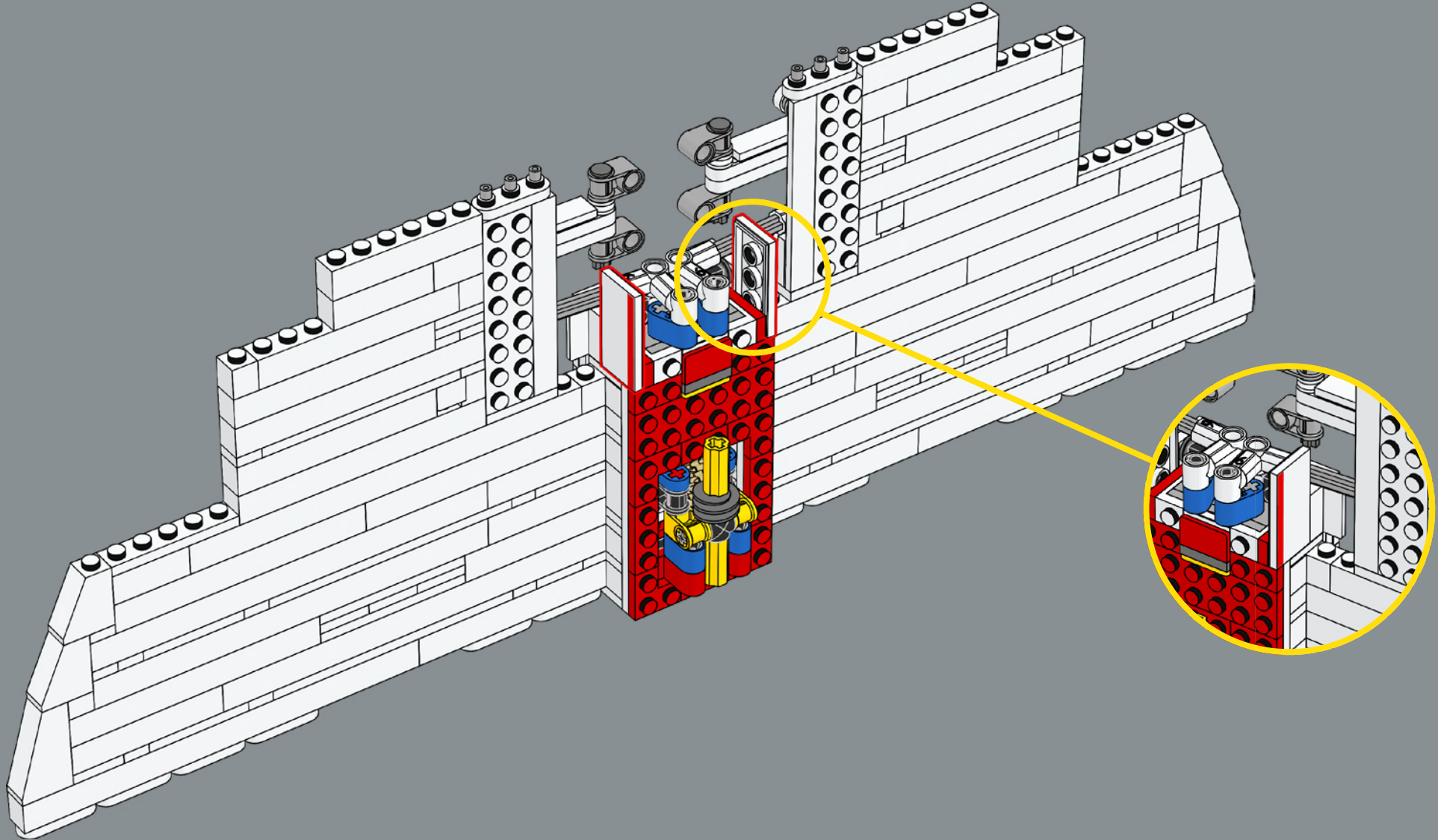

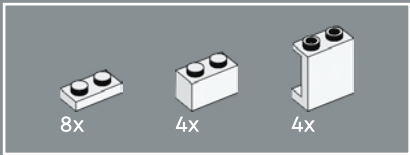

74

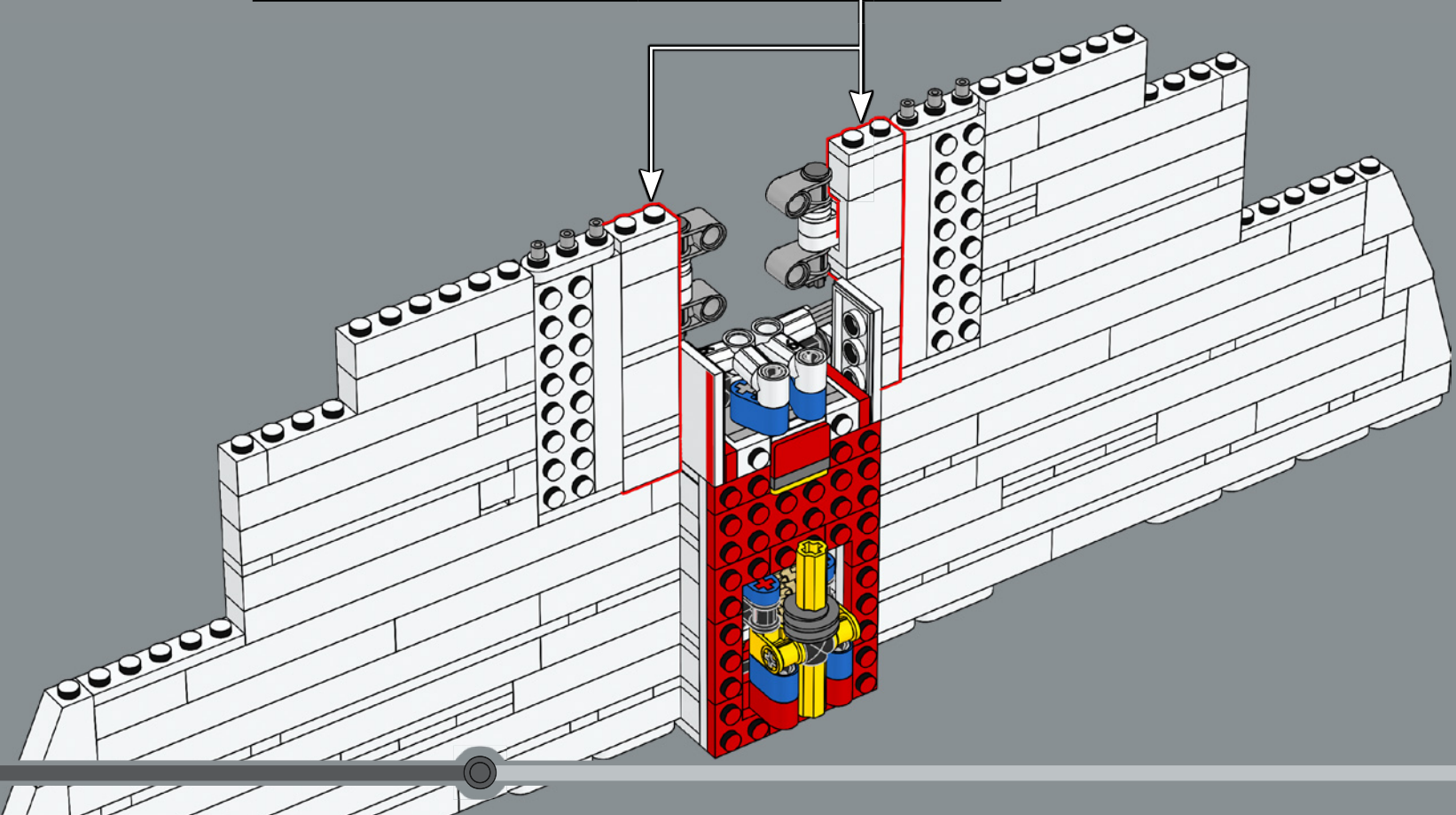
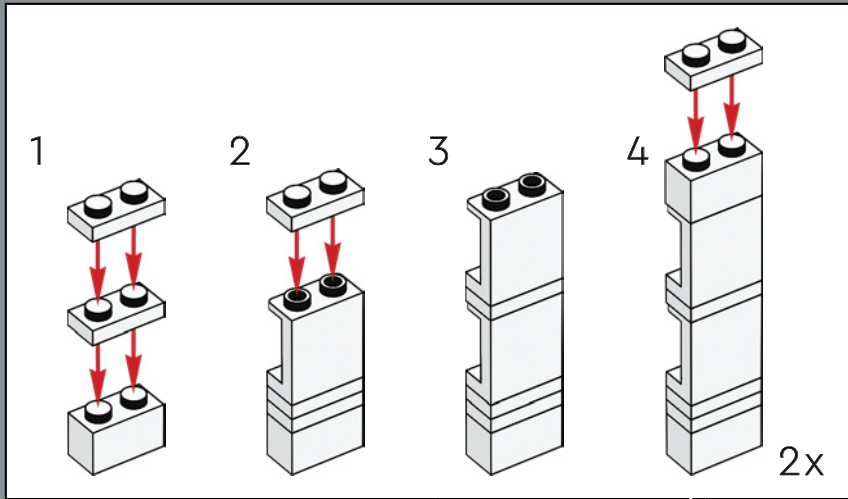

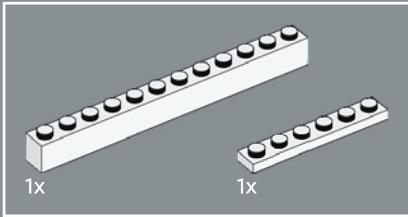
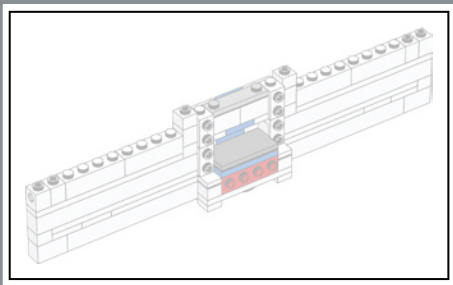

75

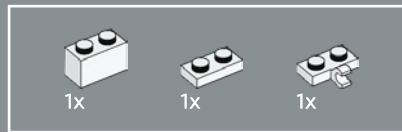
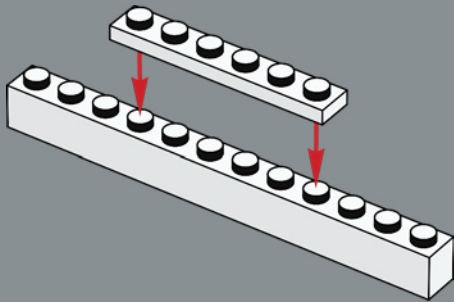

76

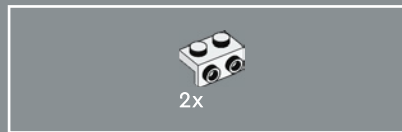
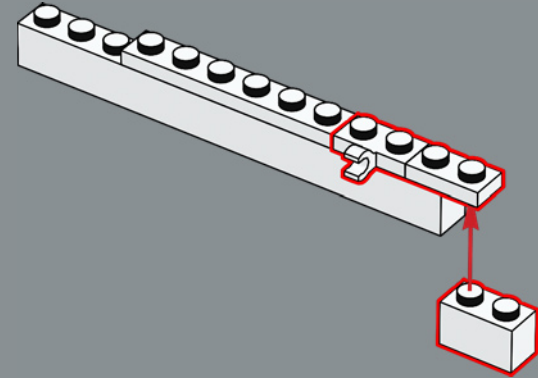

77

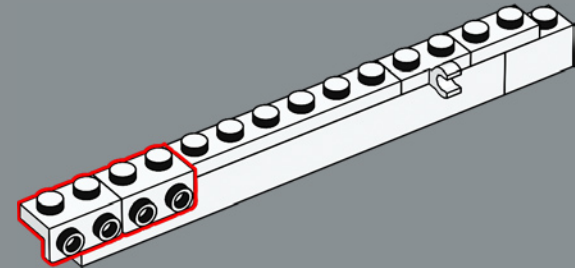

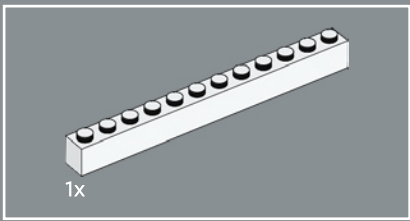

78

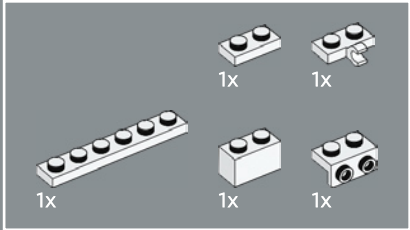
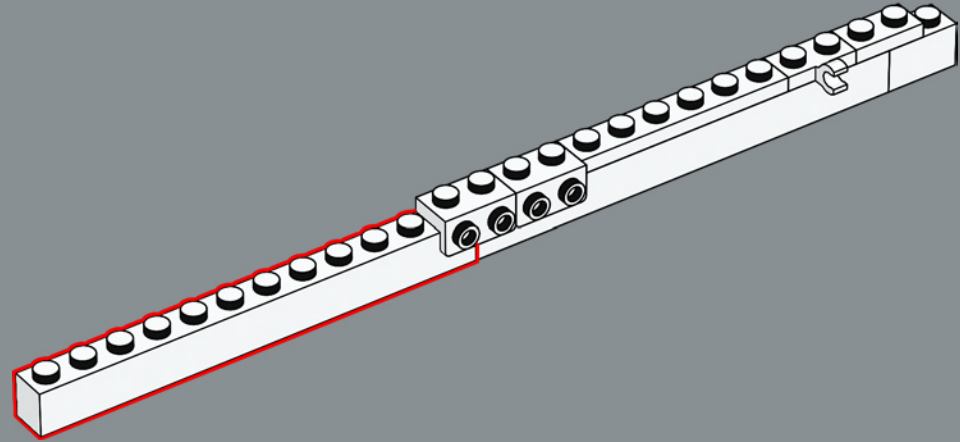

79

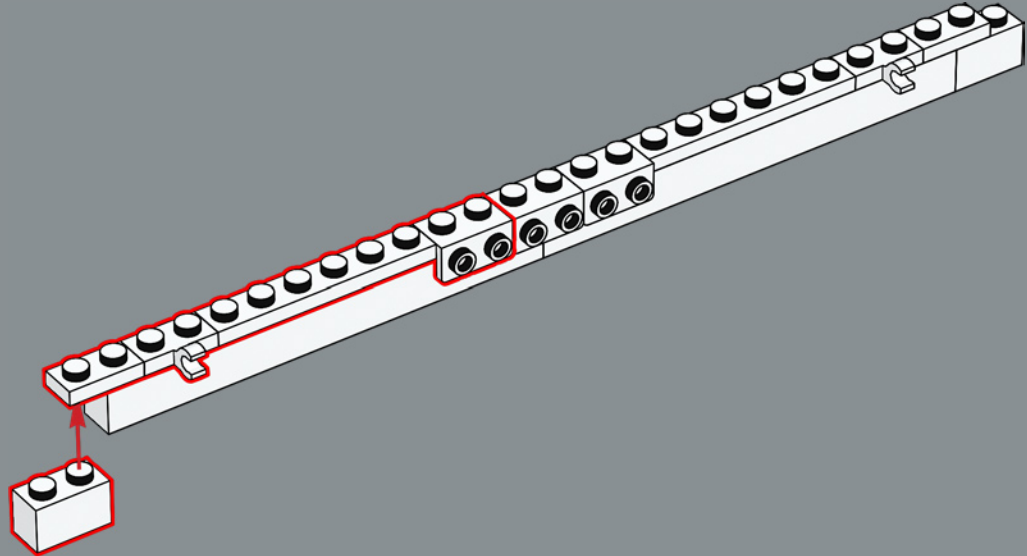

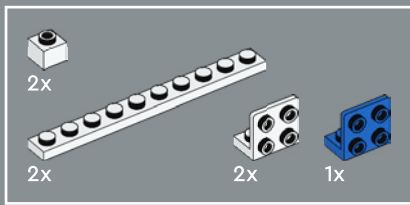

80

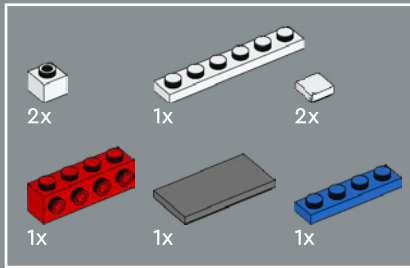
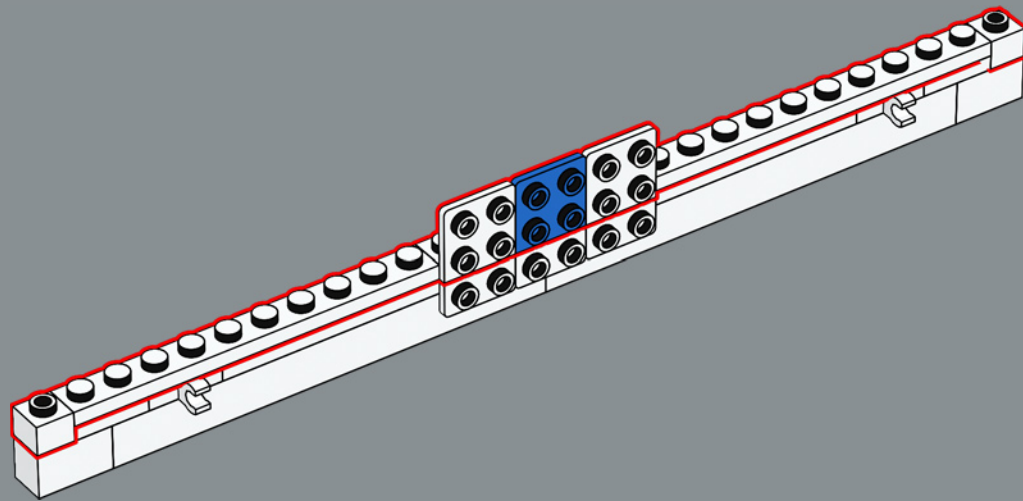

81

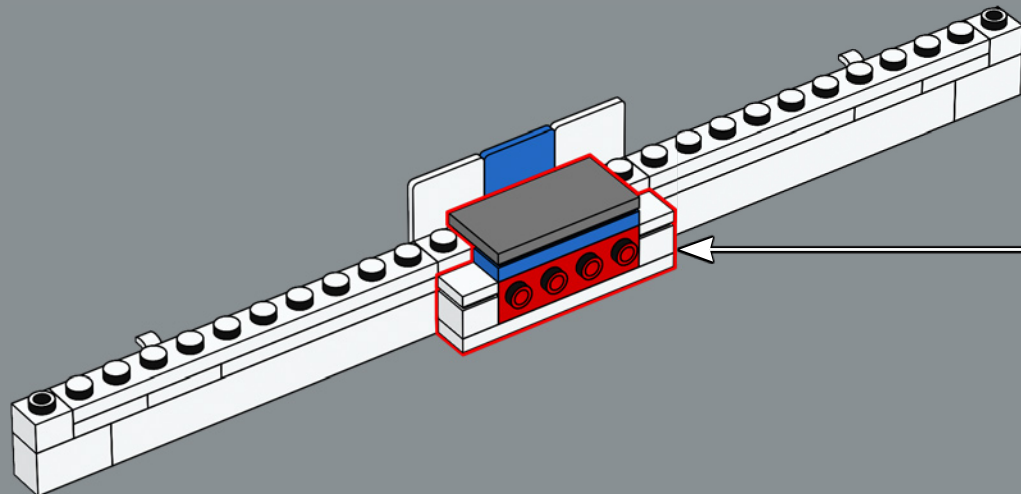
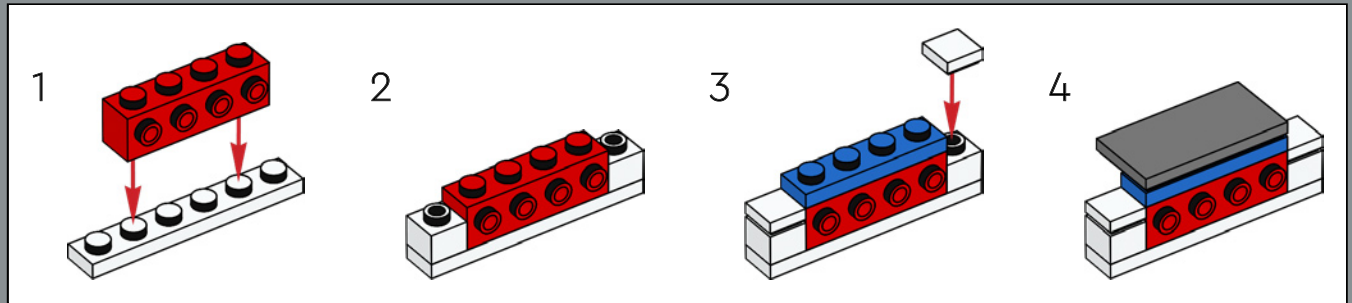

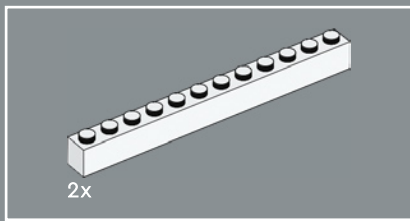

82

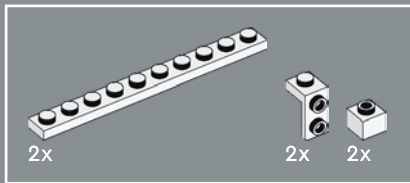
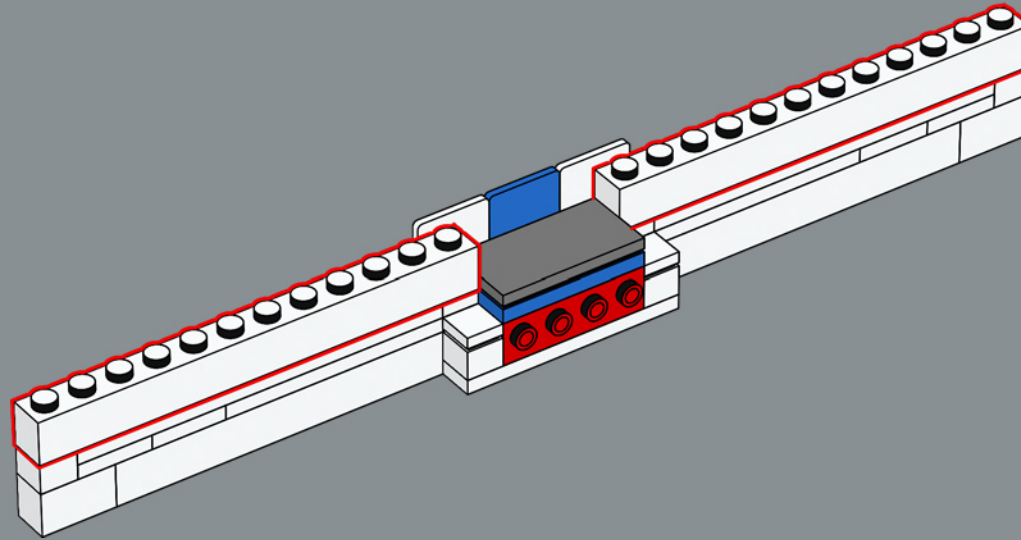

83

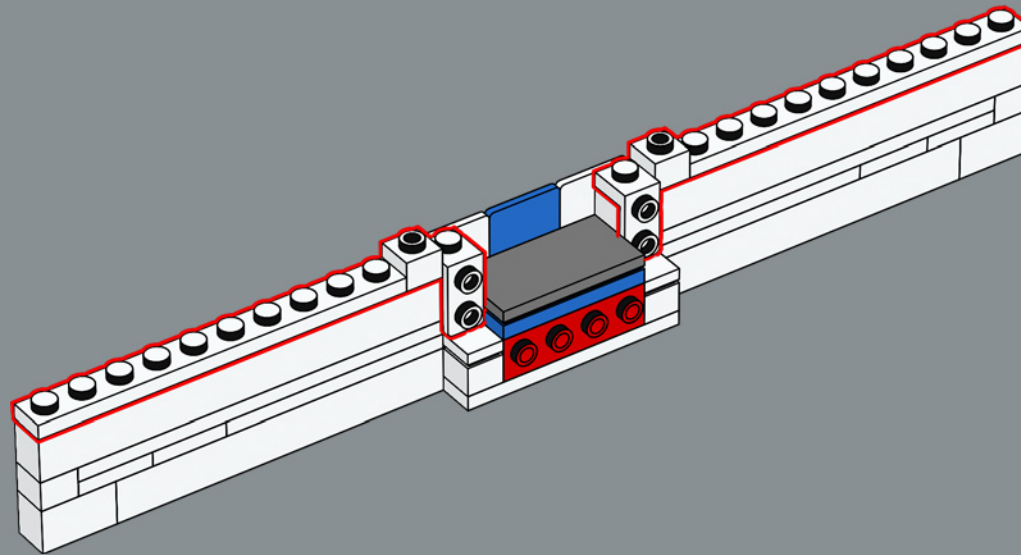

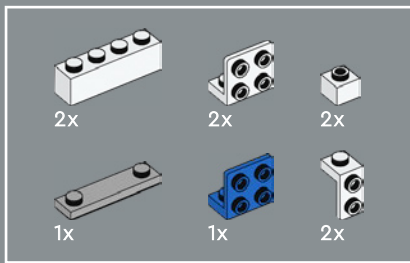

84

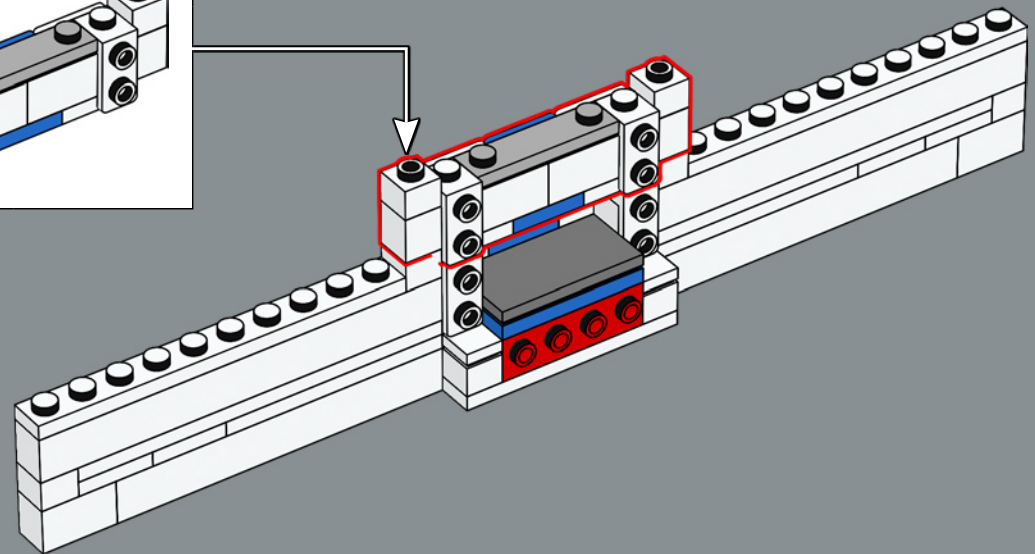
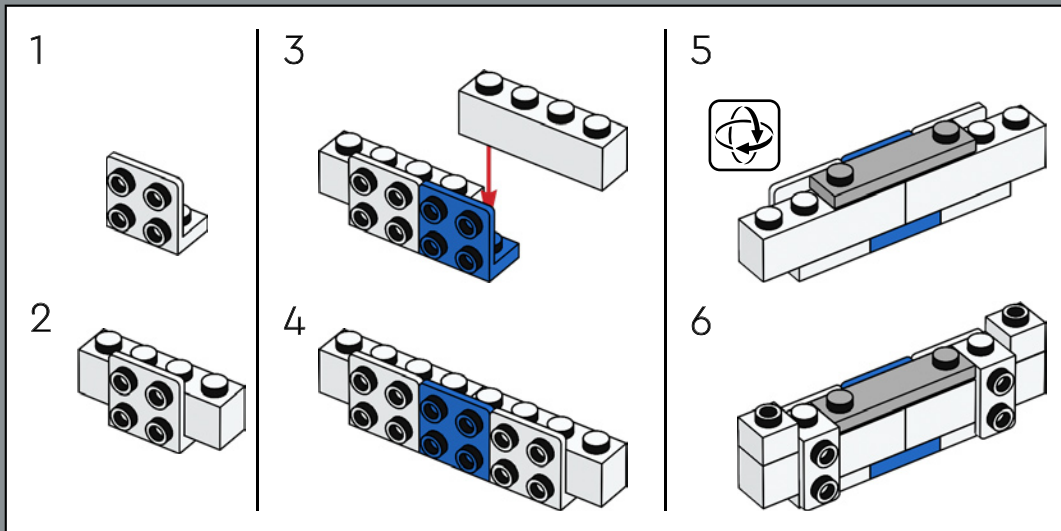

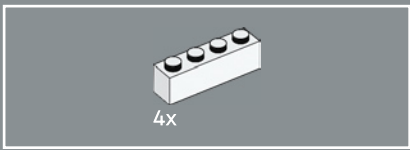

85

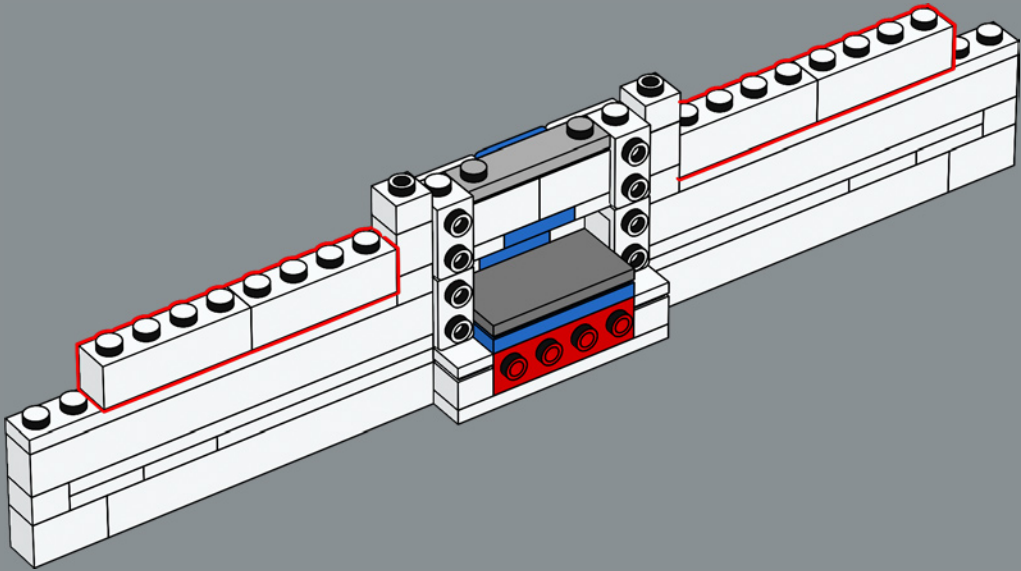

86

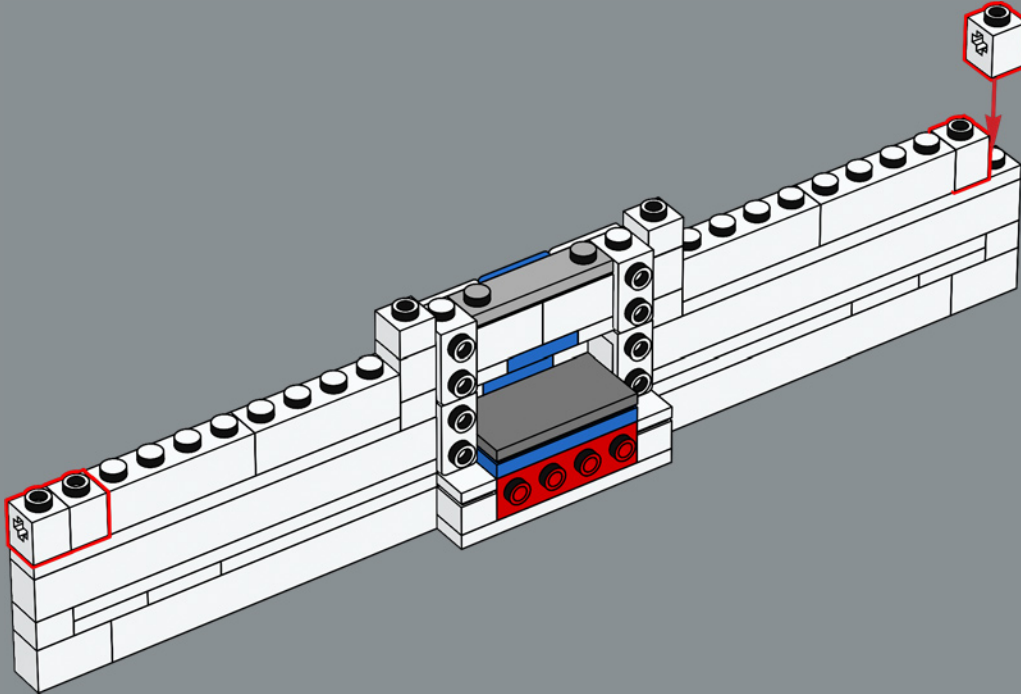

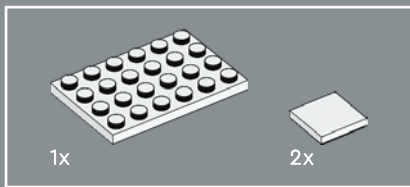

87

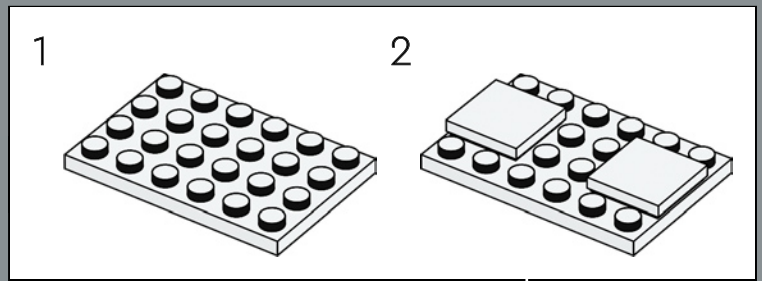
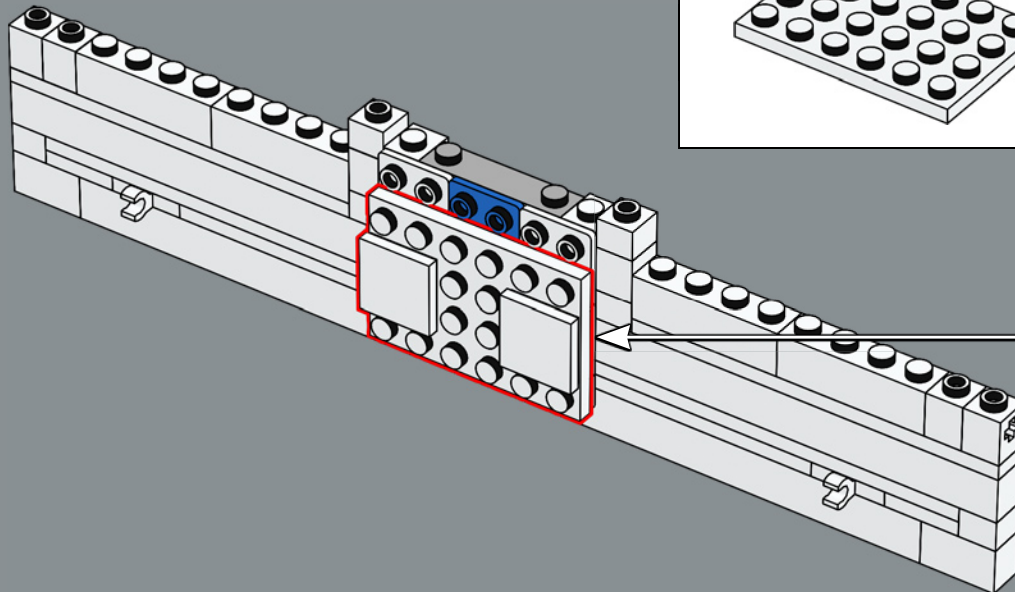

88

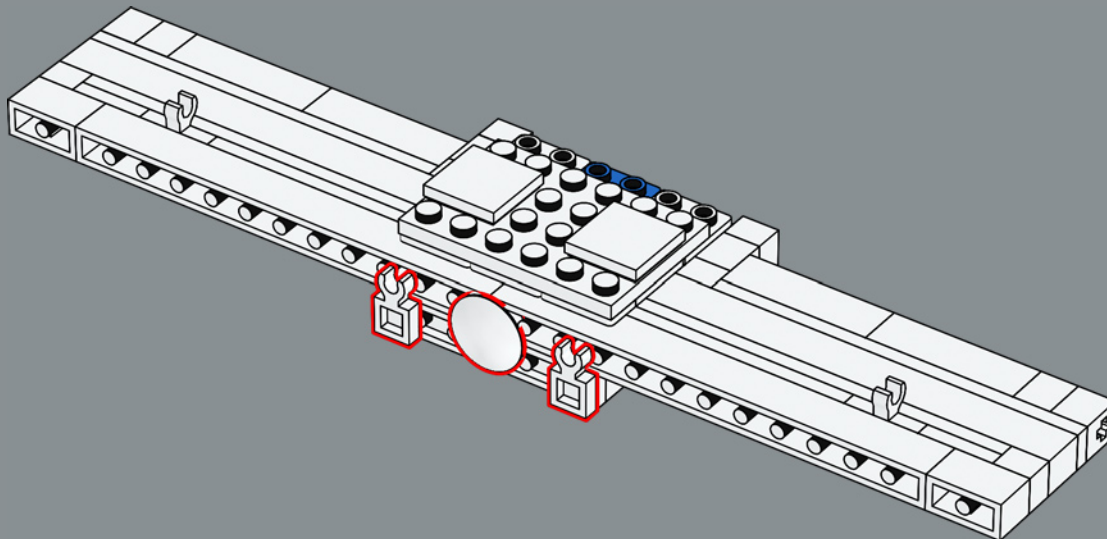

89

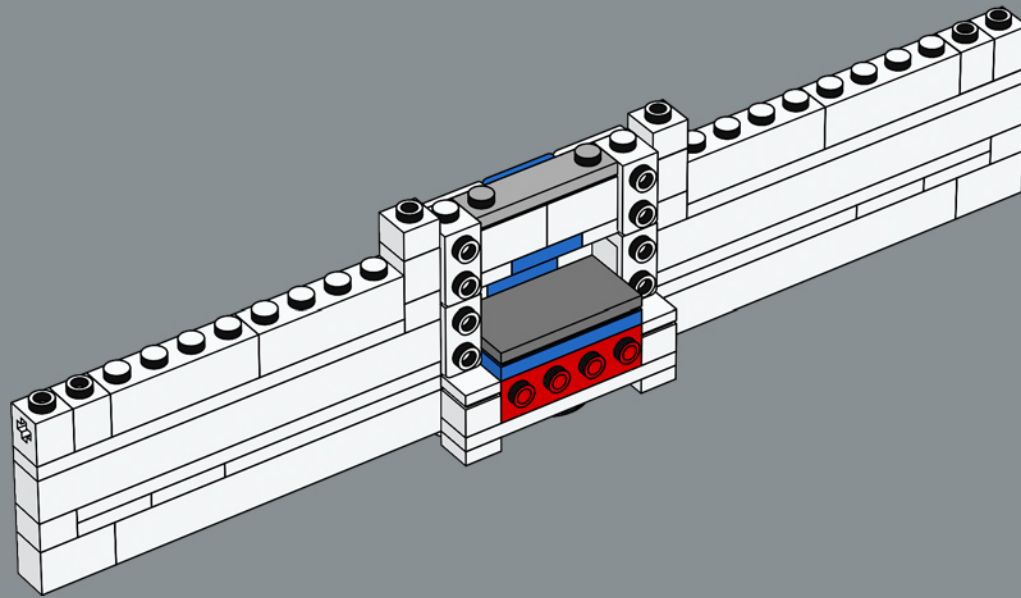

90

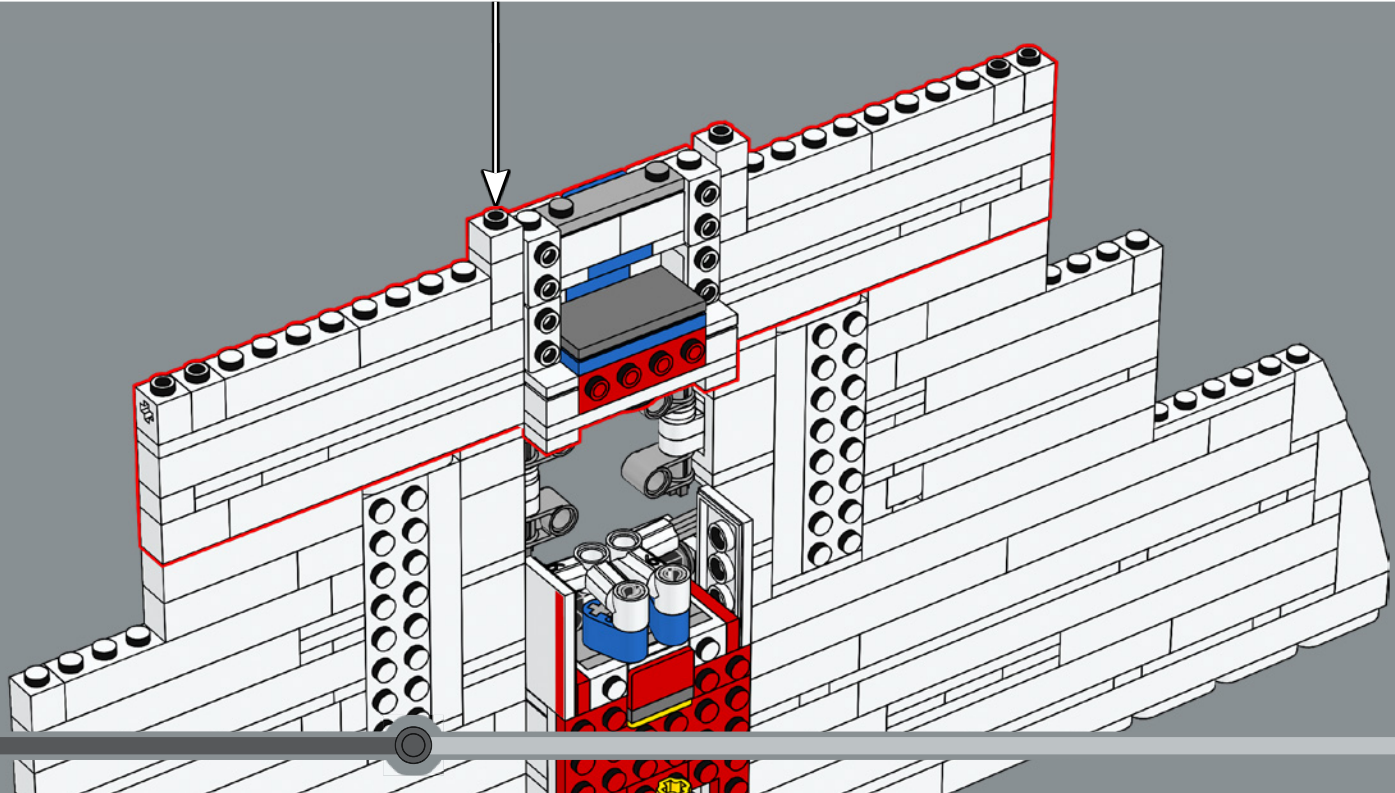



经典的协和式飞机轮廓源自一个非常现实的技术问题，即超音速机翼上阻力最小化与产生升力之间的平衡。解决方案：协和式飞机的 S 型前缘三角翼是对三角翼设计的改进，以提高低速飞行的效率。

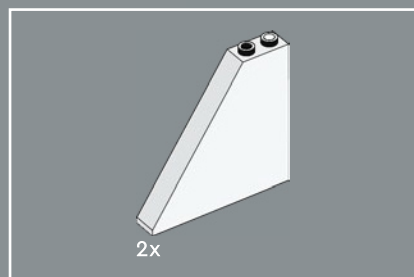

91

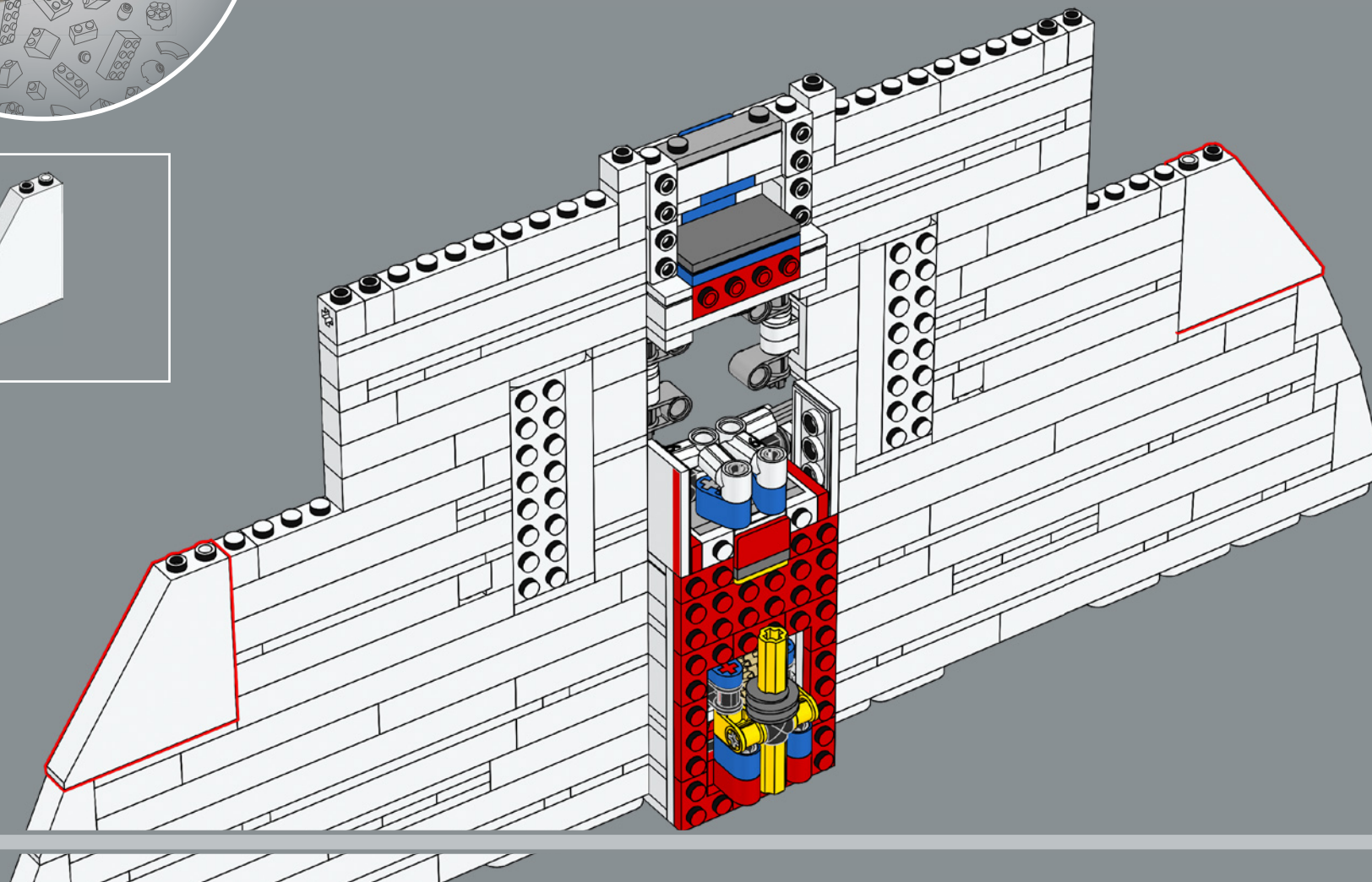

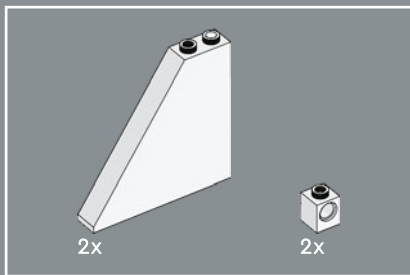

92

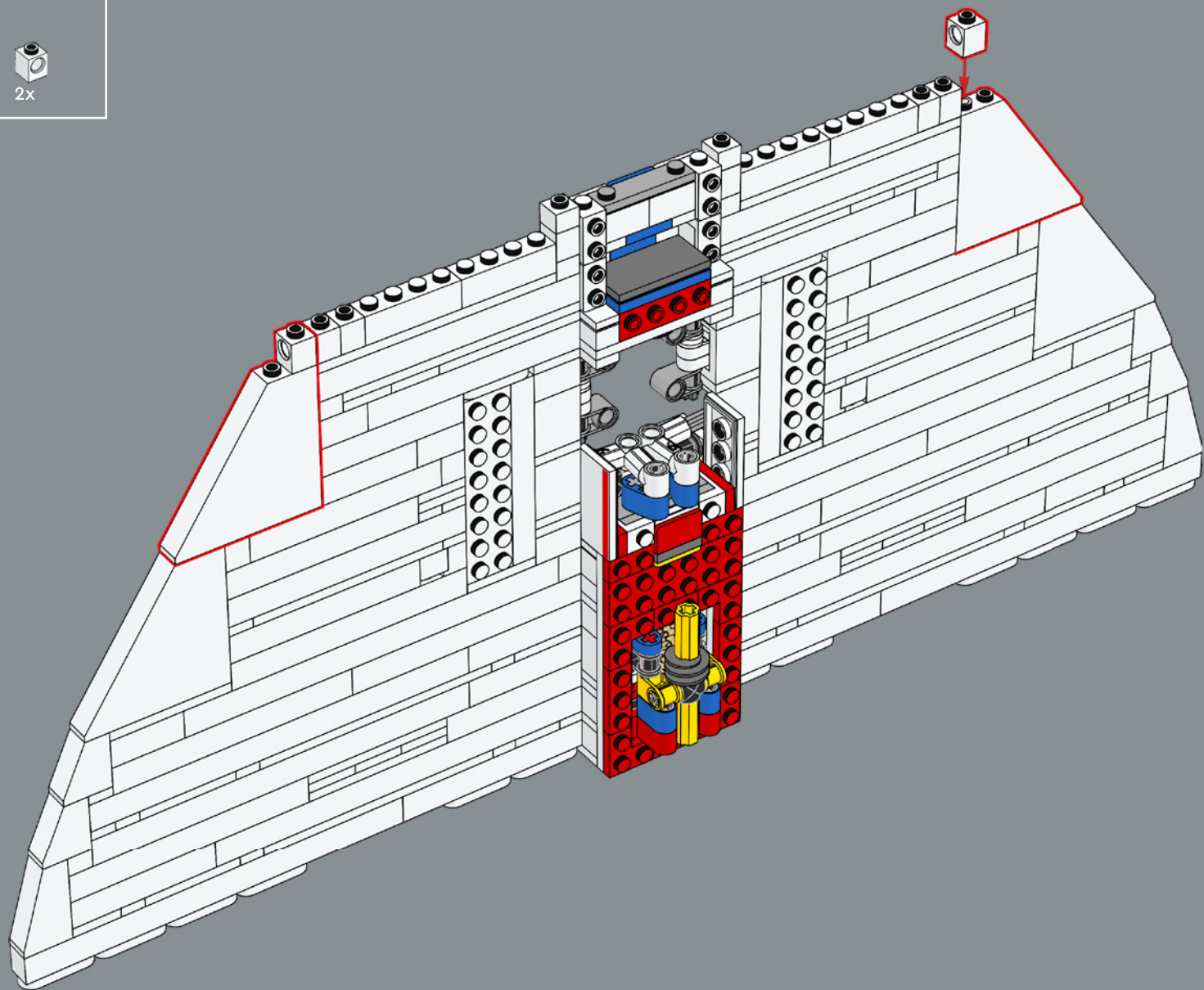

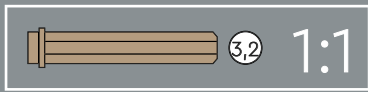
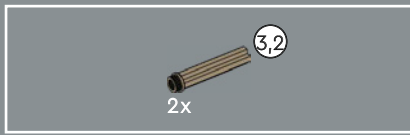

93

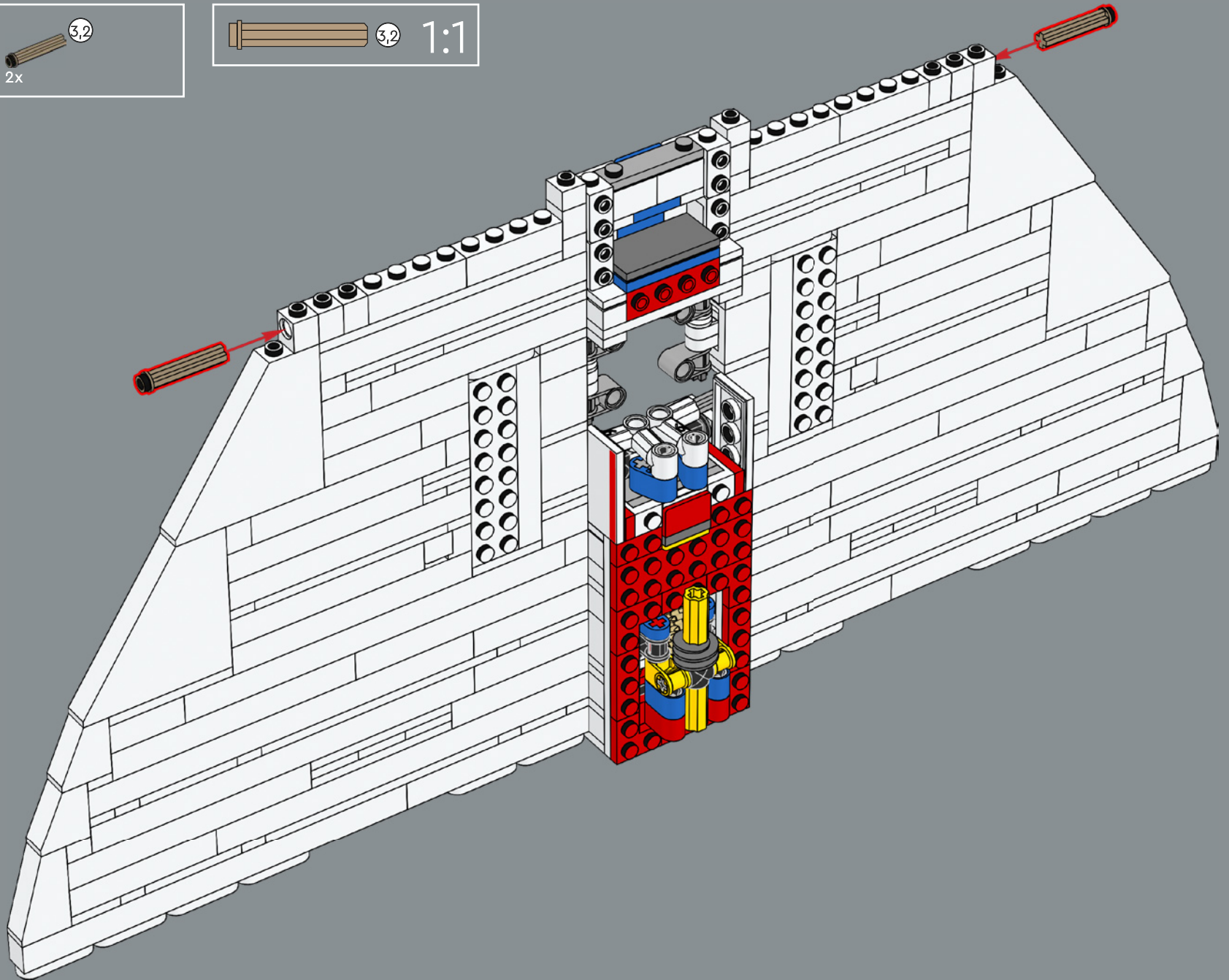

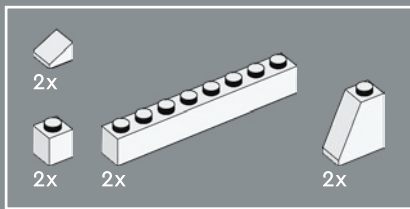

94

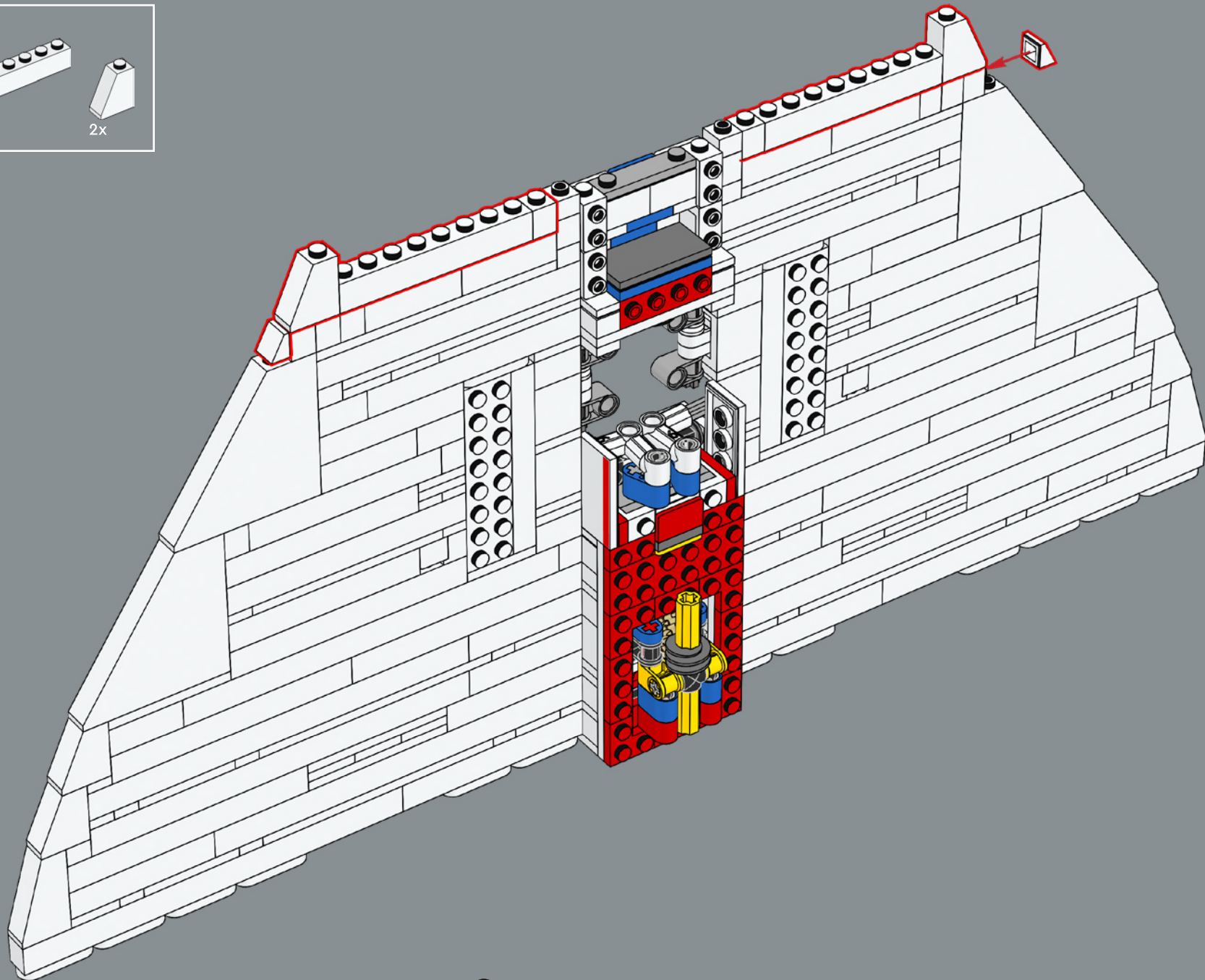

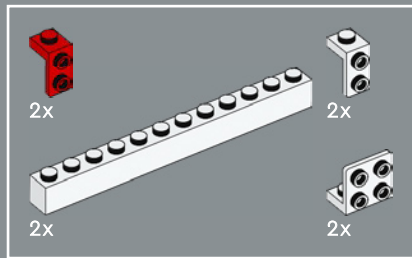

95

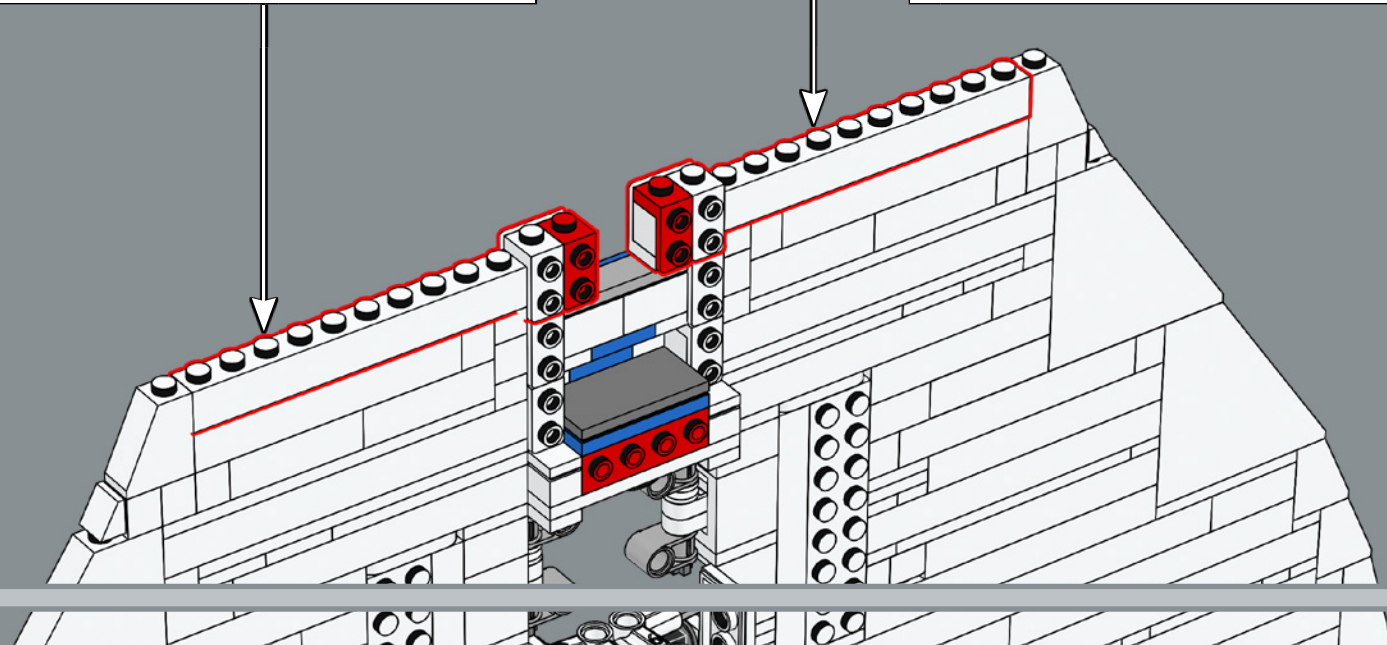
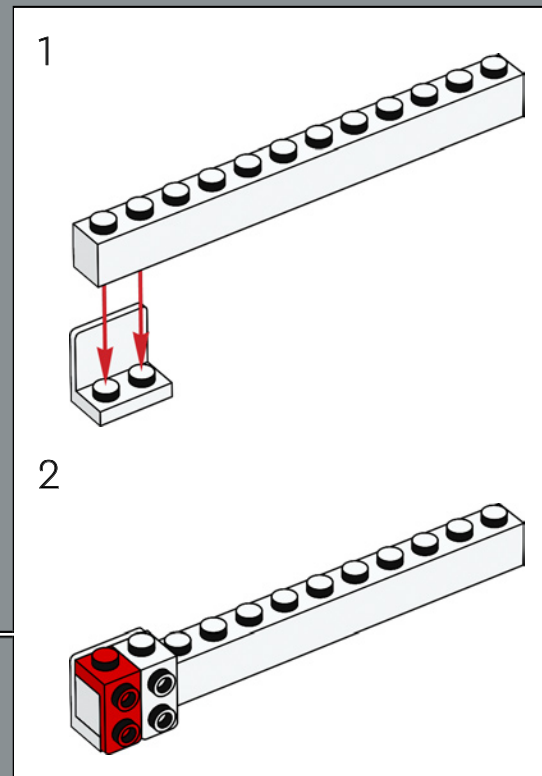
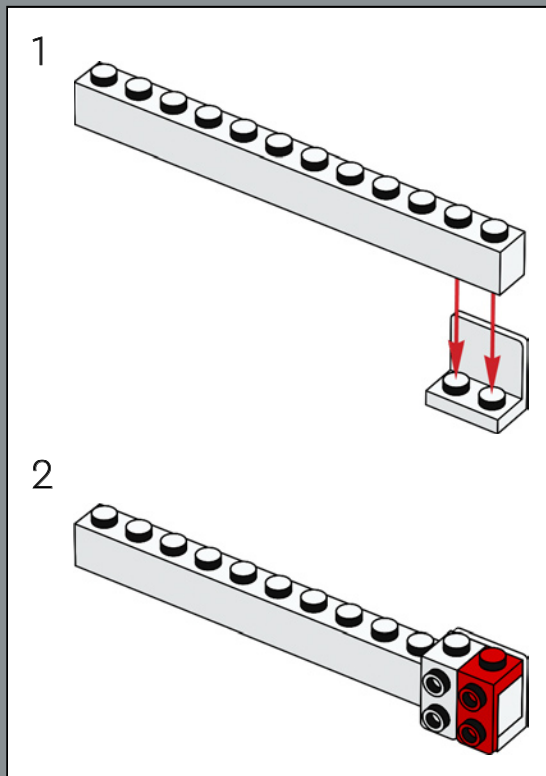

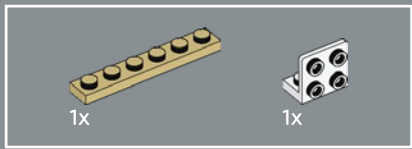

96

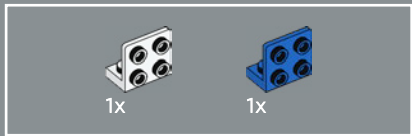
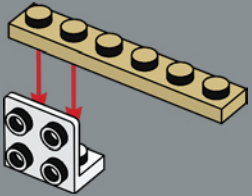

97

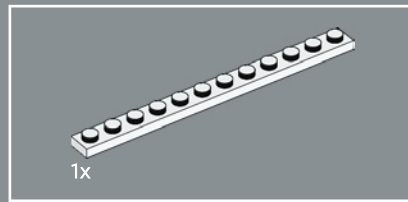
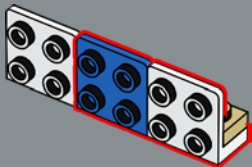

98

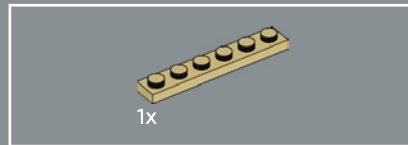
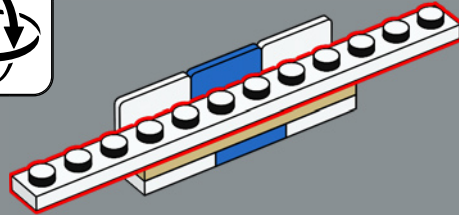

99

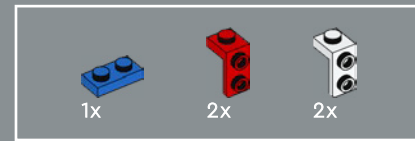
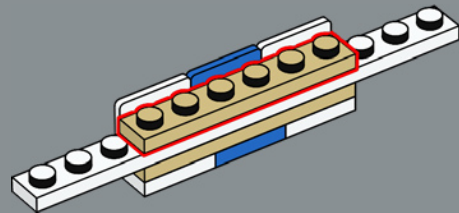

100

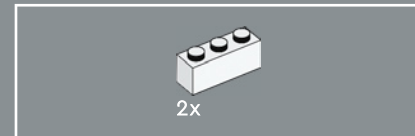
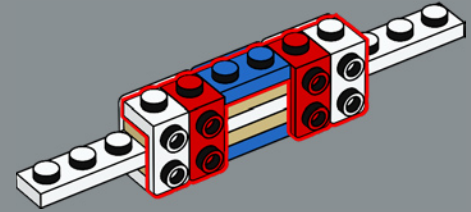

101

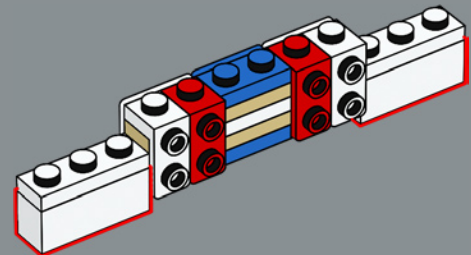

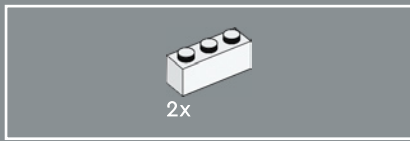

102

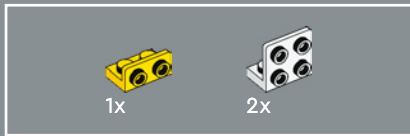
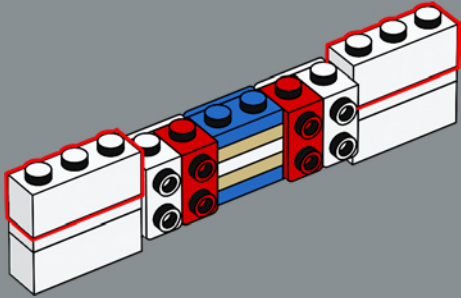

103

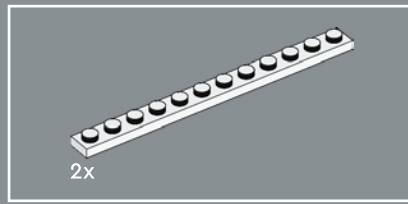
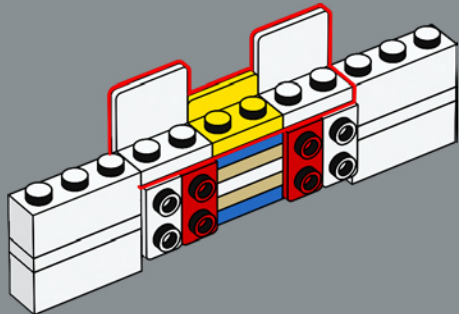

104

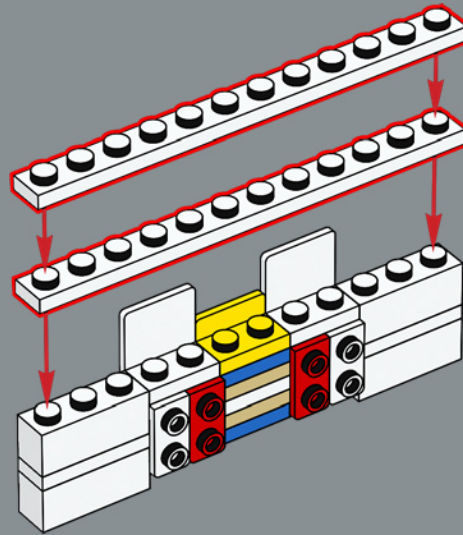

105

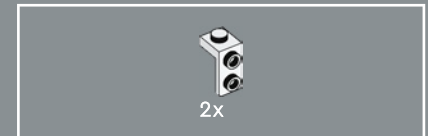
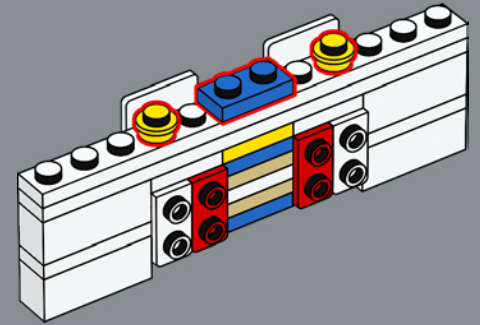

106

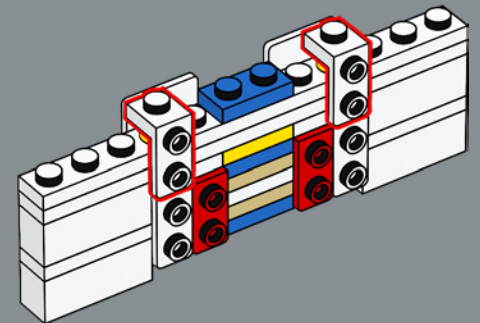

107

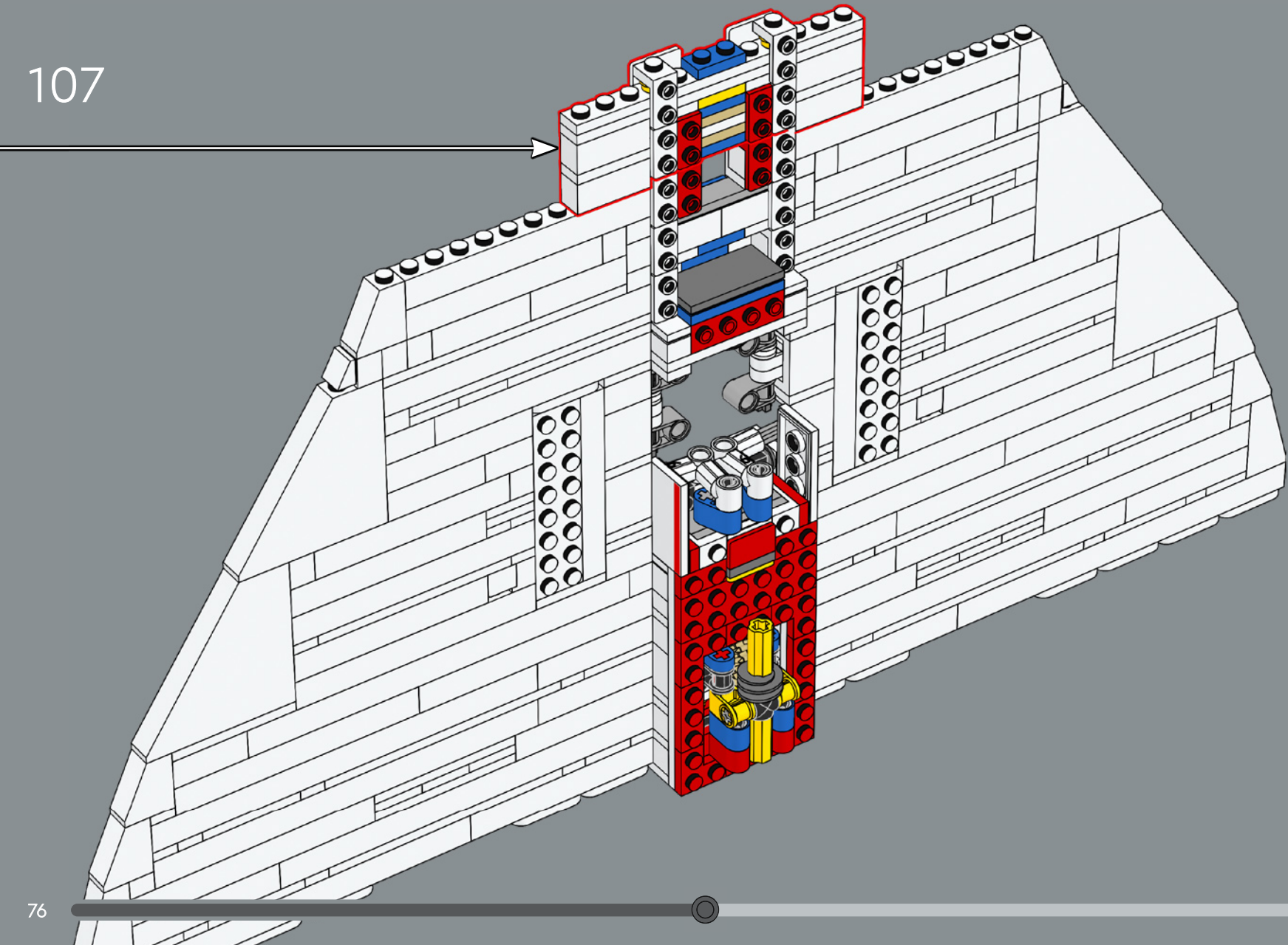

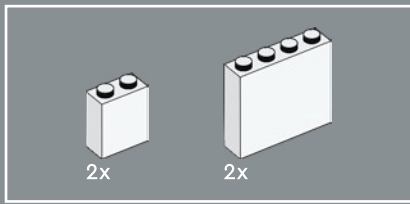

108

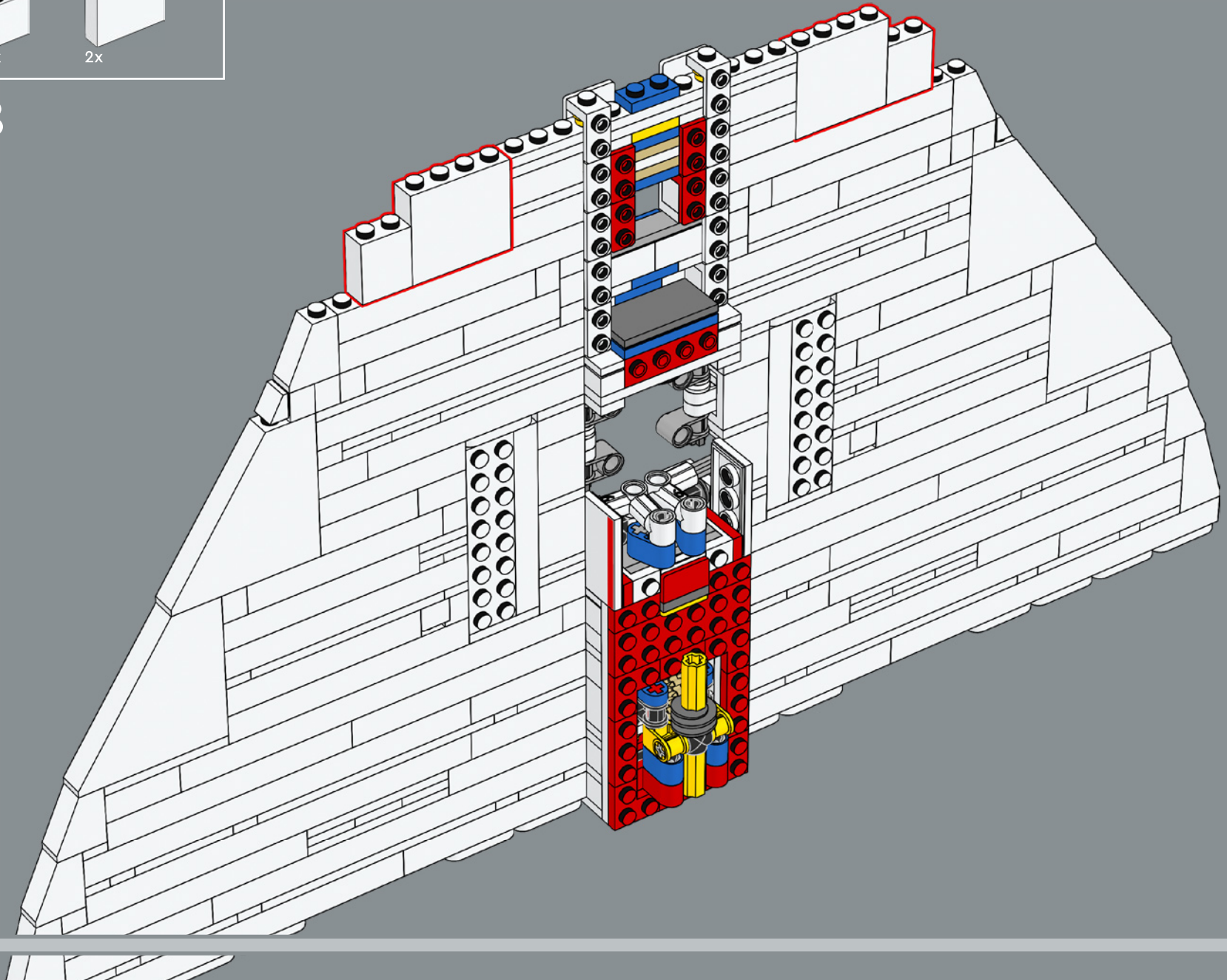

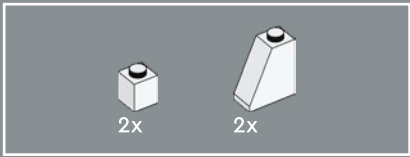

109

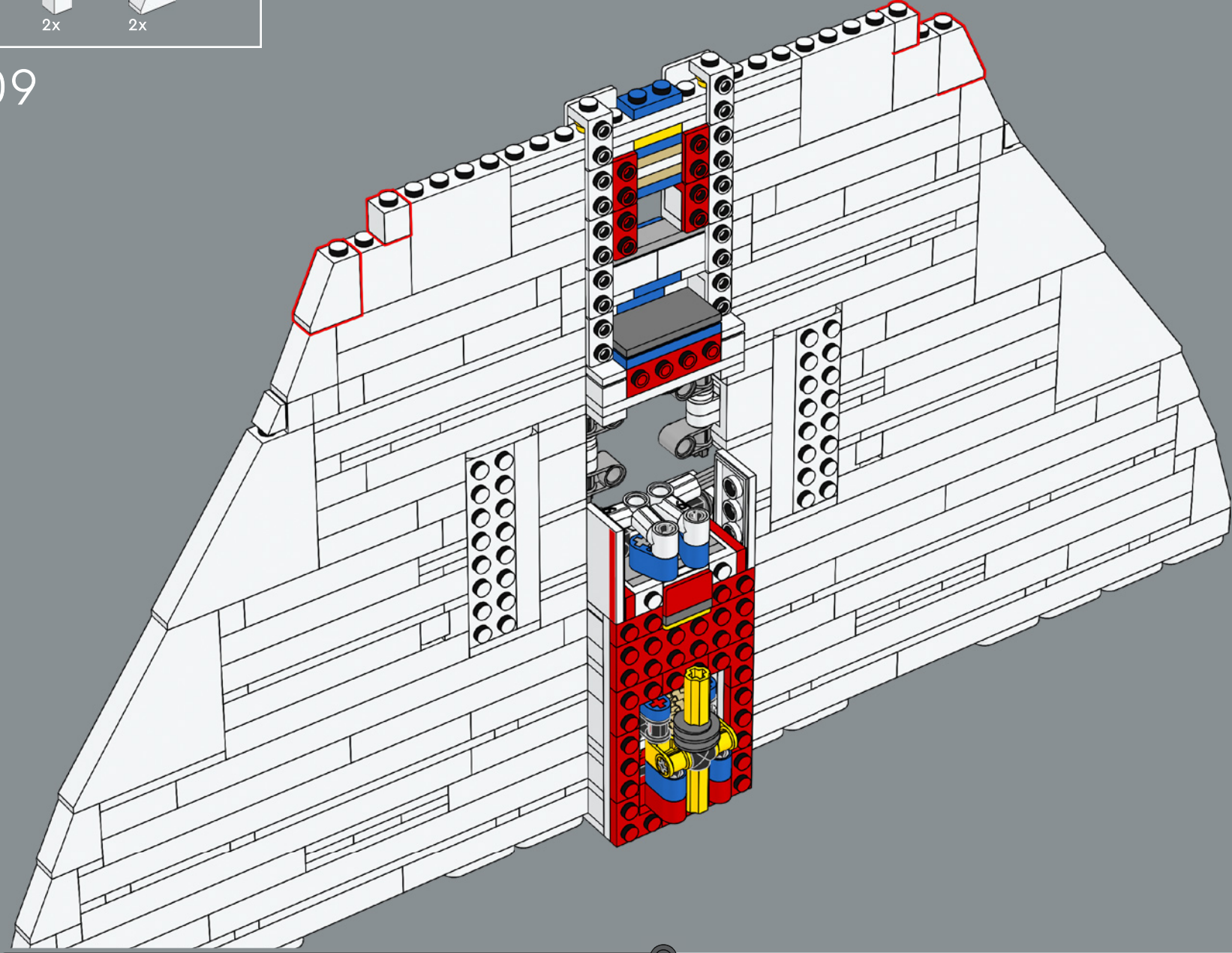

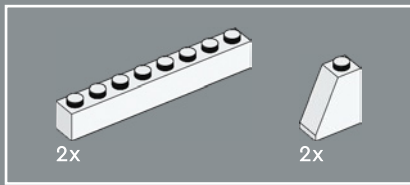

110

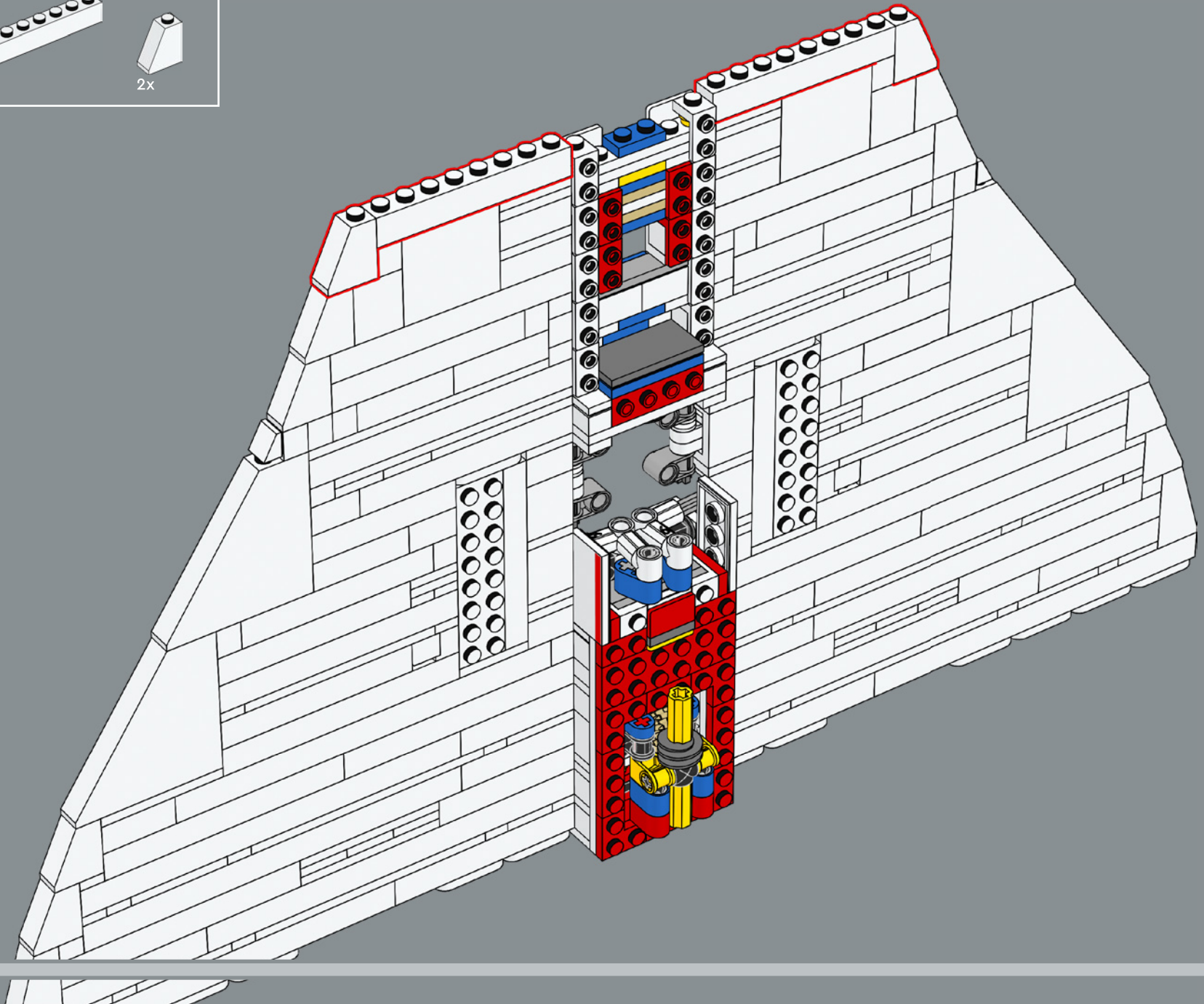

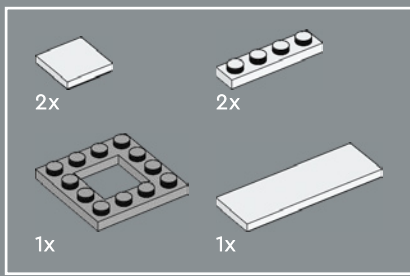

111

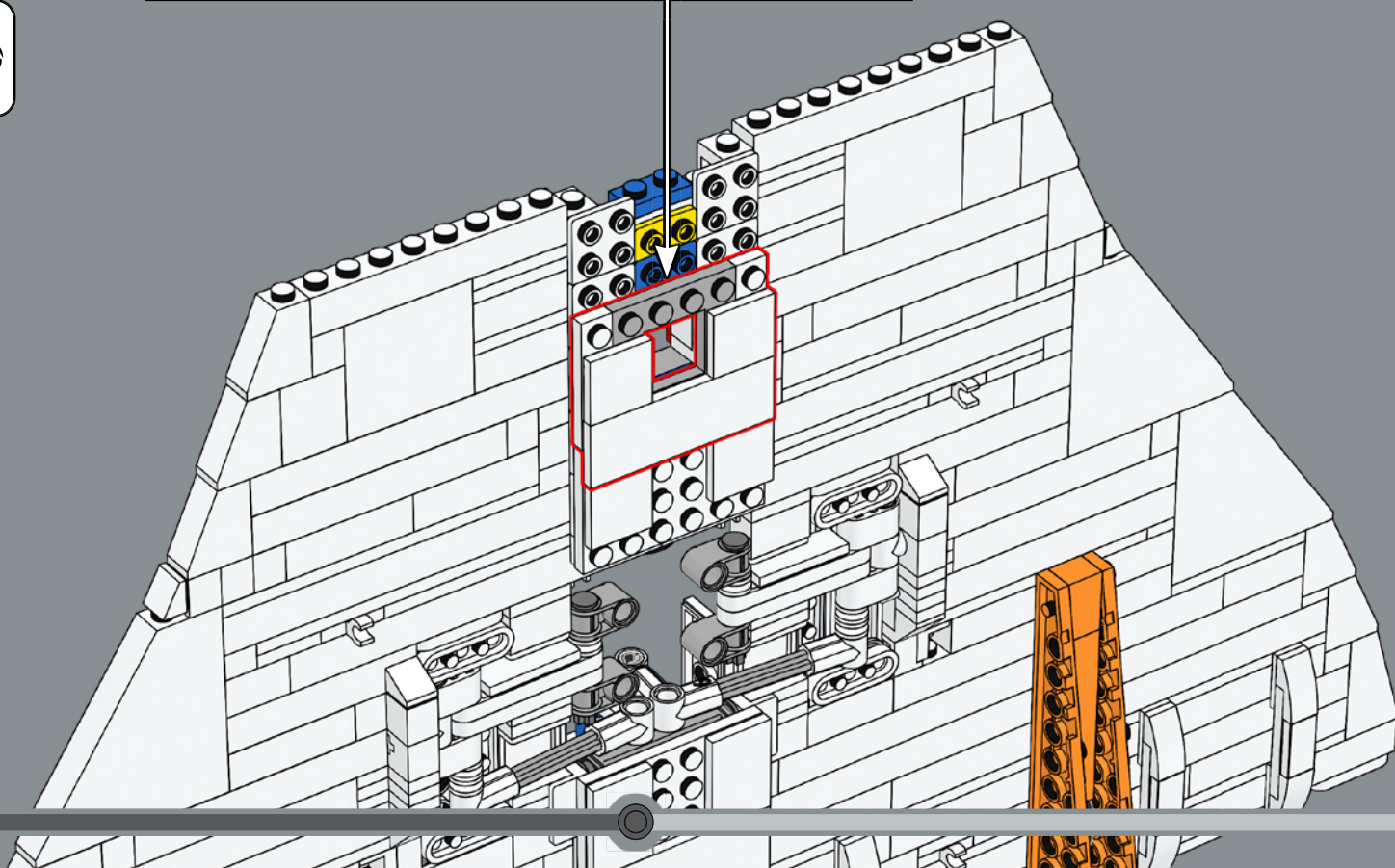
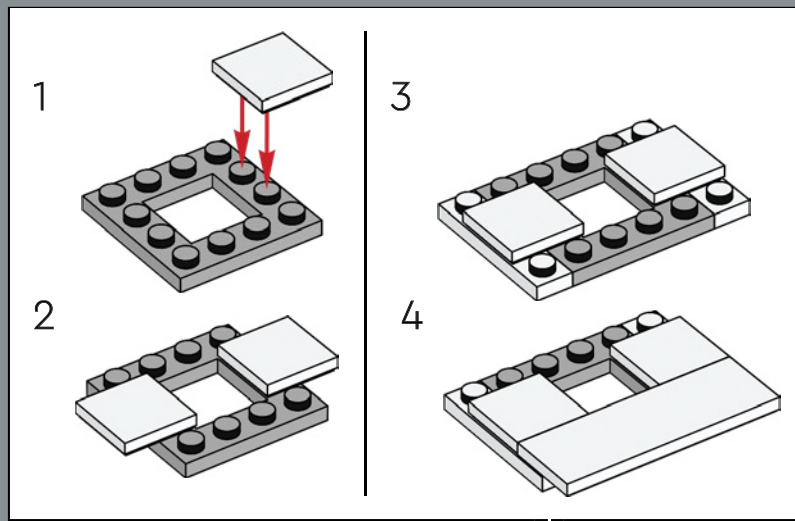



112

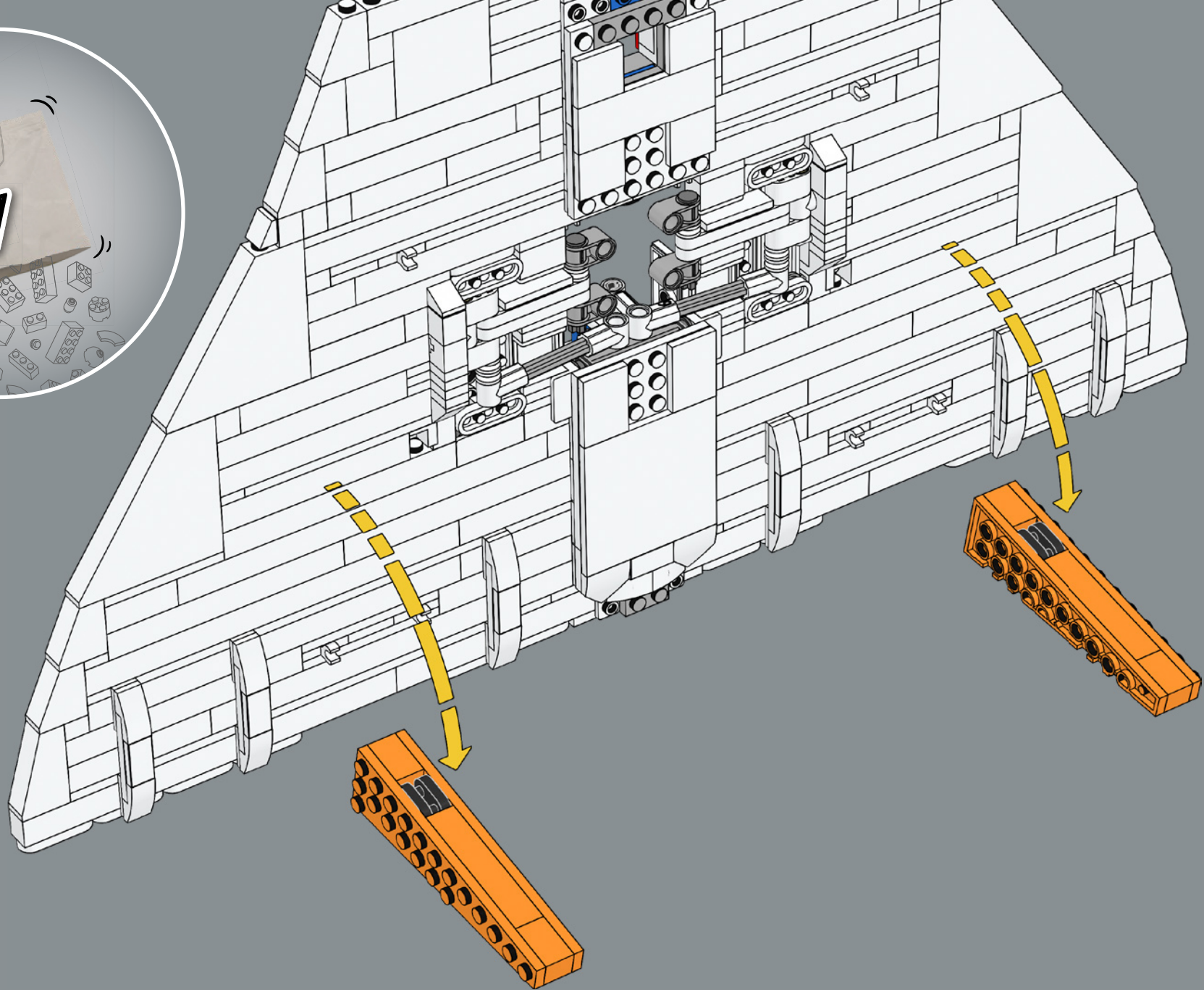

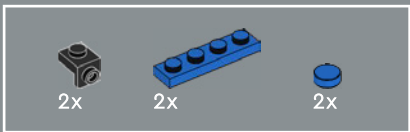

113

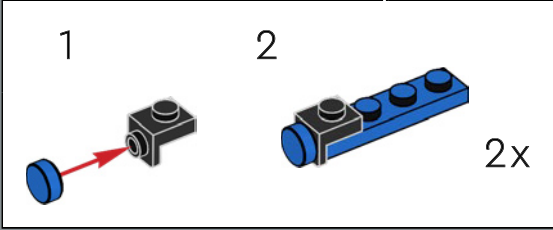
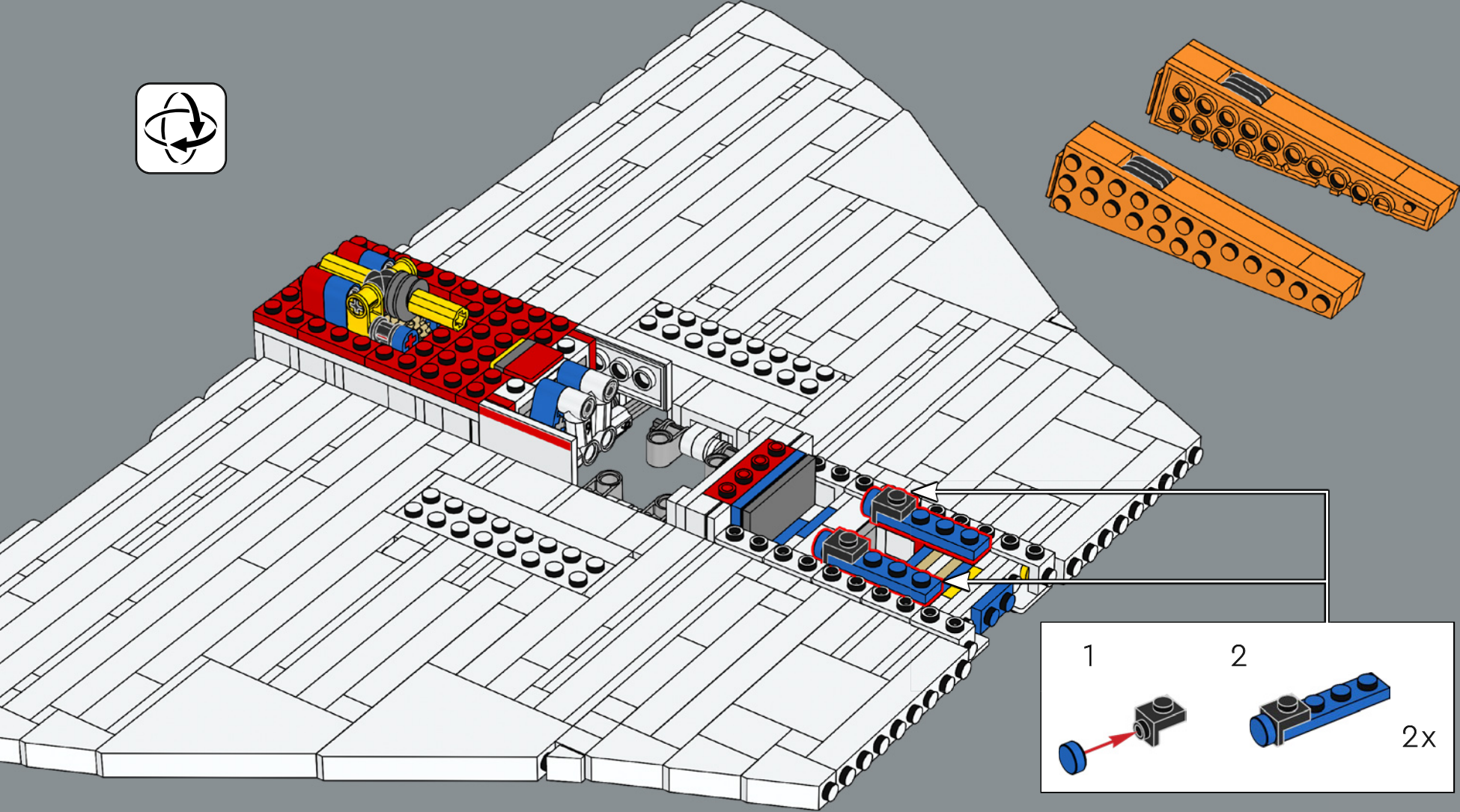

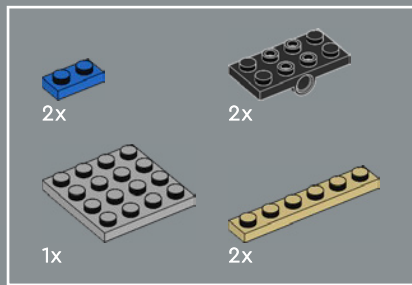

114

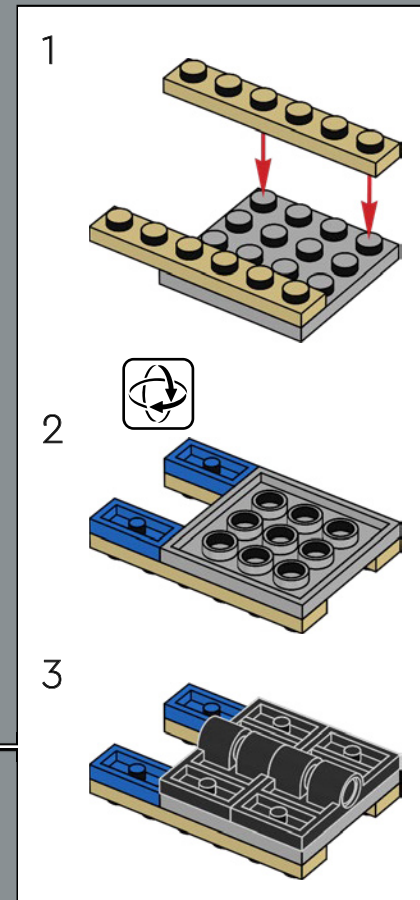
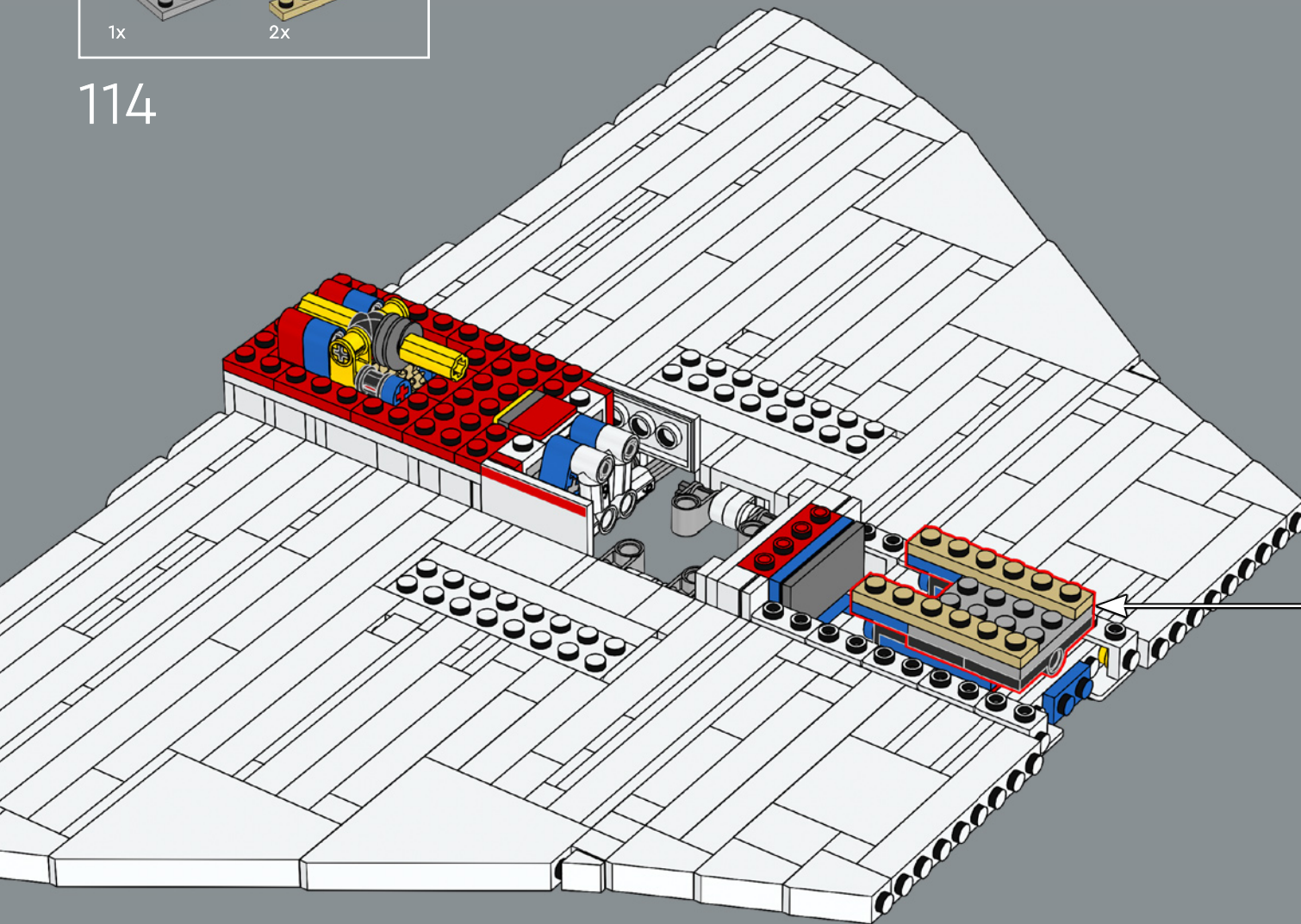

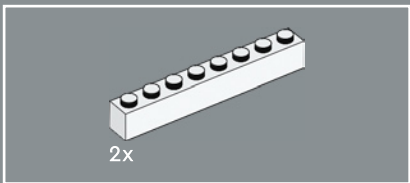

115

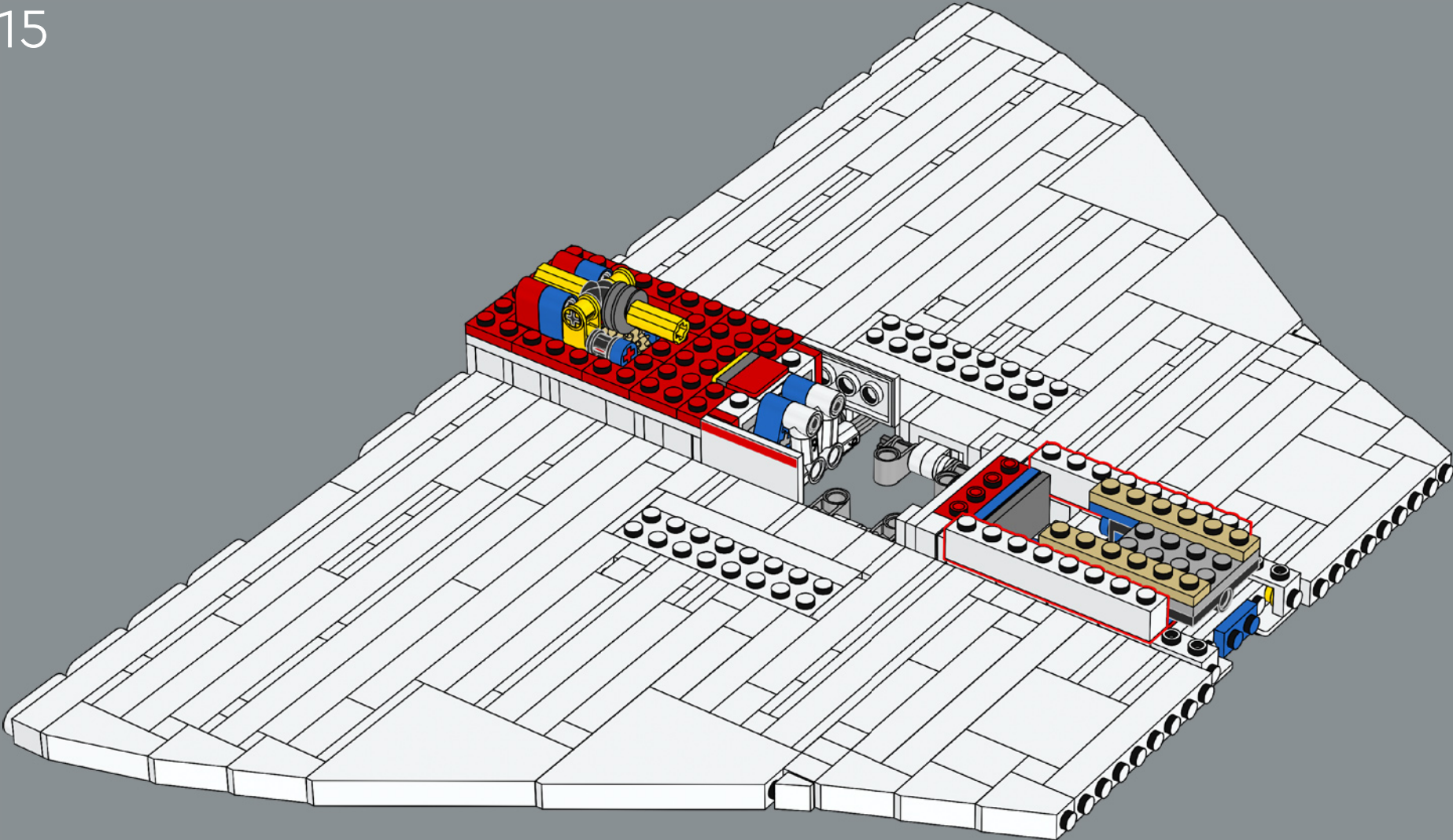



尽管乘客可以期待协和式飞机的豪华体验，
但飞机的窗户相当小，大小与你的手差不多。

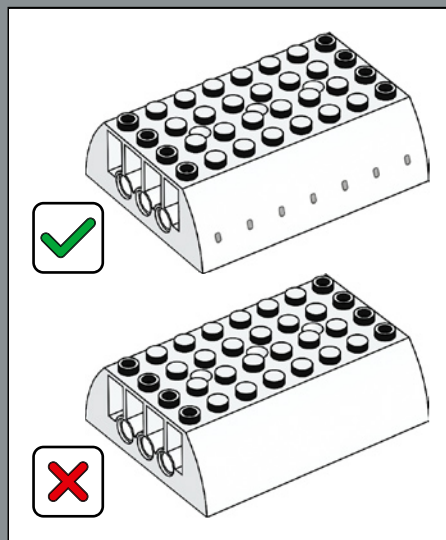
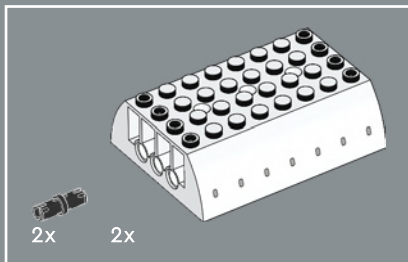
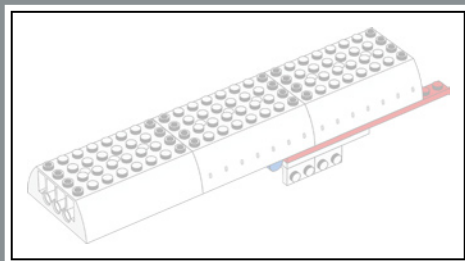

116

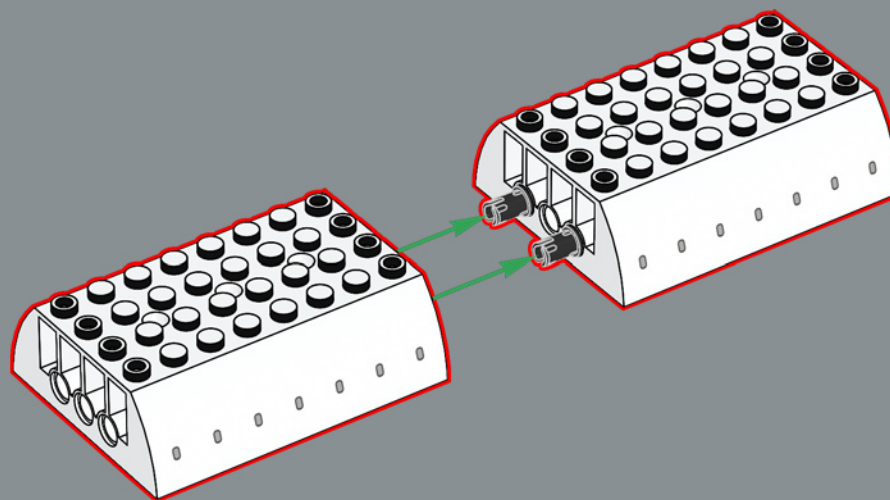

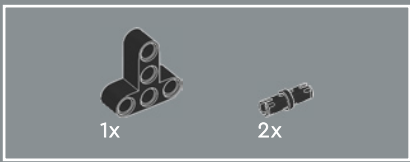

117

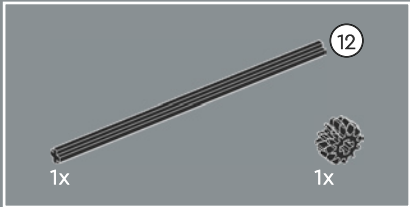
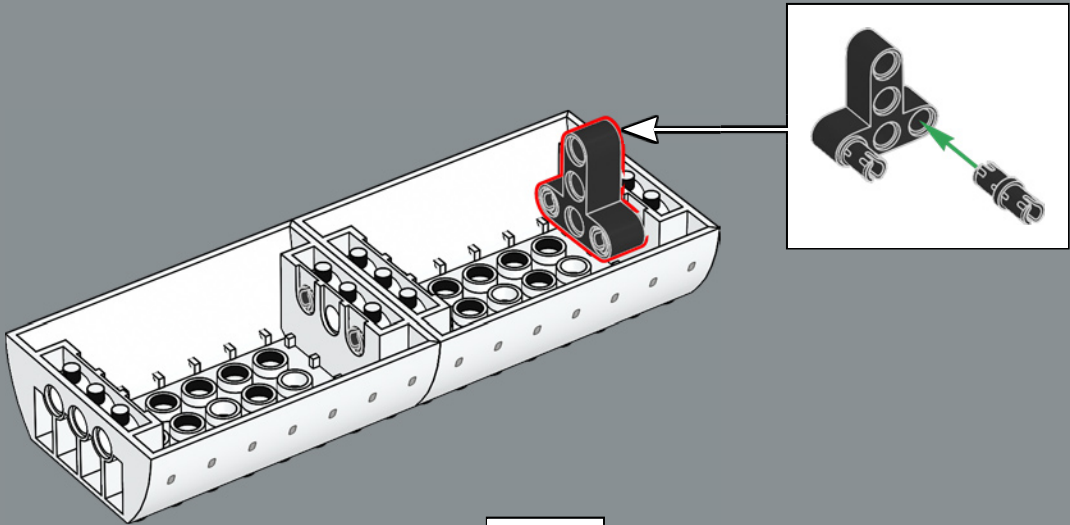

118

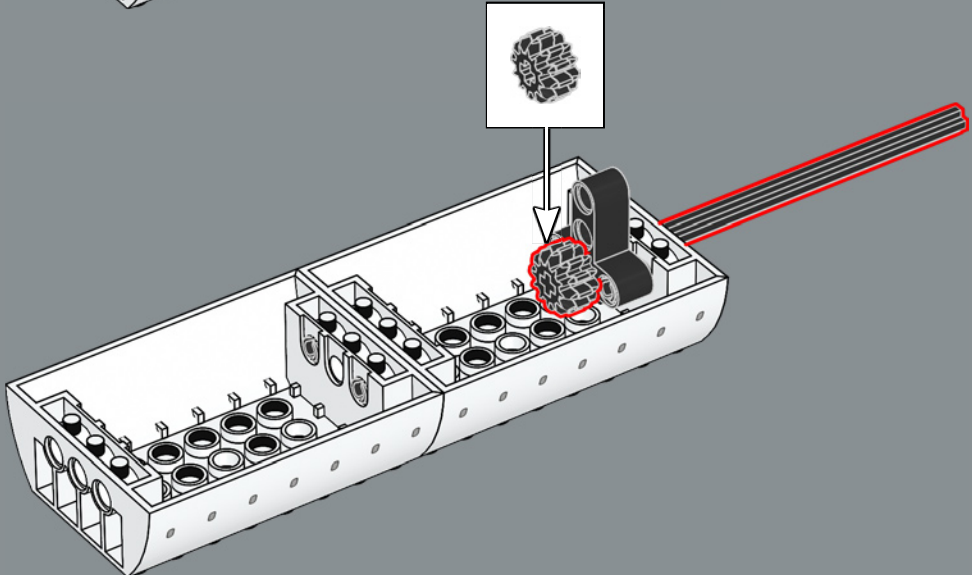

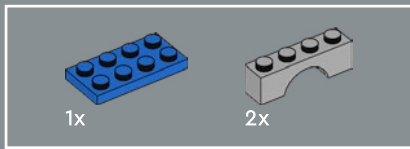

119

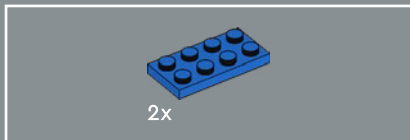
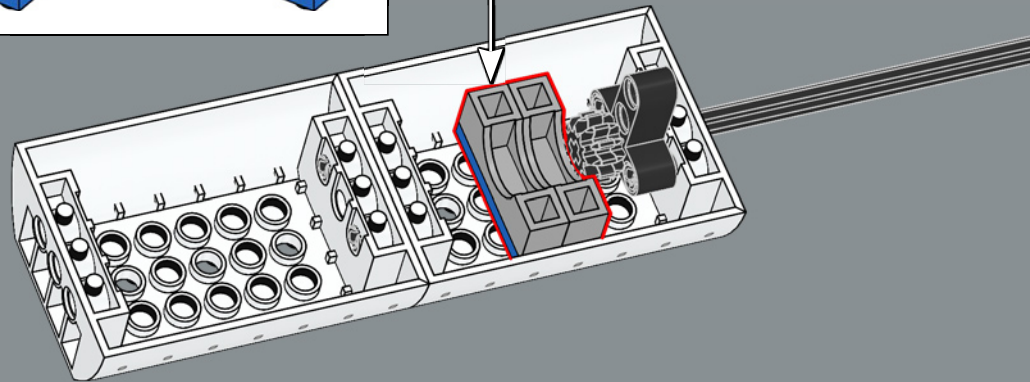
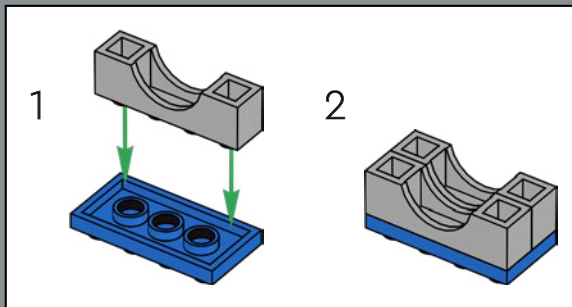

120

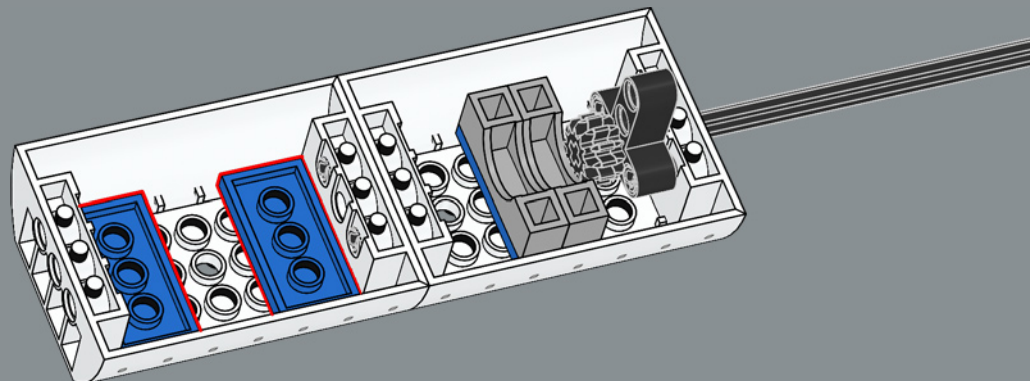

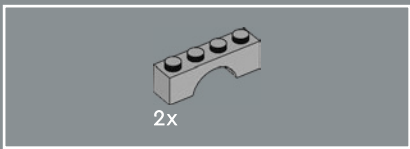

121

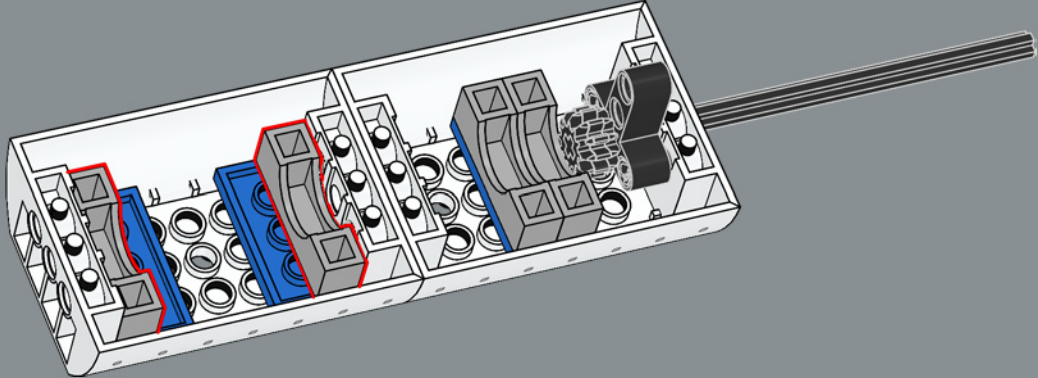

122

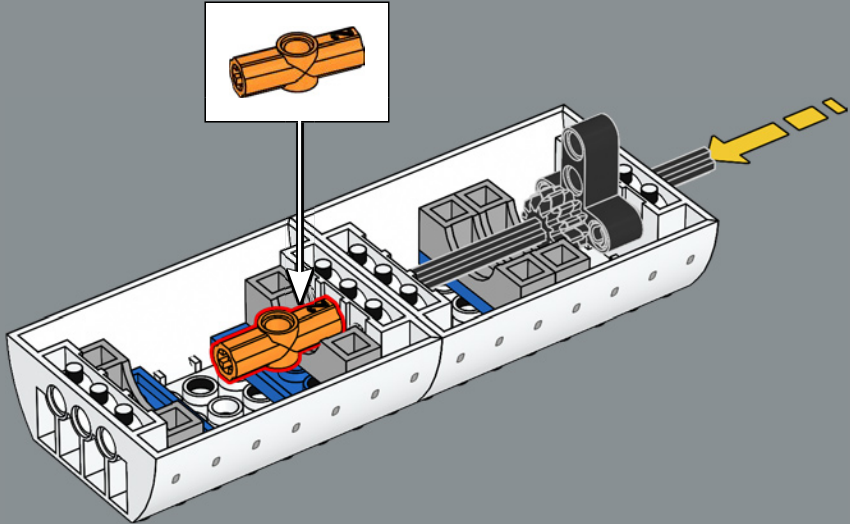

这个橙色小组件不仅可以连接主起落架的驱动轴，而且可以在你准备拼搭其它模型时用于拆解你的乐高®模型！

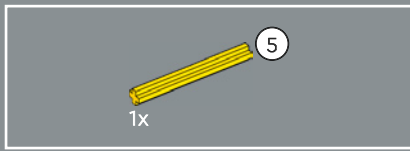

123

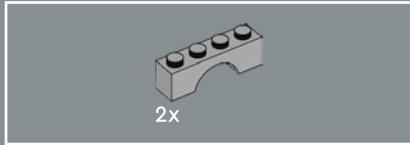
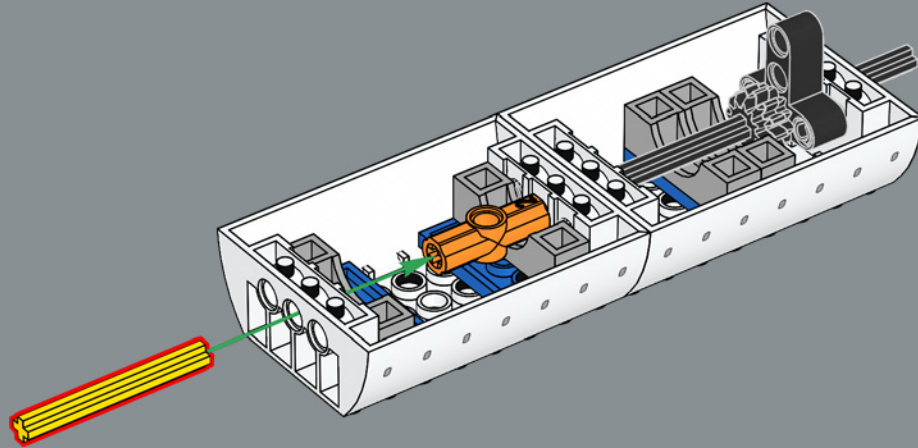

124

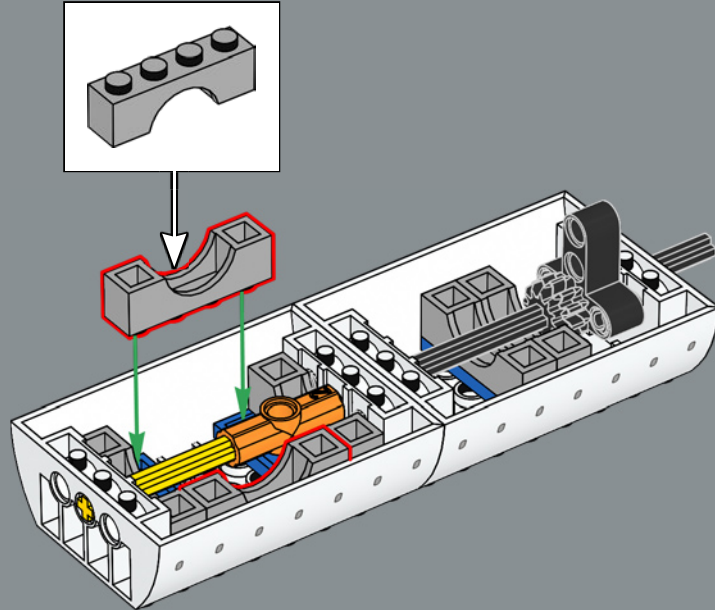



6x

125

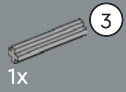
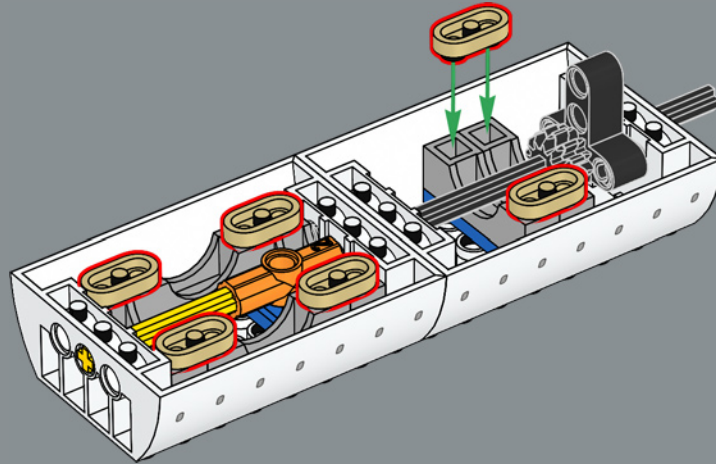

126

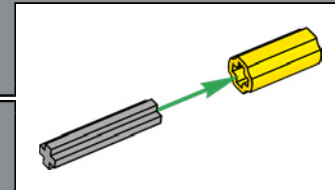
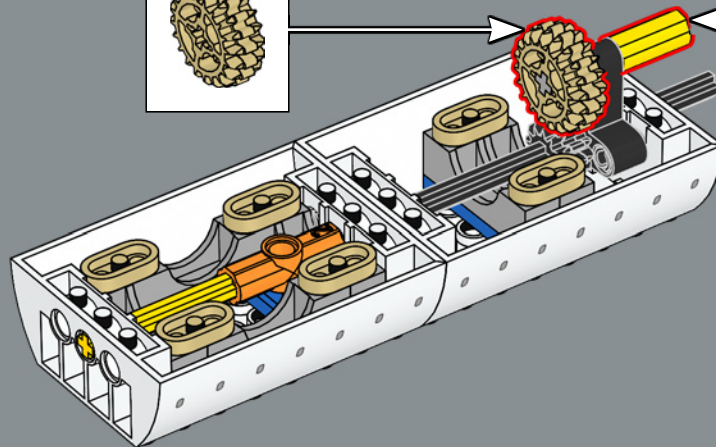
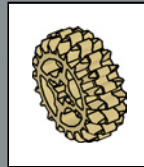

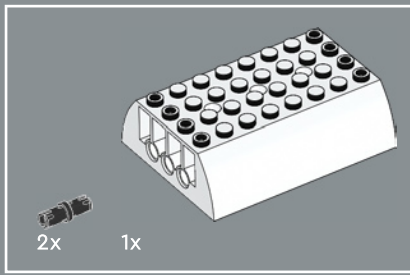

127

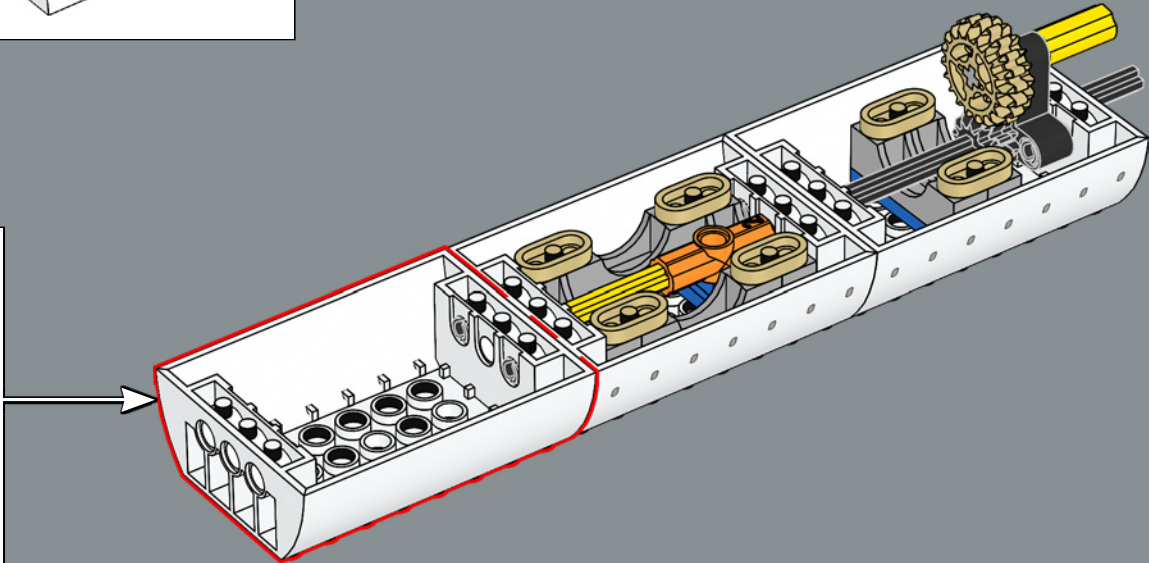
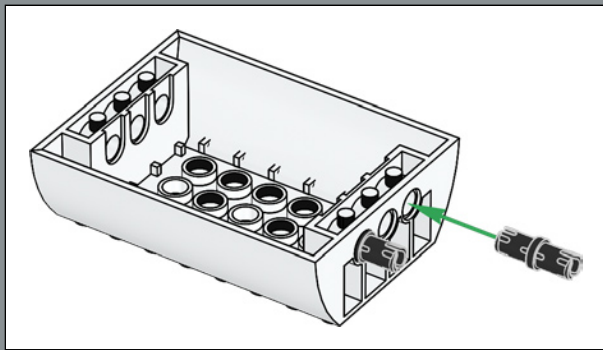
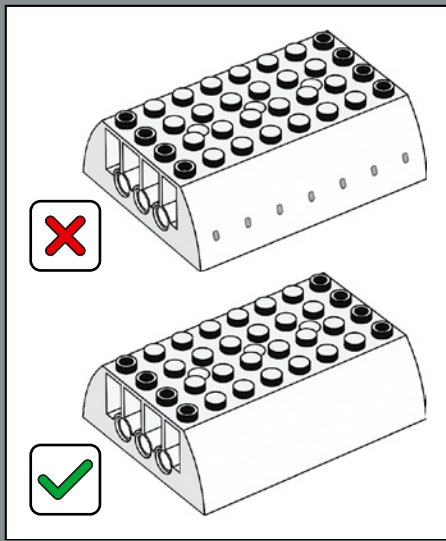

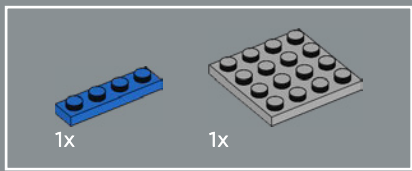

128

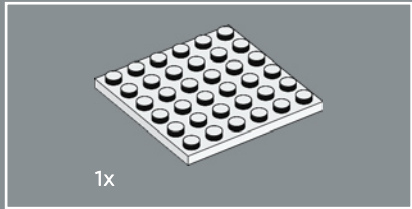
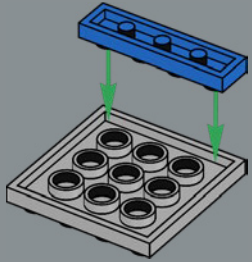

129

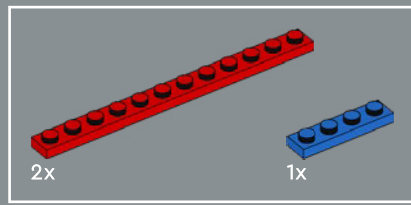
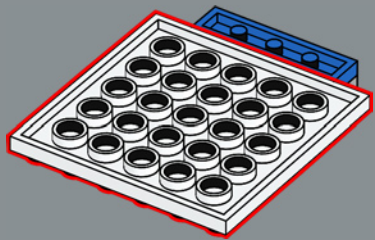

130

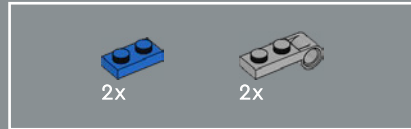
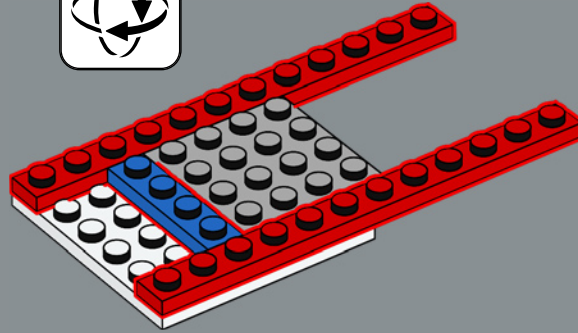

131

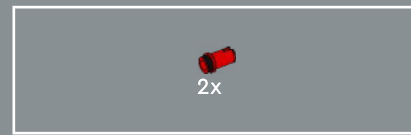
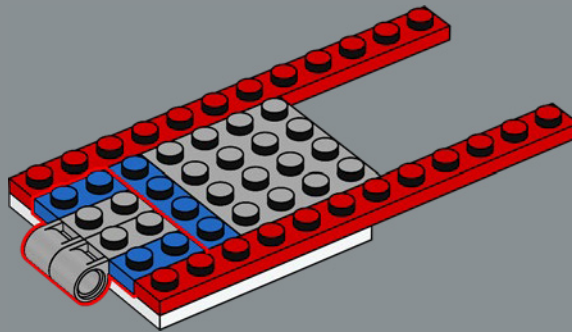

132

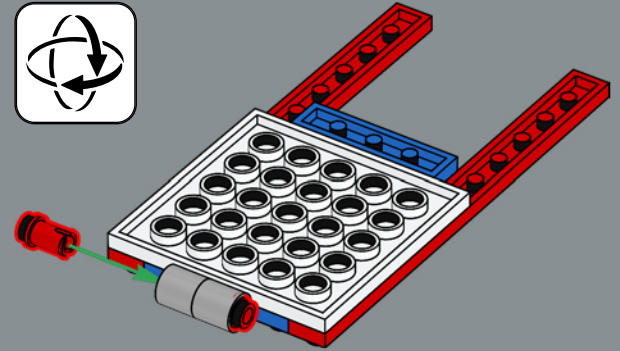

133

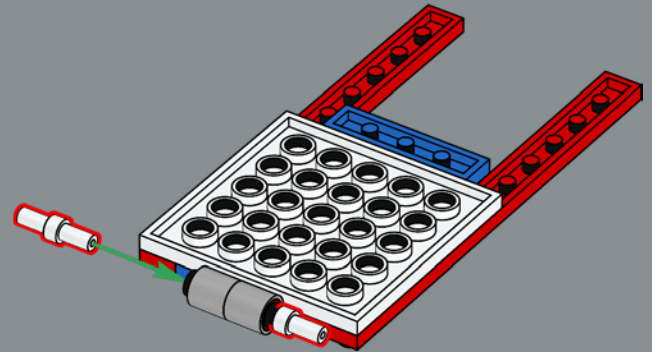



134

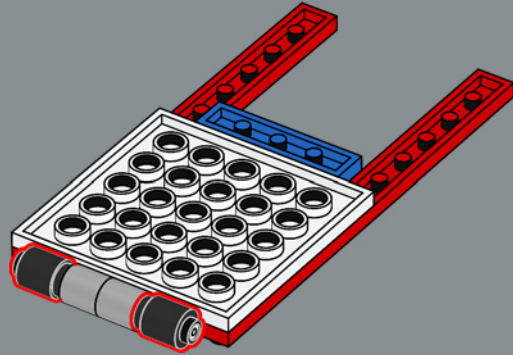

135

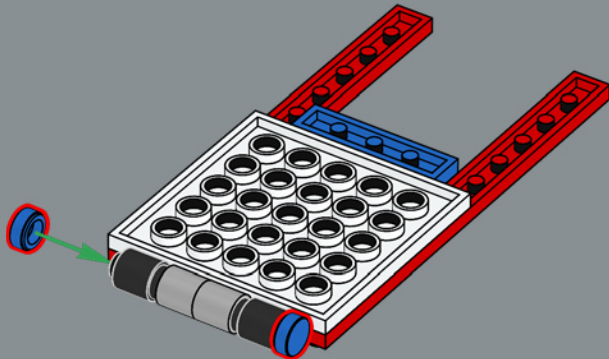

136

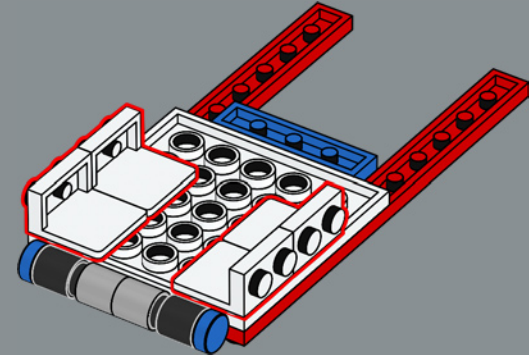

137

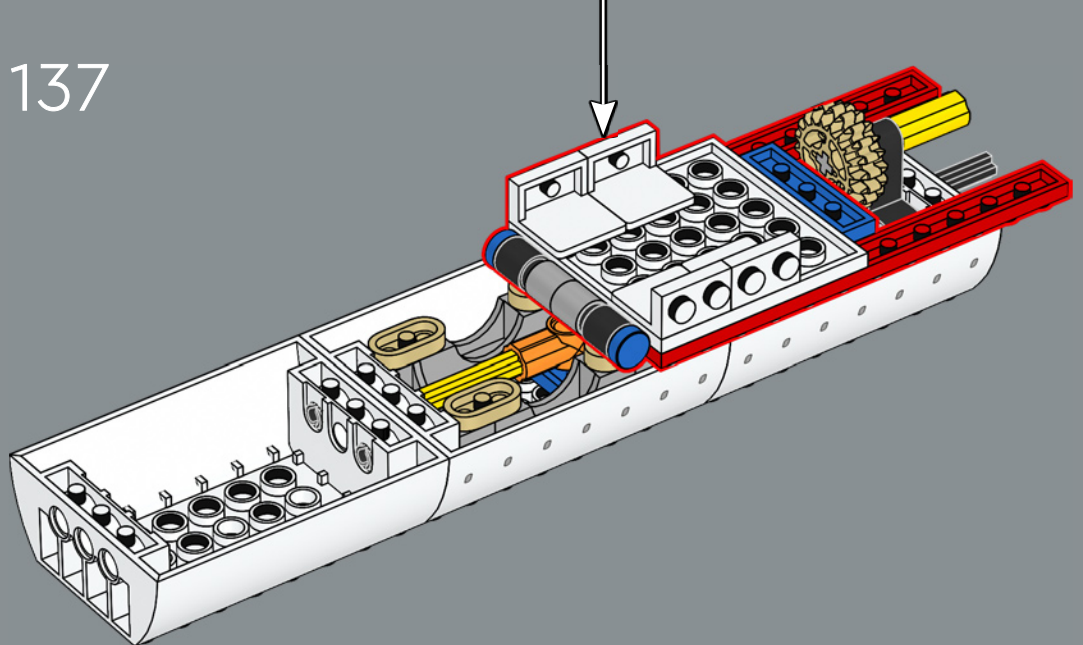

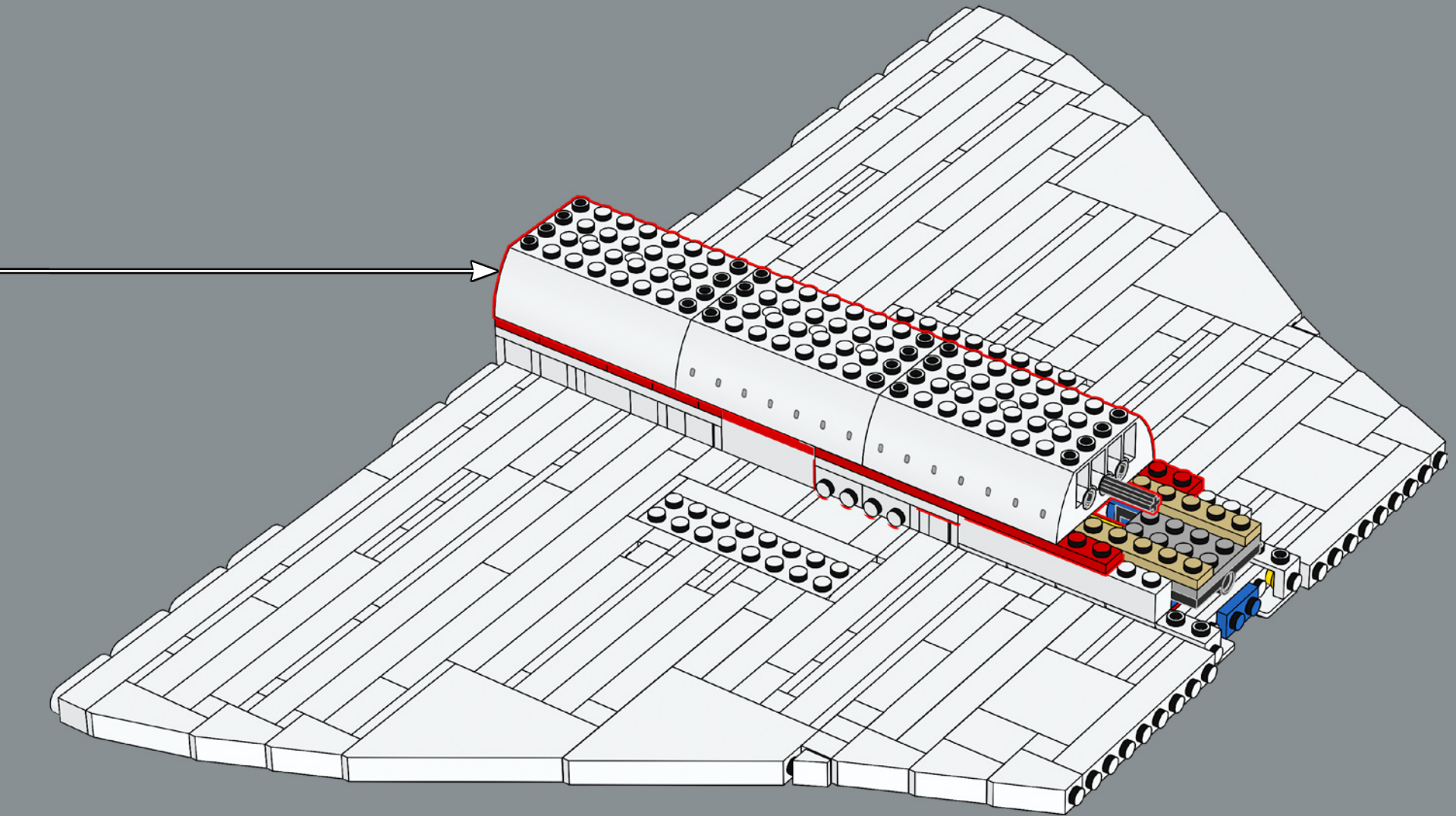

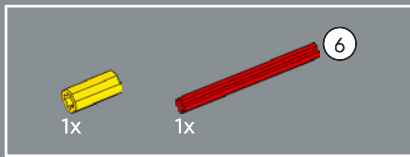

139

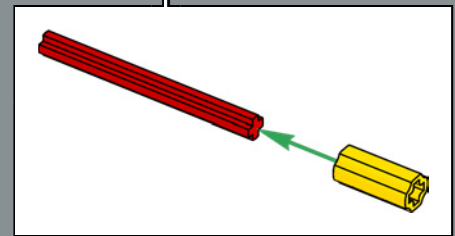
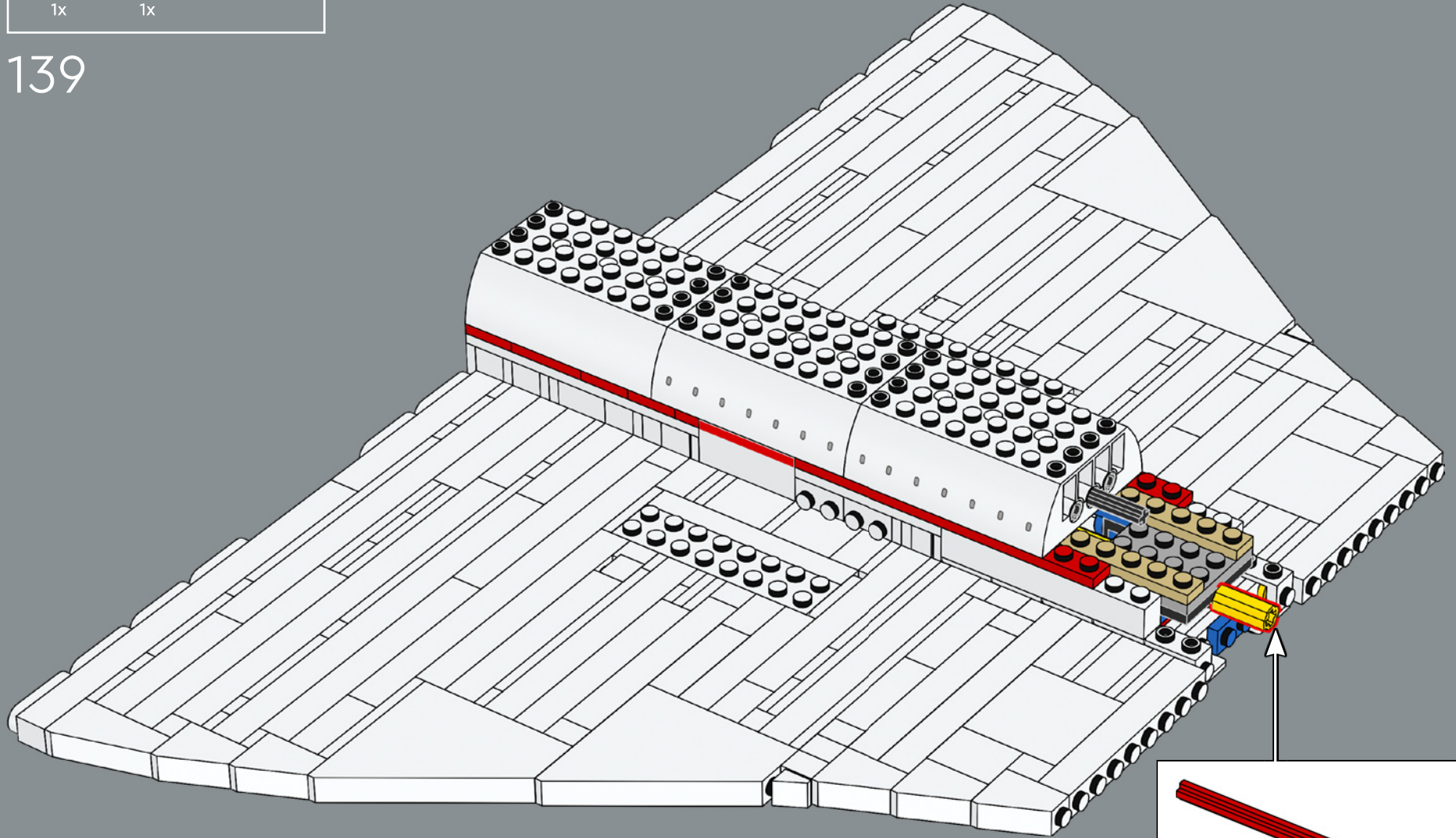

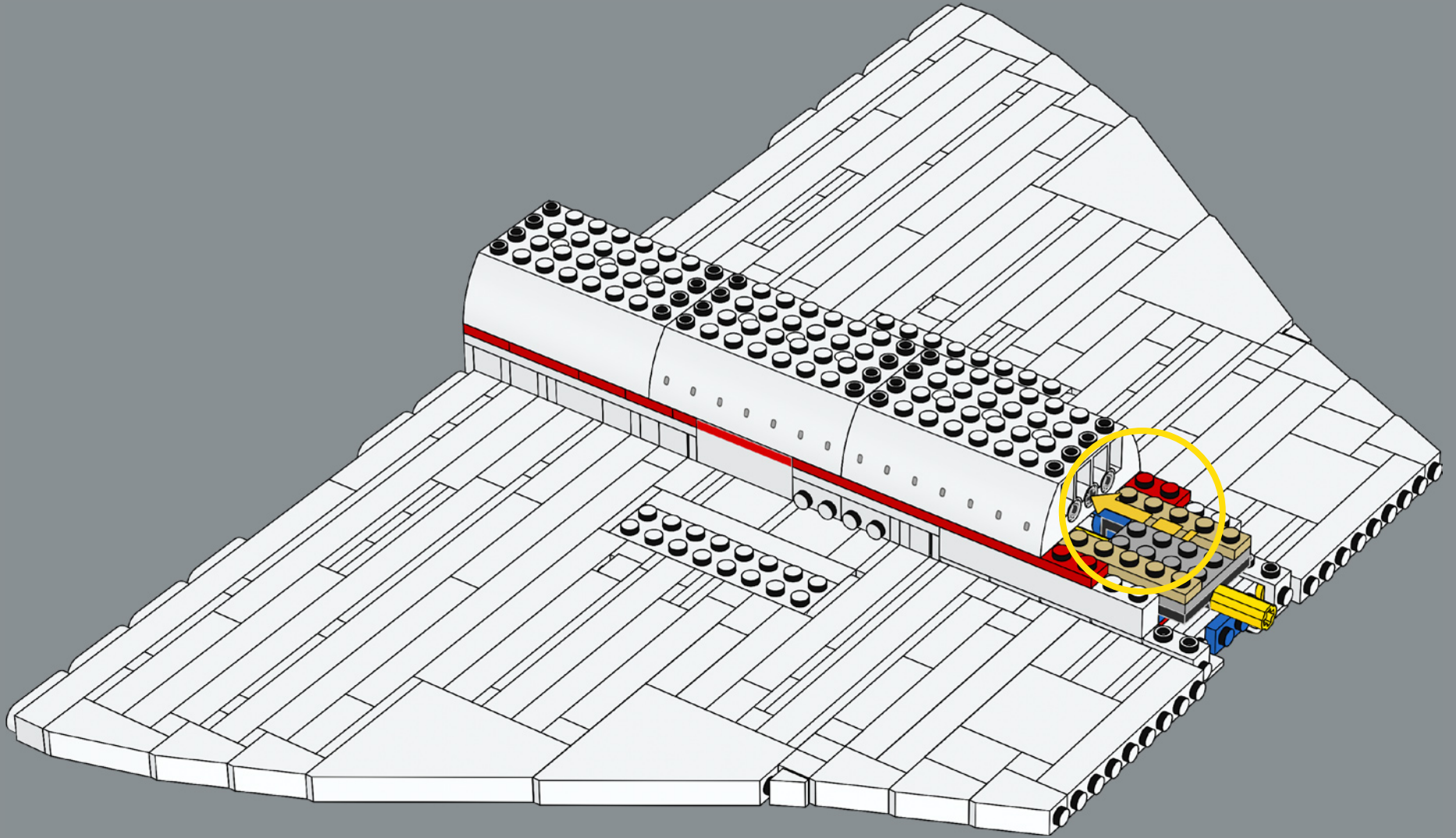

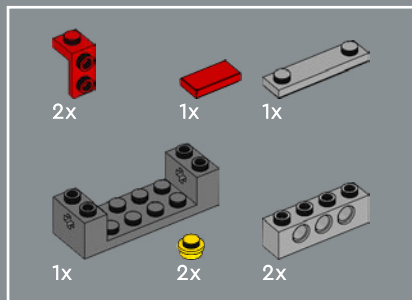

141

1

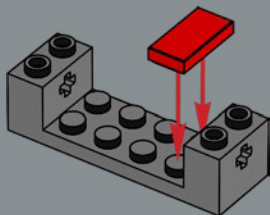

2

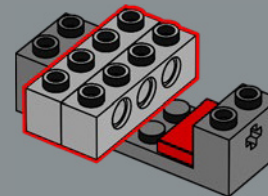

1

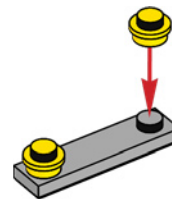

2

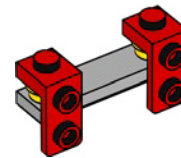

3

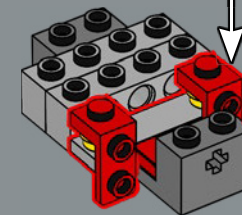



协和式飞机的细长的外形对乐高®积木提出了真正的挑战，为了将所有组件固定在一起，我们使用这个有趣的小锁将机身固定在巨大的三角翼上。

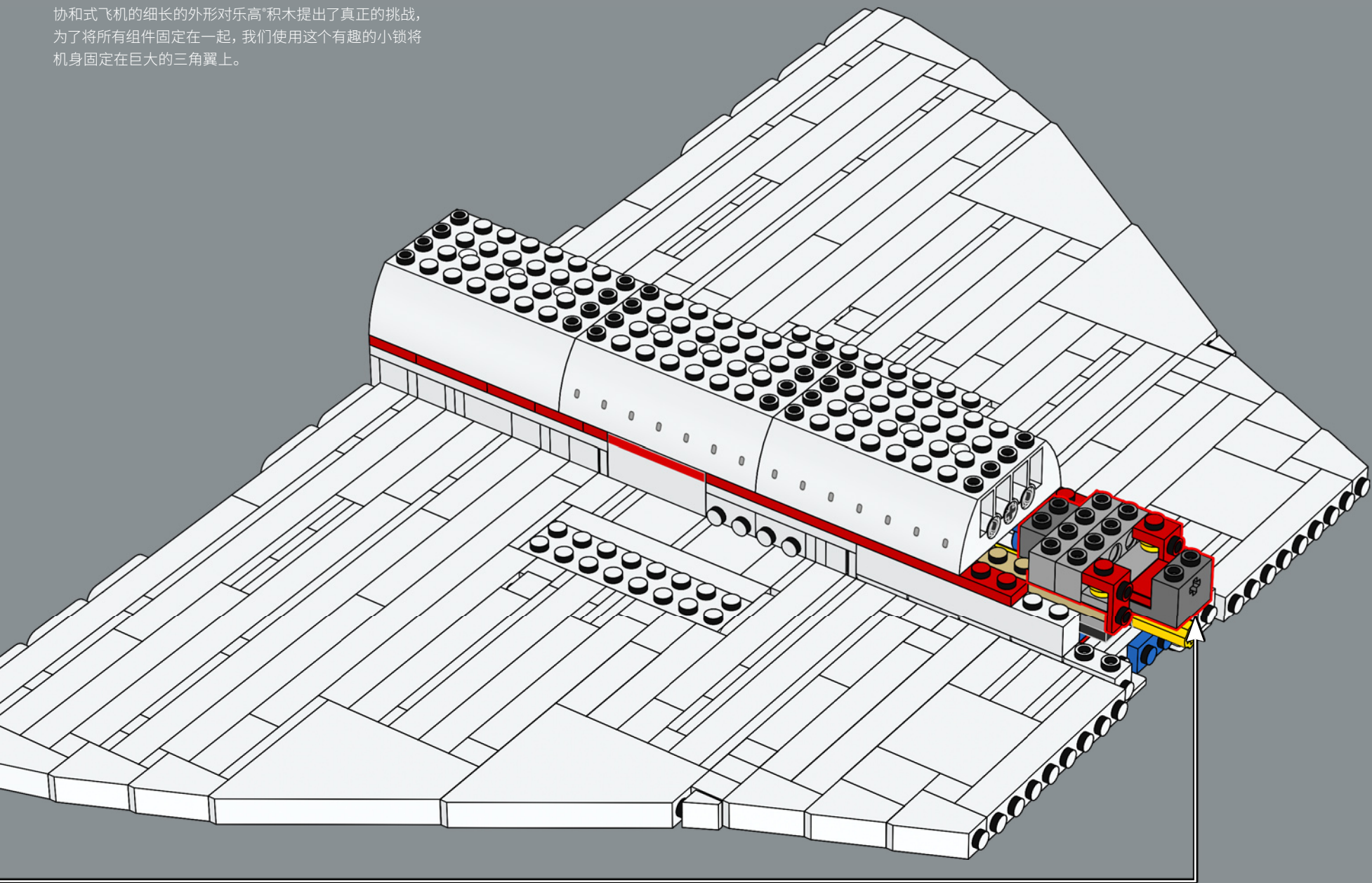

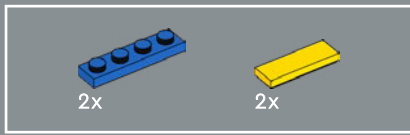

142

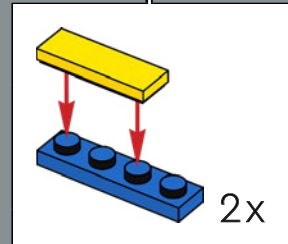
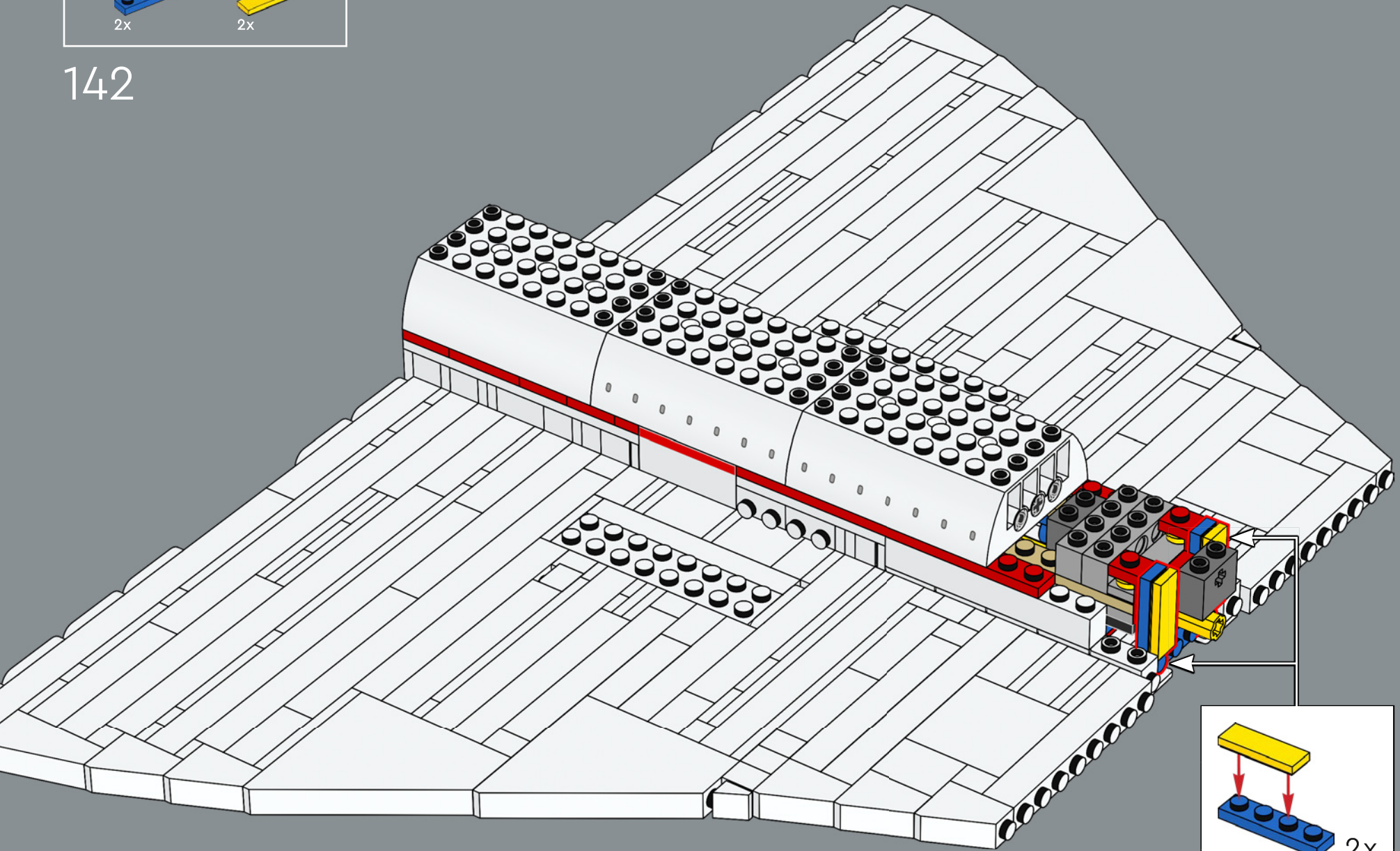

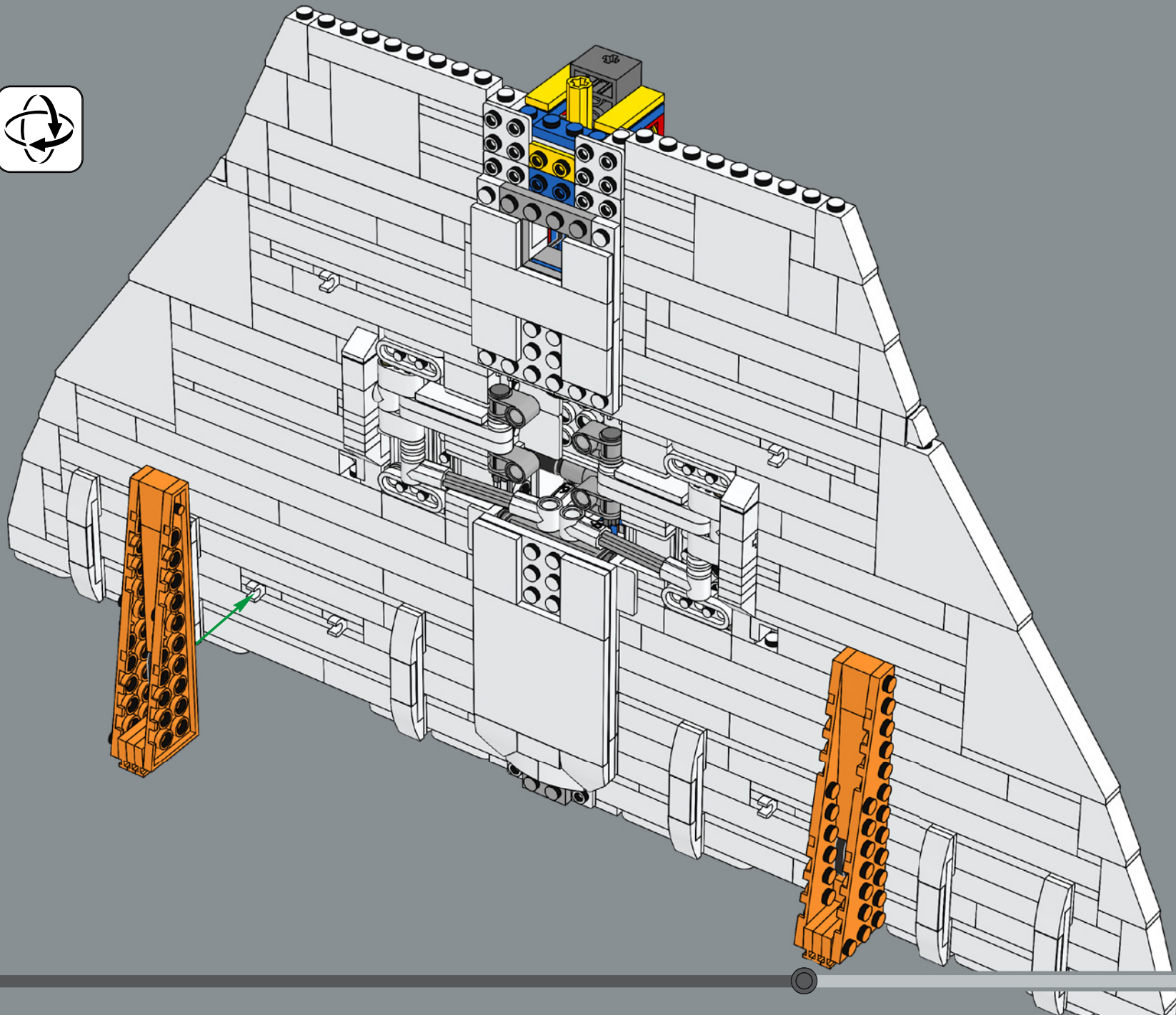

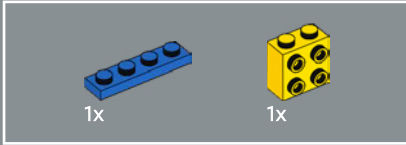
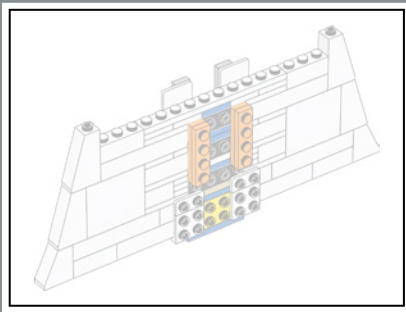

144

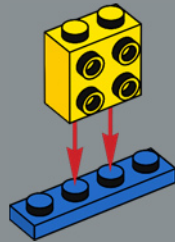

145

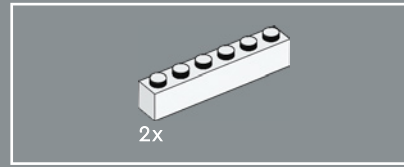
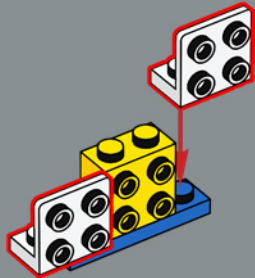

146

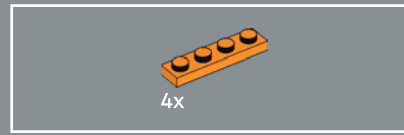
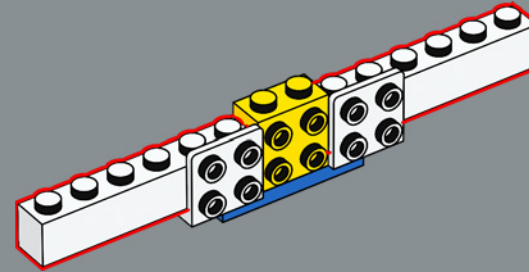

147

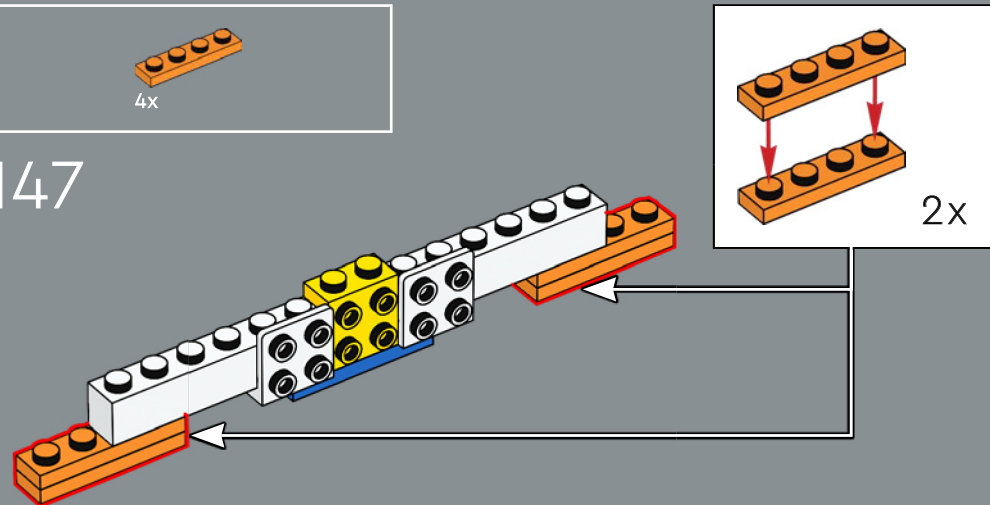

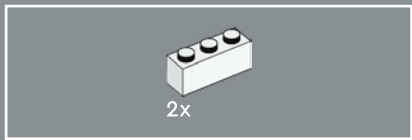

148

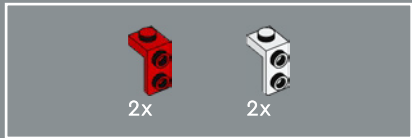
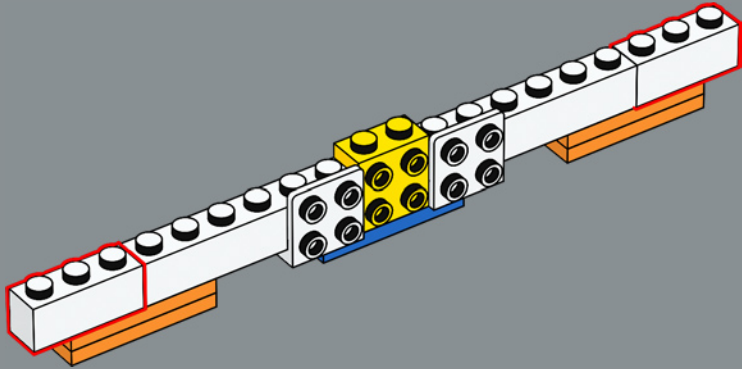

149

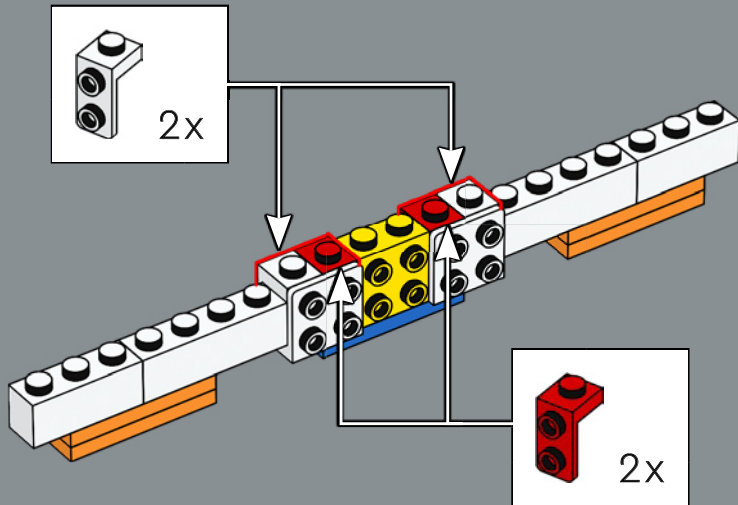

150

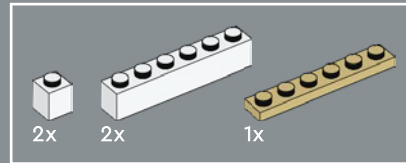
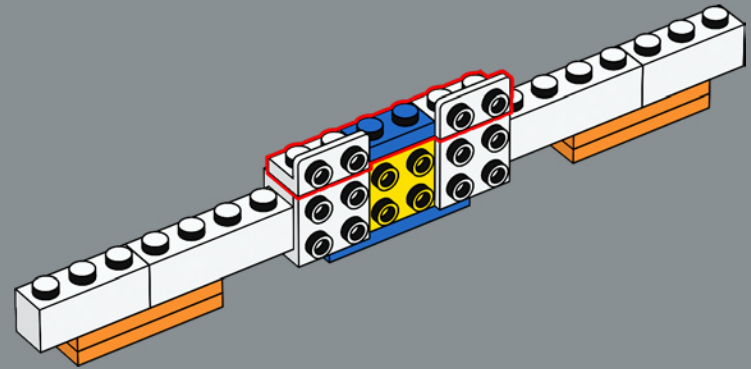

151

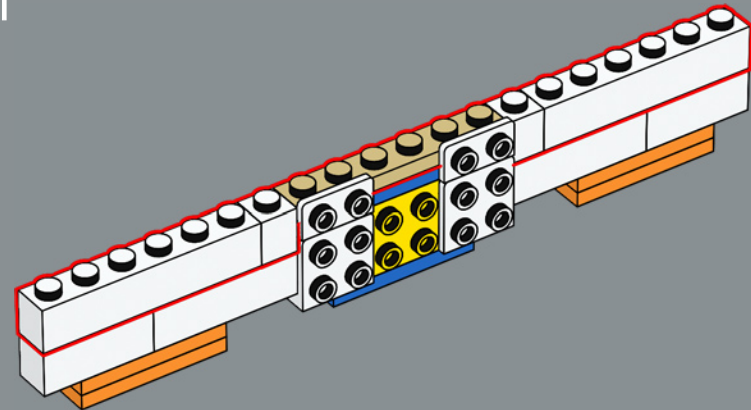

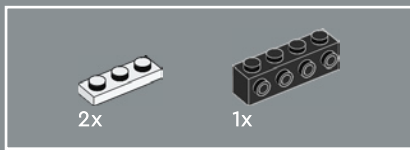

152

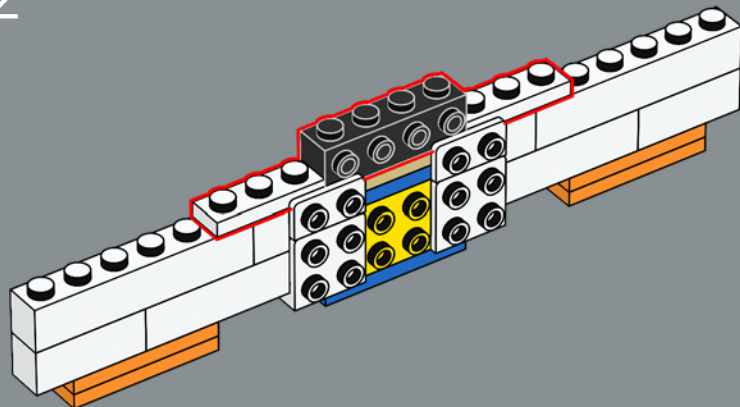

153

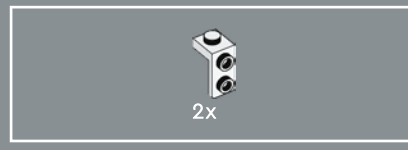
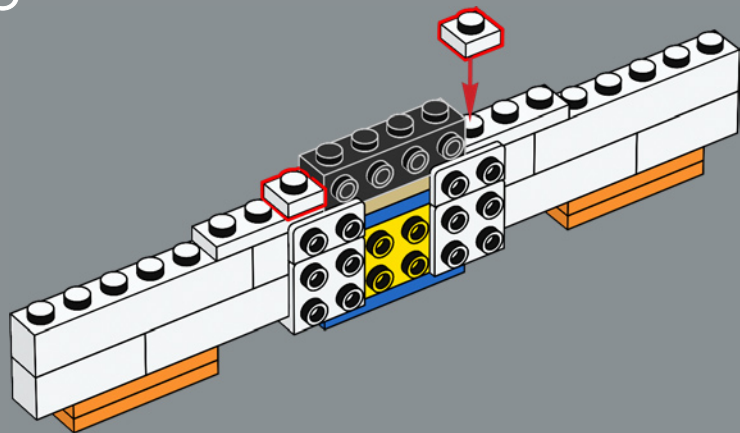

154

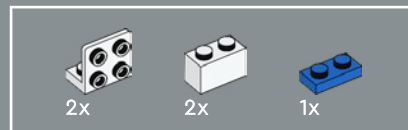
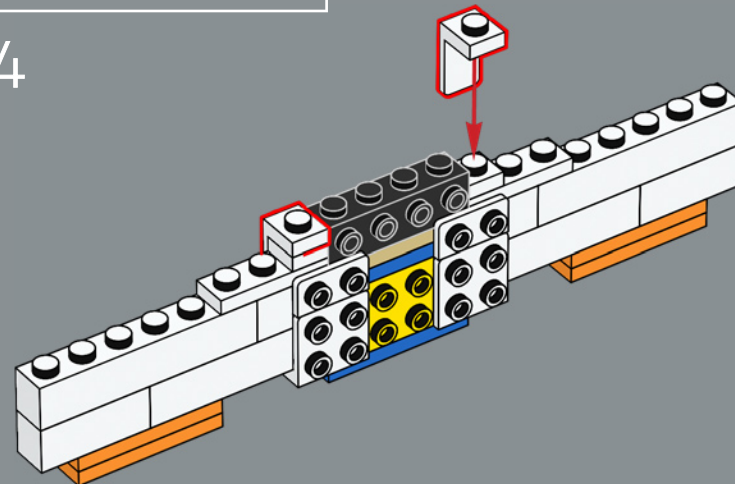

155

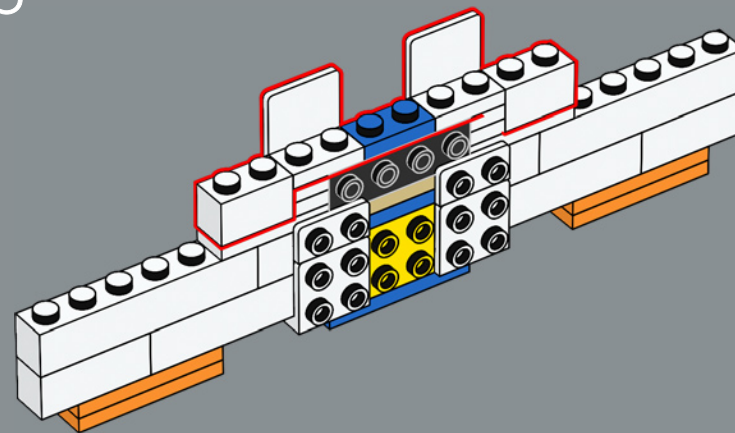

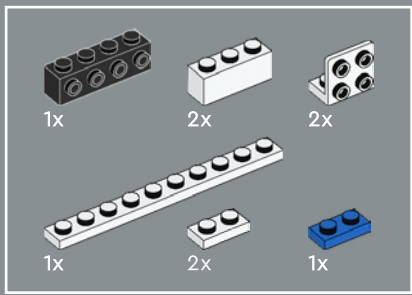

156

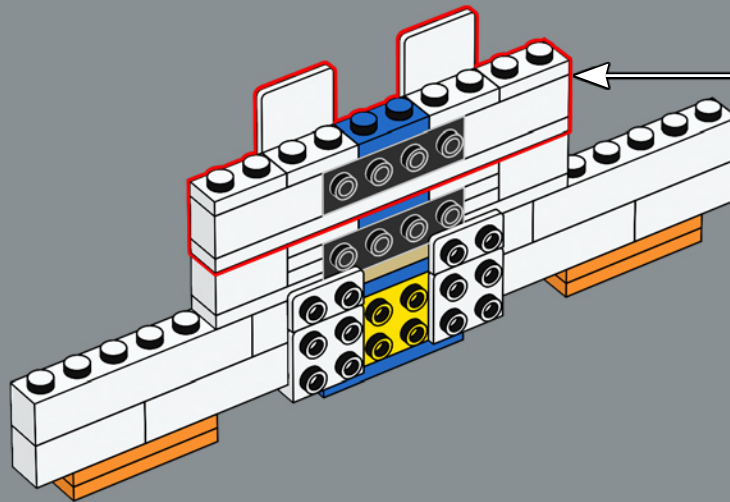
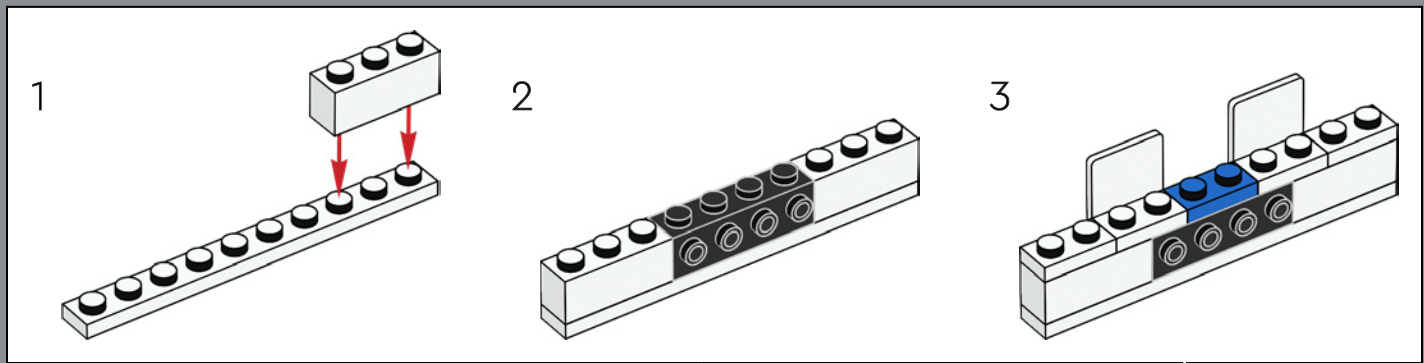

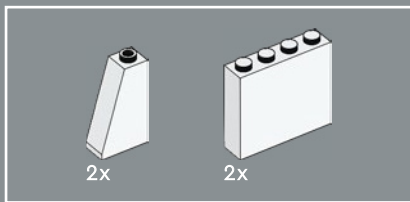

157

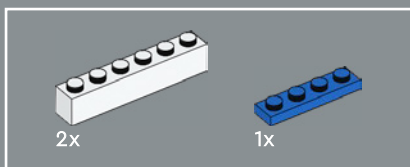
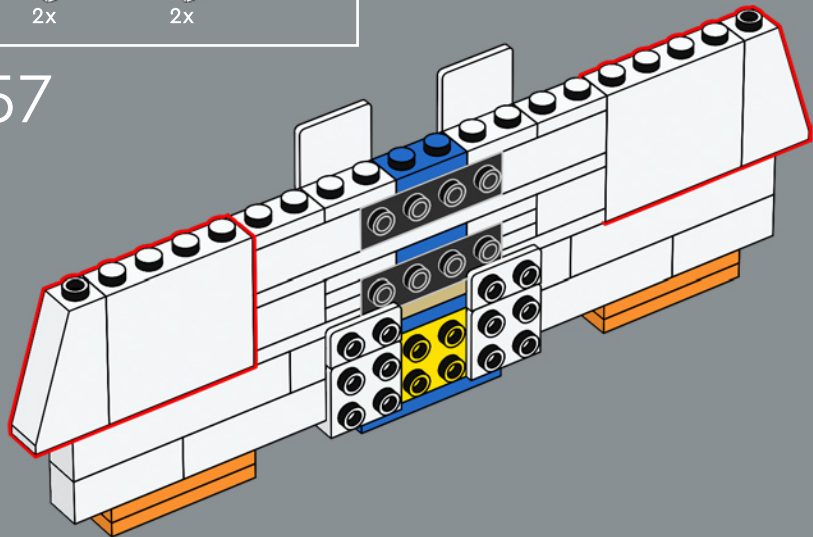

158

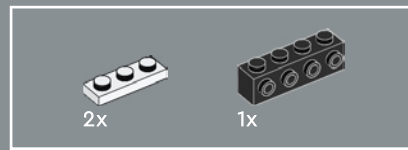
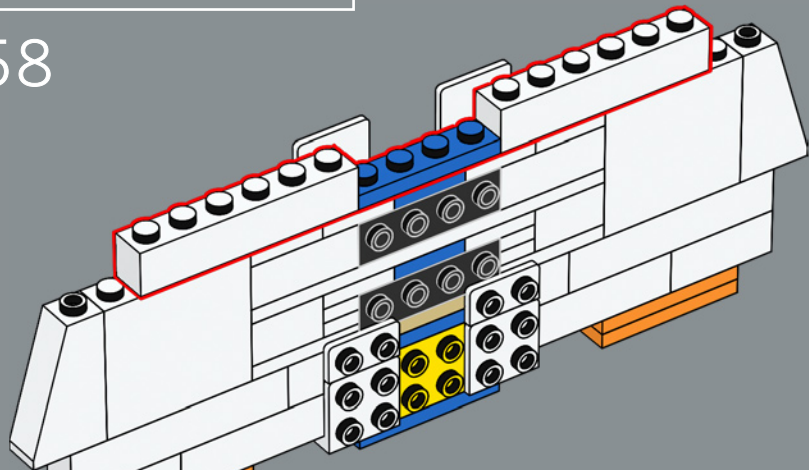

159

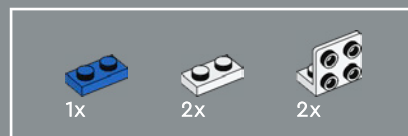
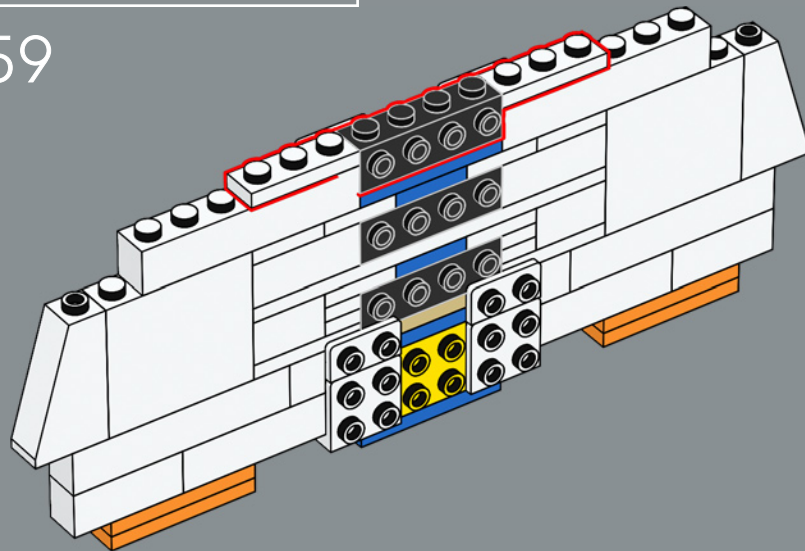

160

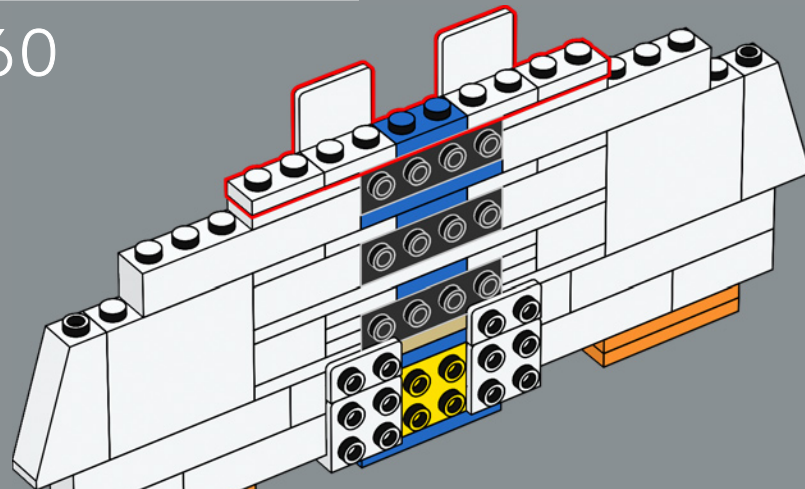

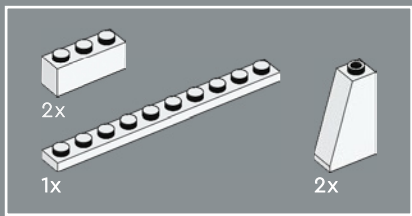

161

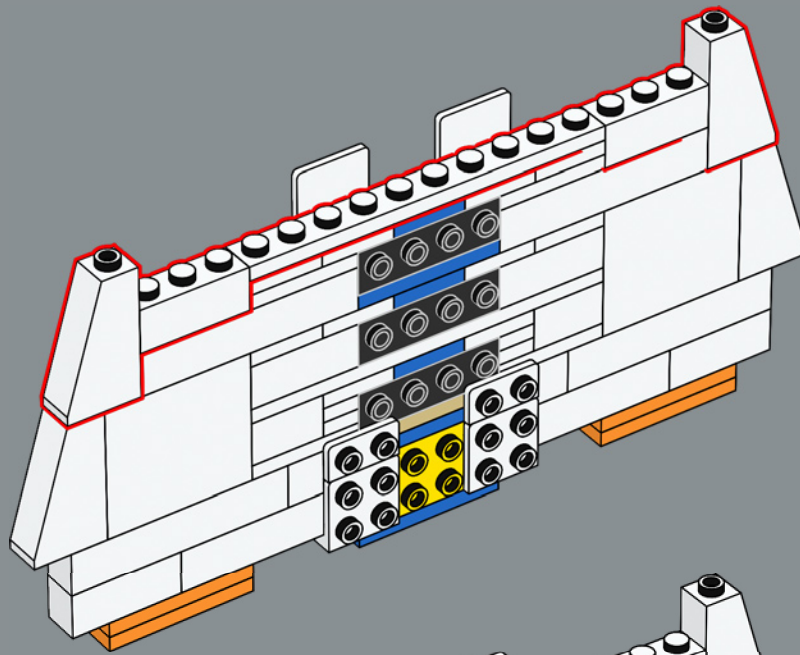

162

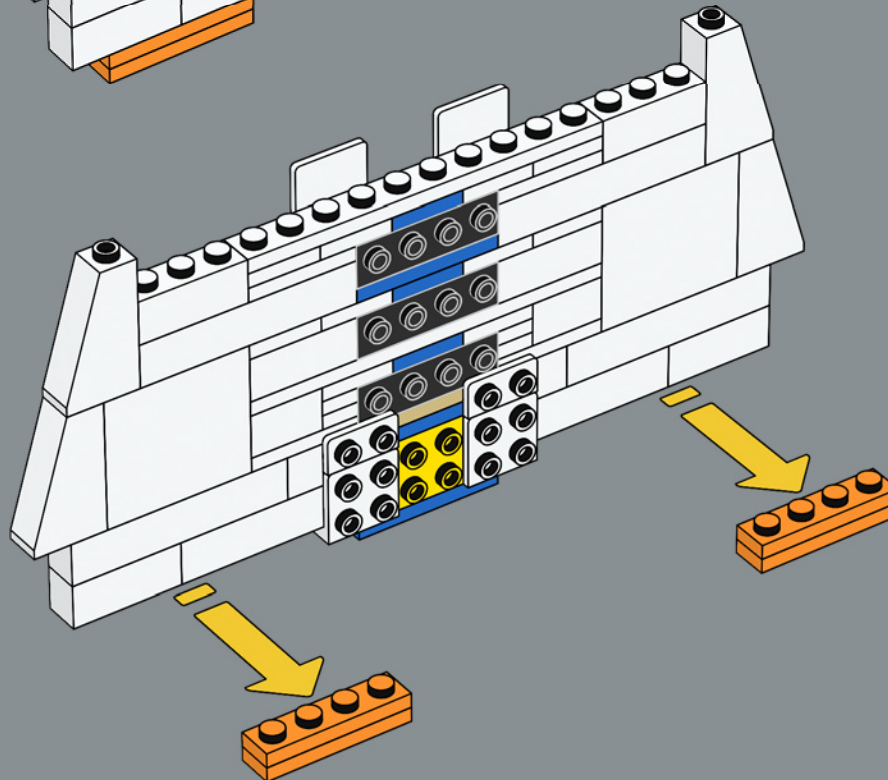

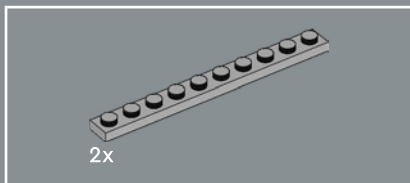

163

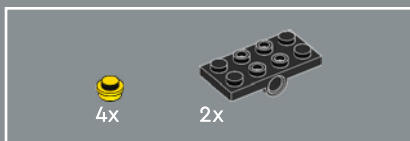
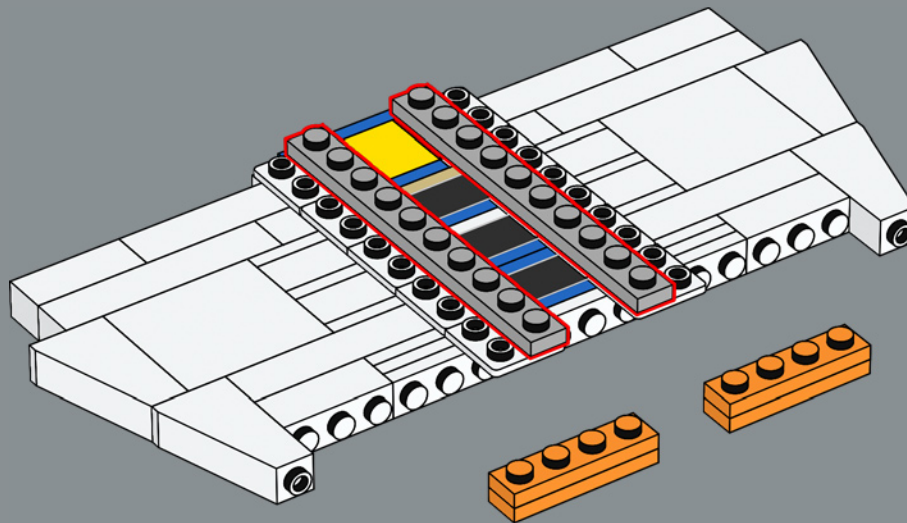

164

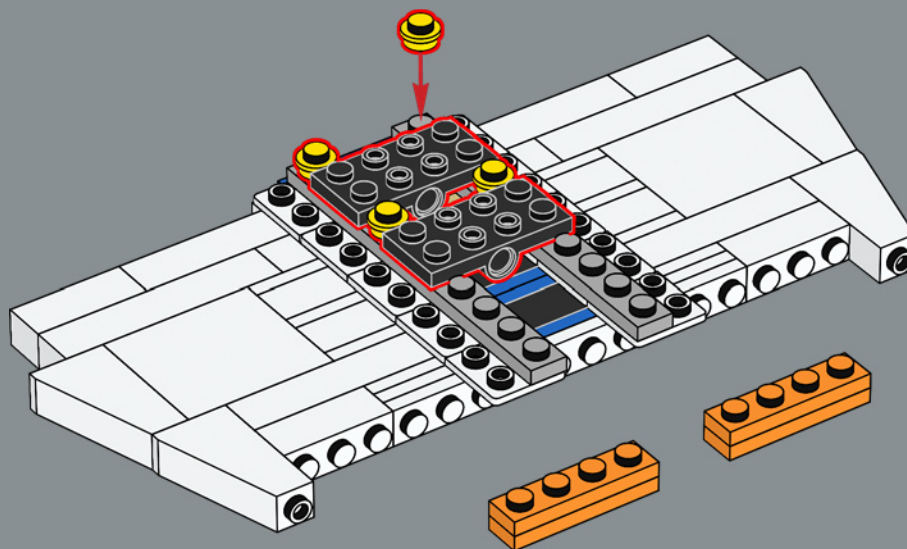



165

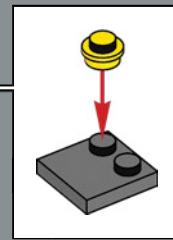
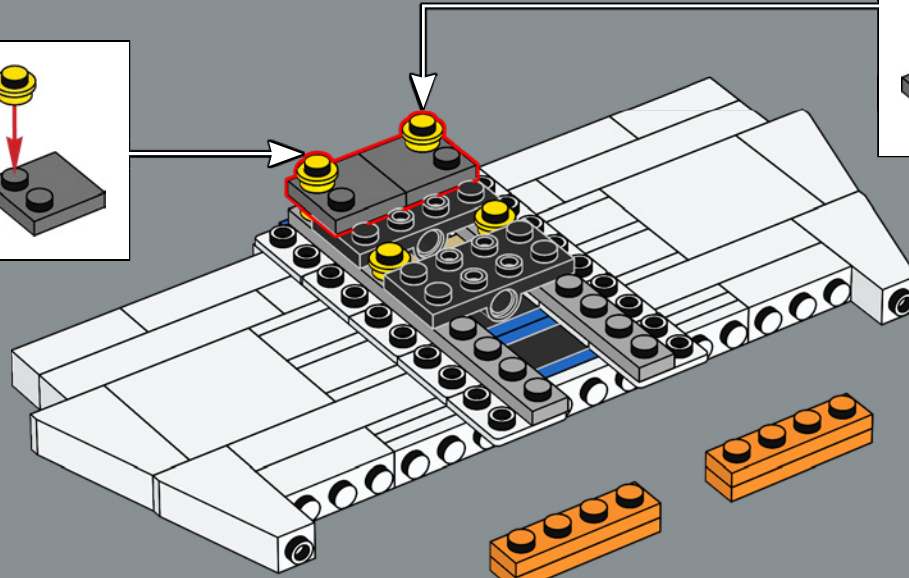
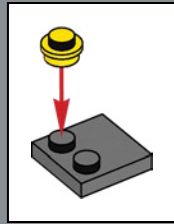

166

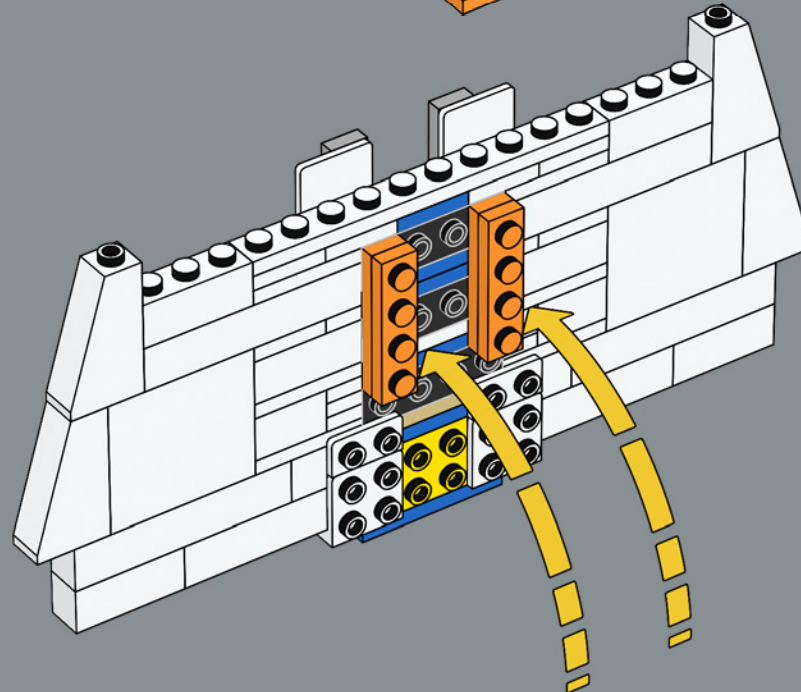



167

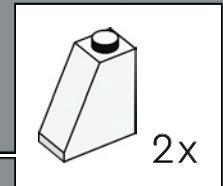
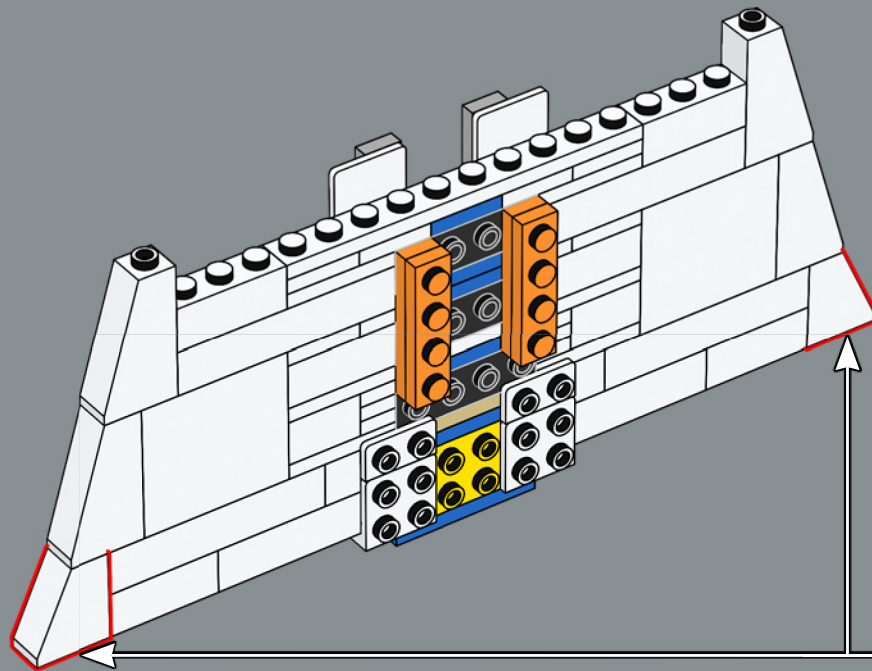

168

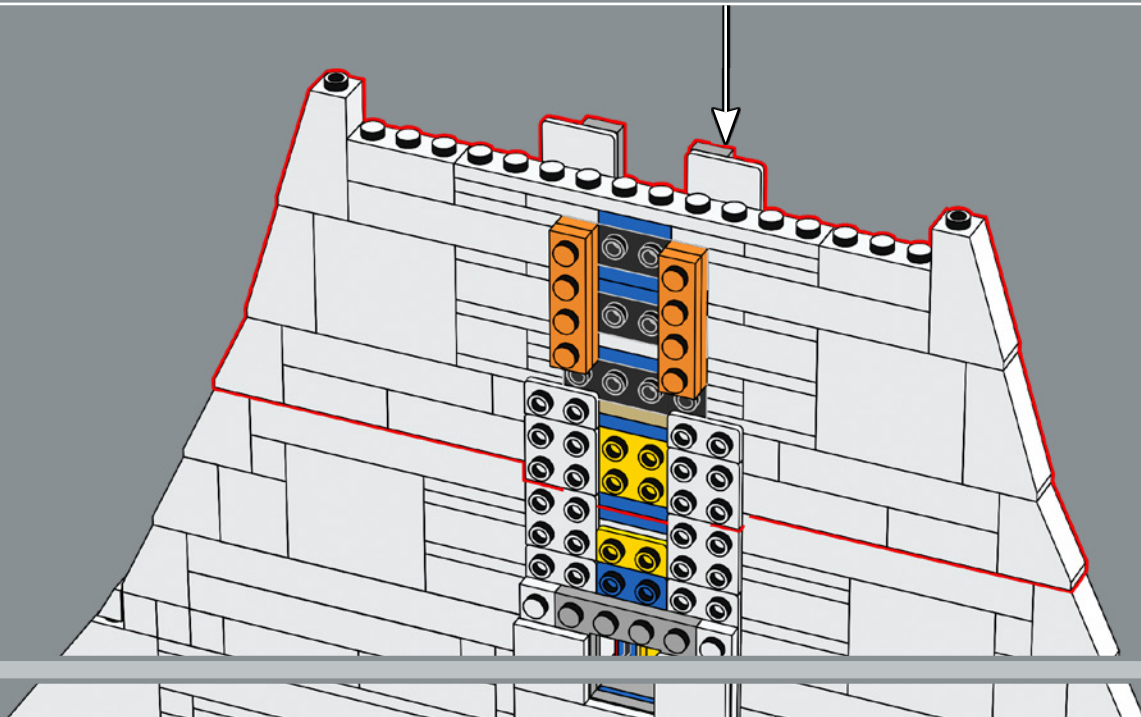

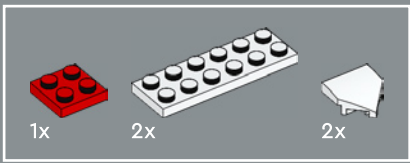

169

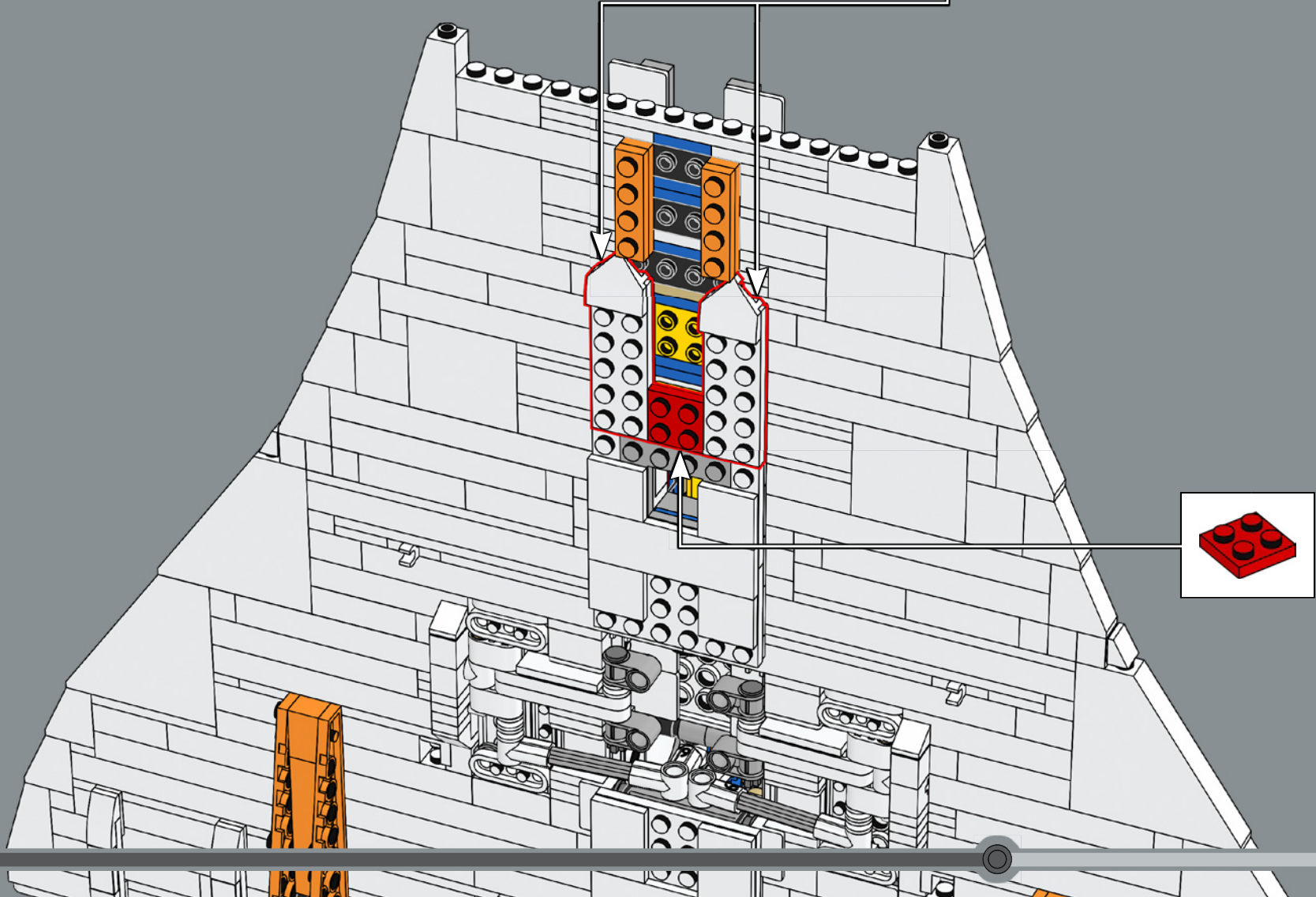
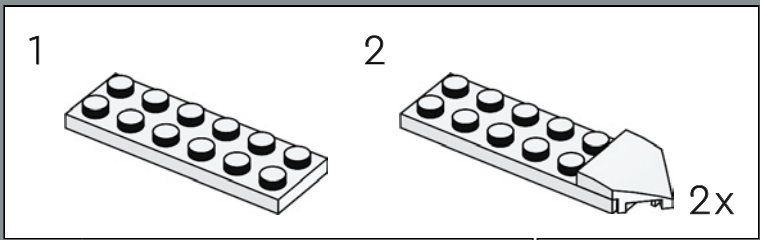

170

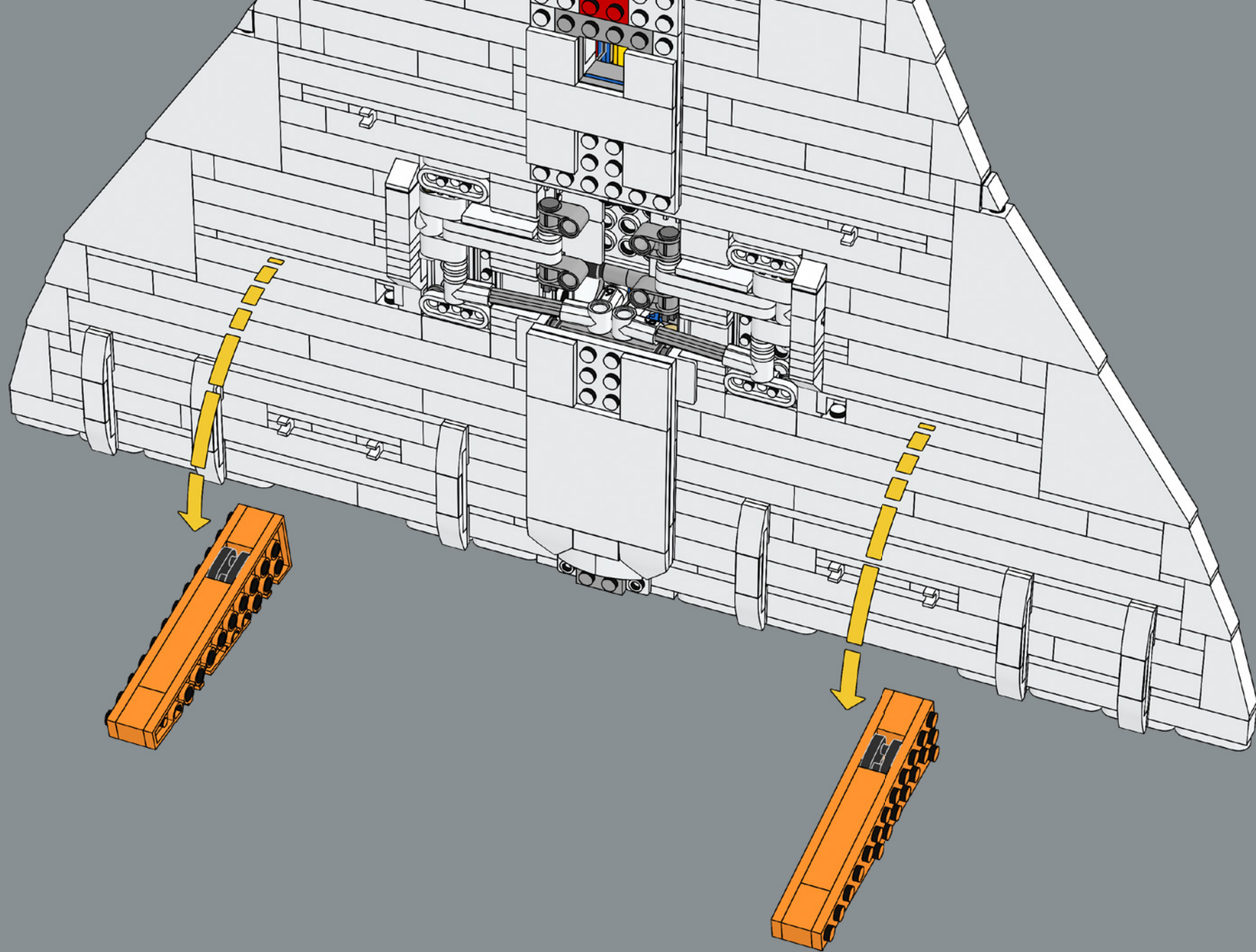

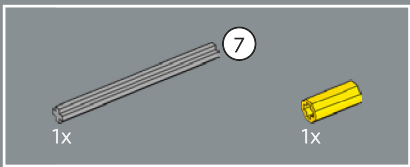

171

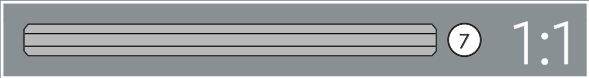
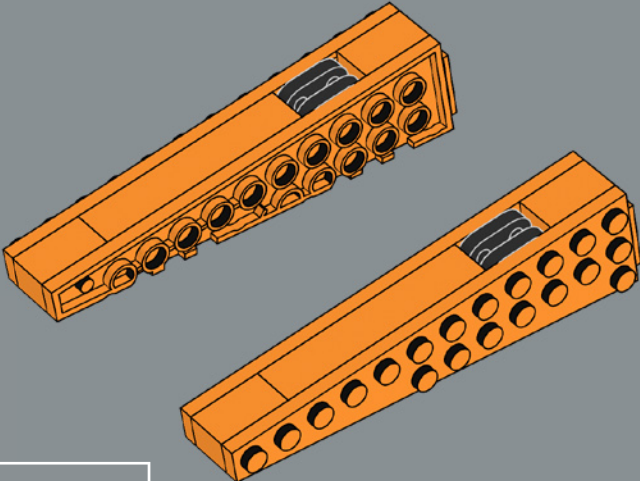
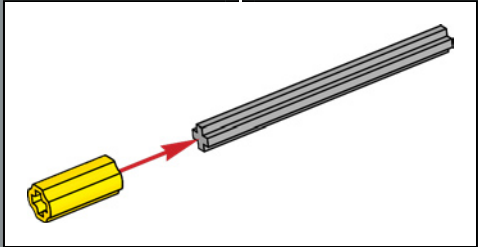
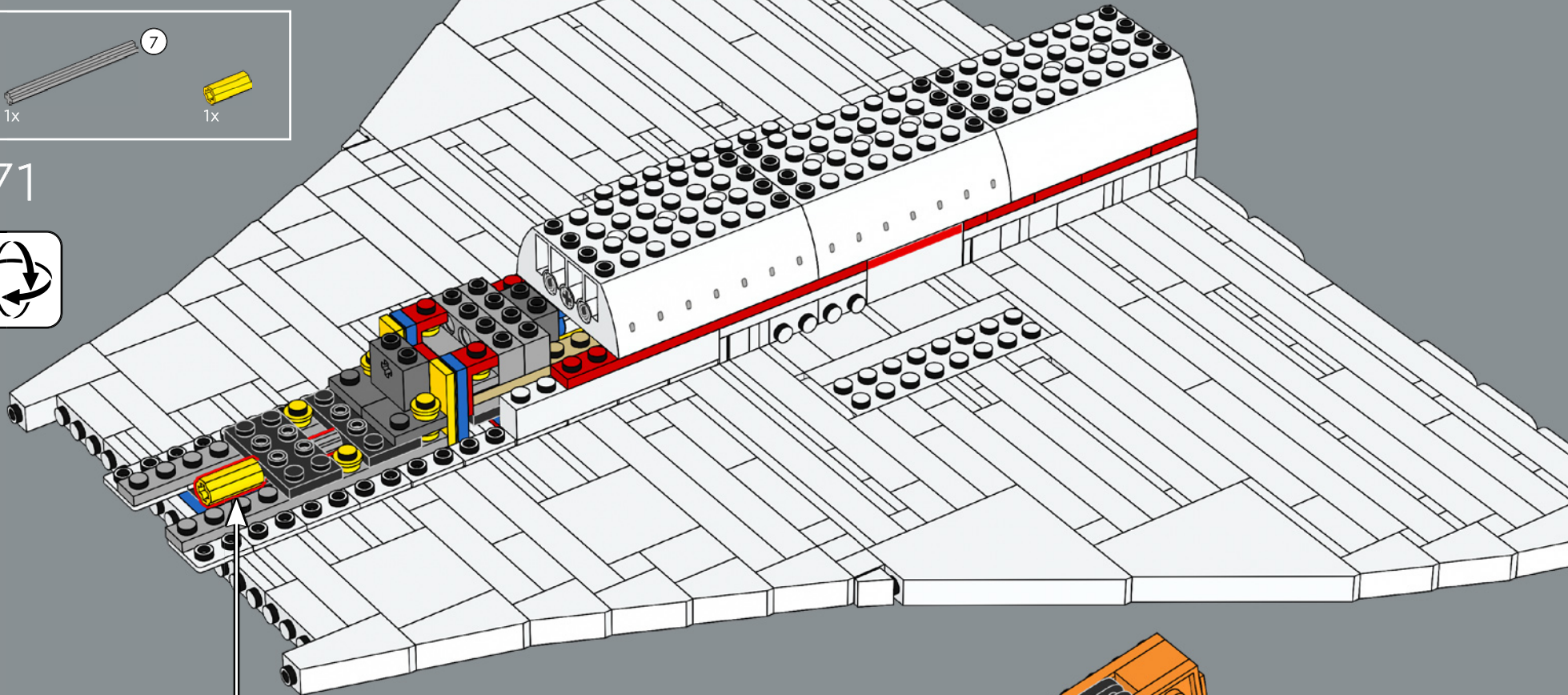

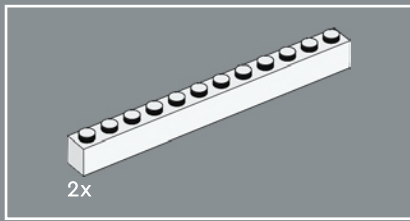

172

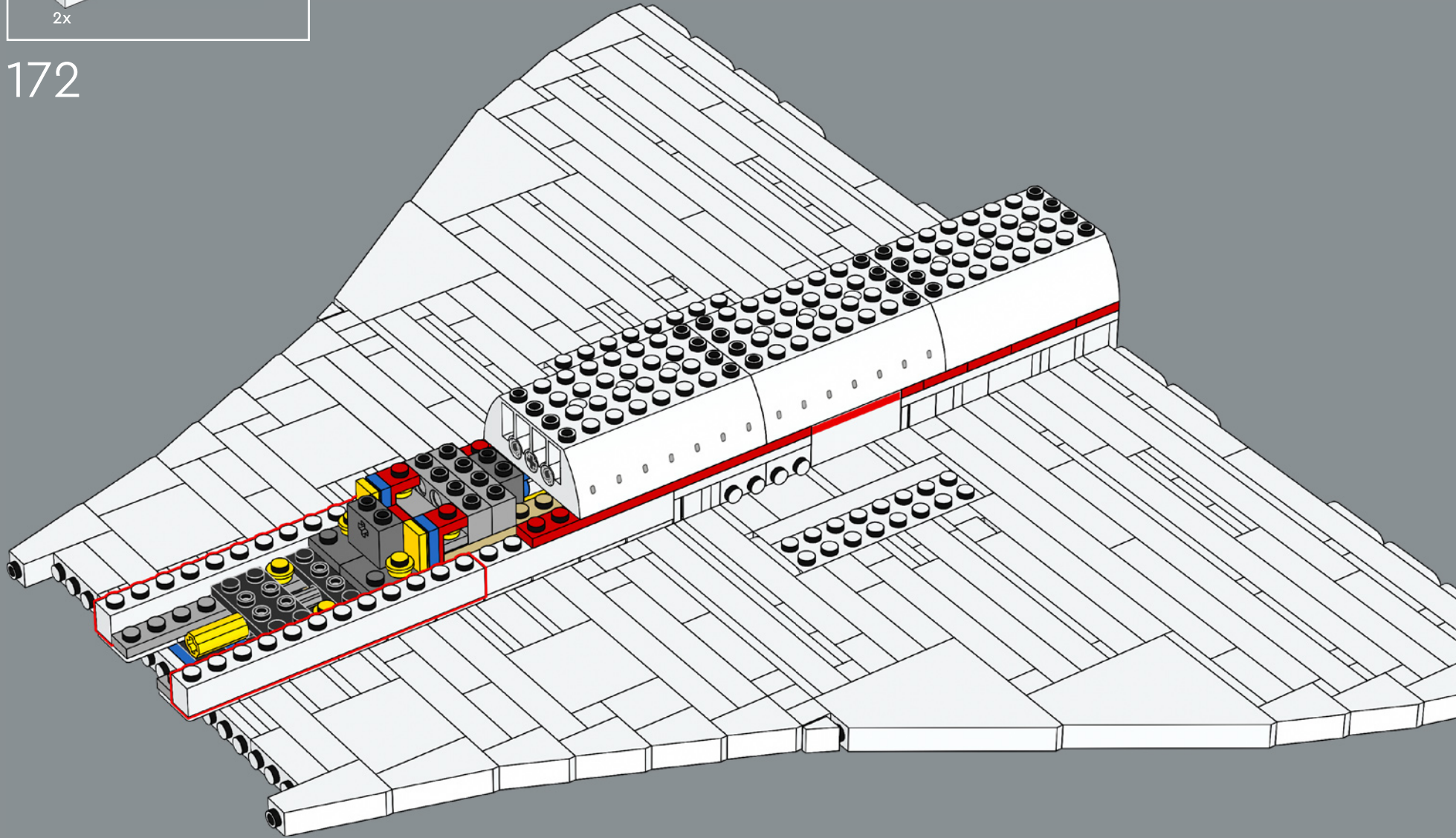

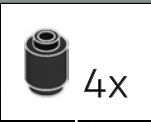
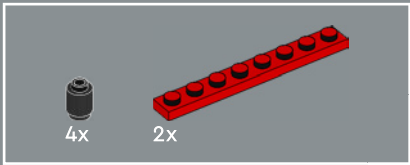

173

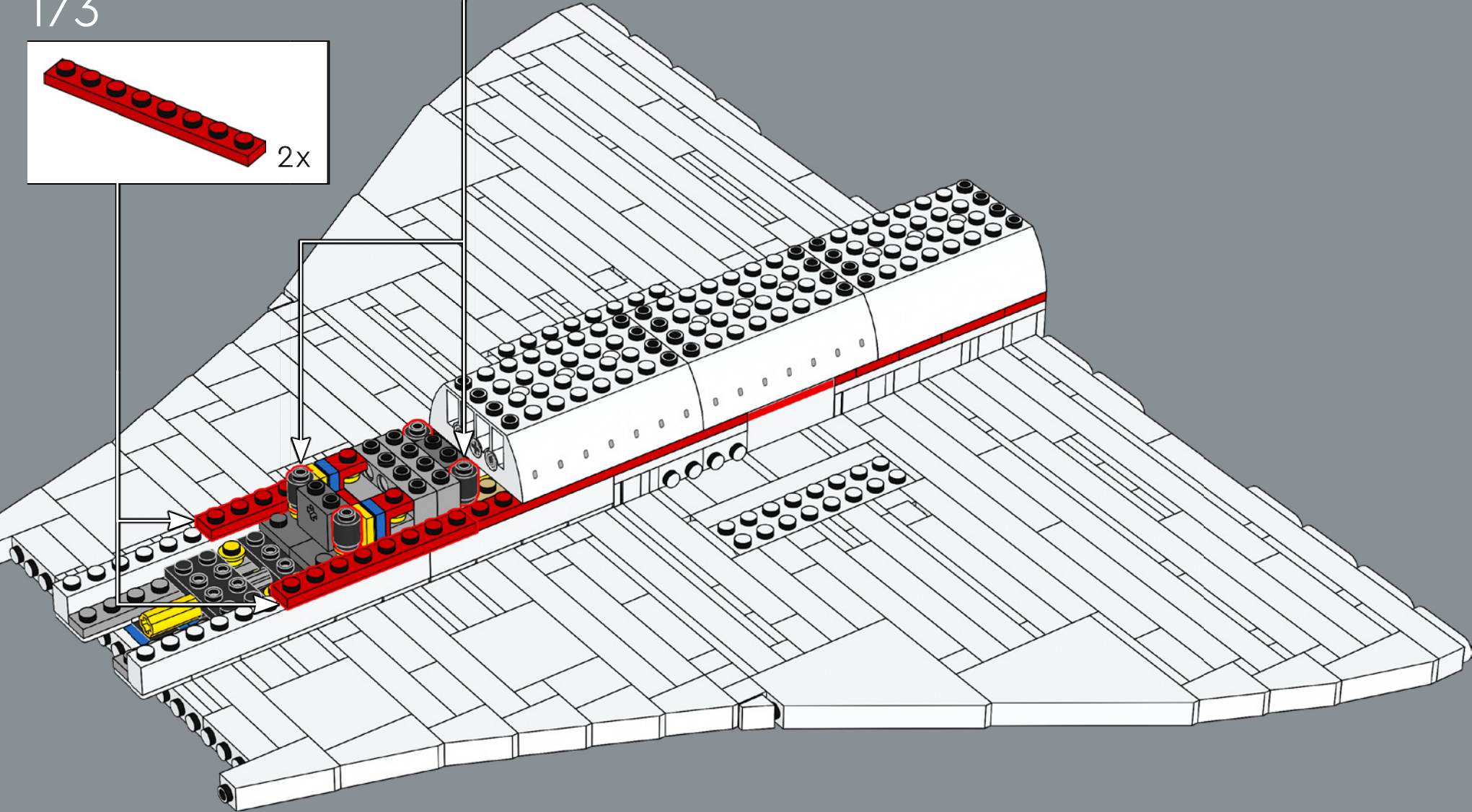
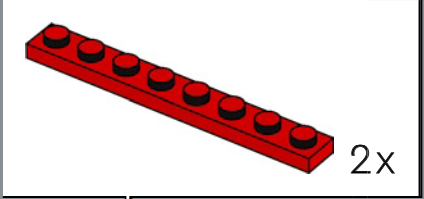

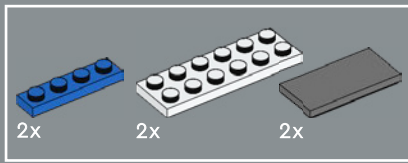

174

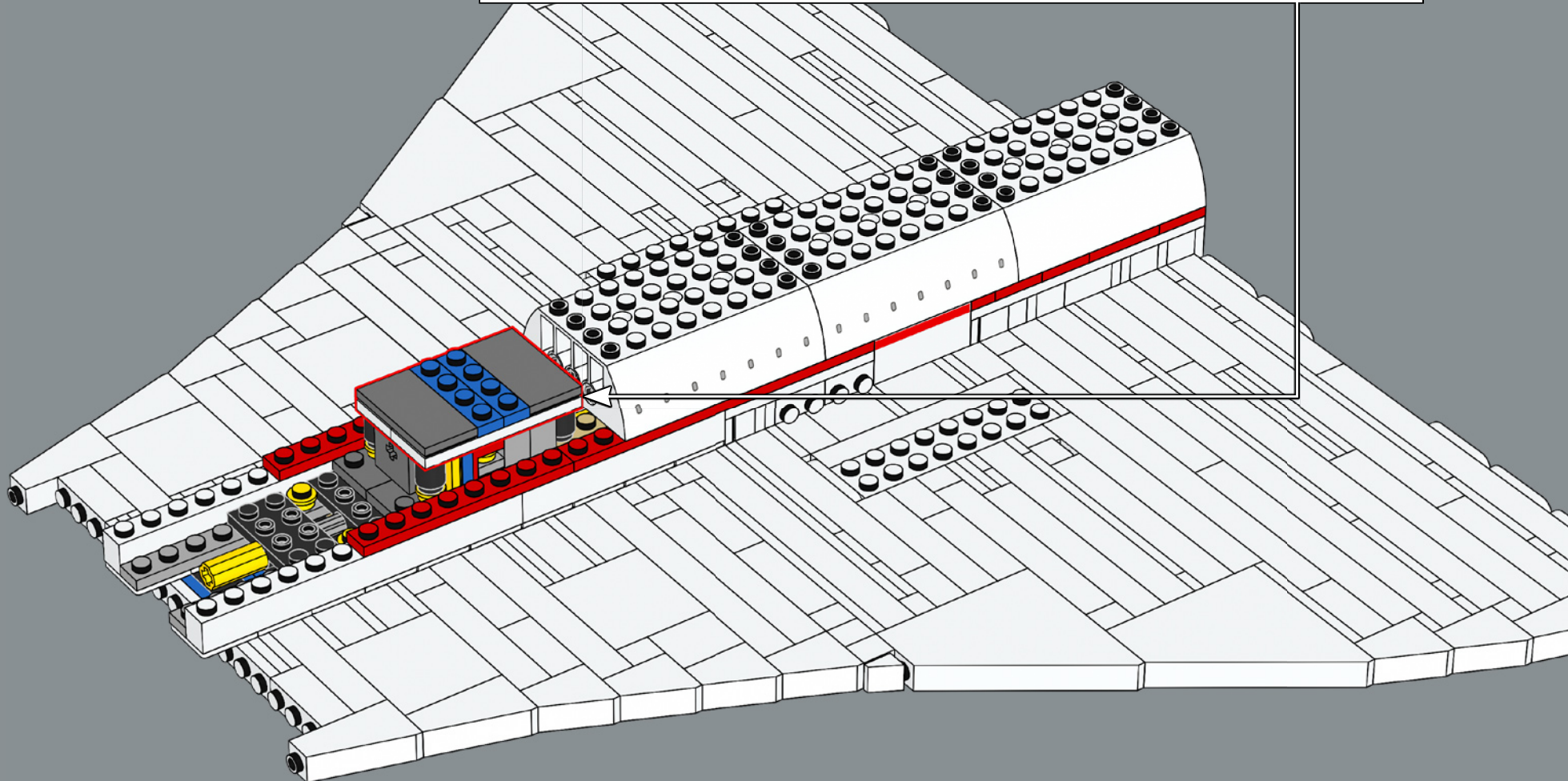
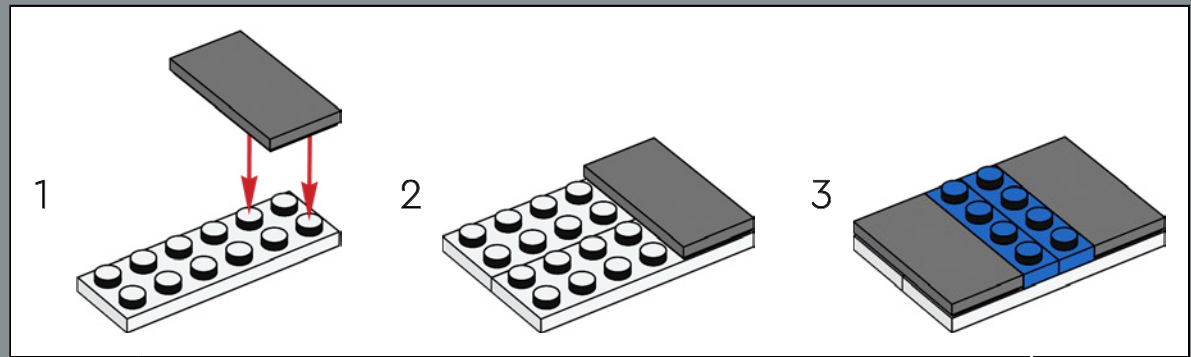

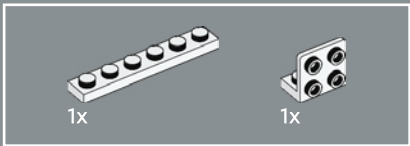
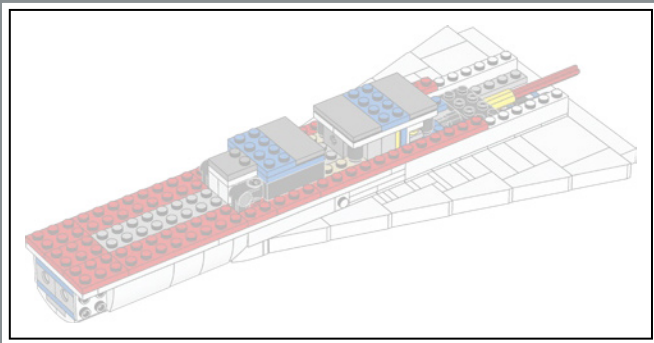

175

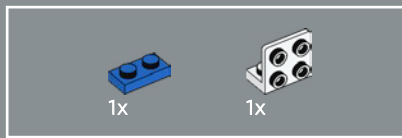
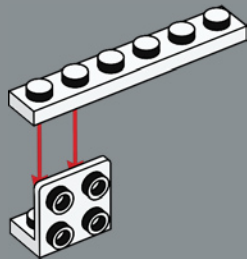

176

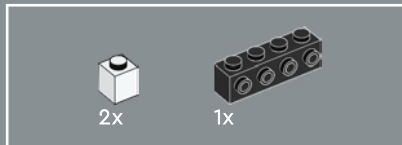
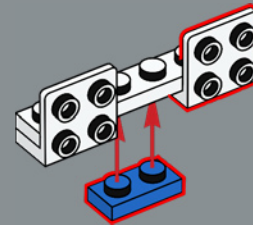

177

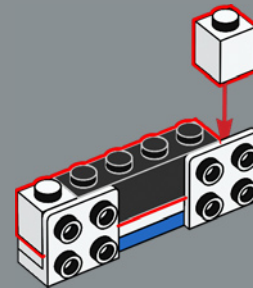

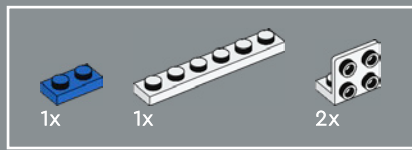

178

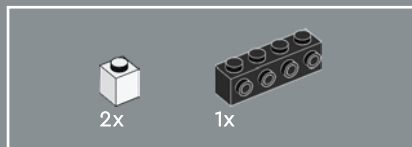
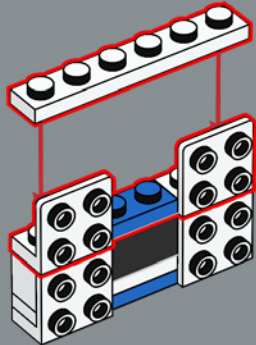

179

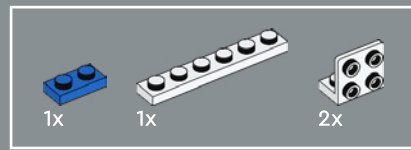
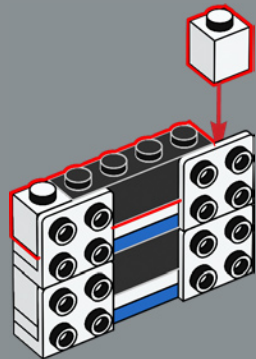

180

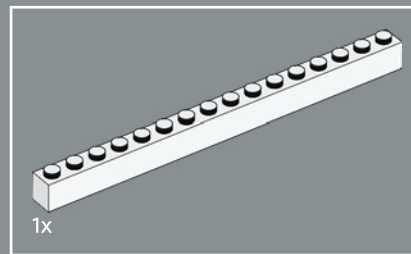
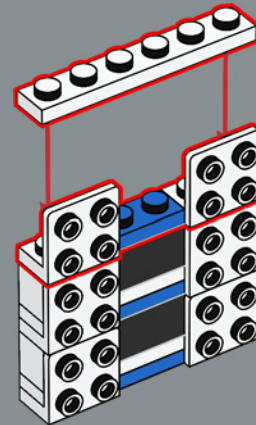

181

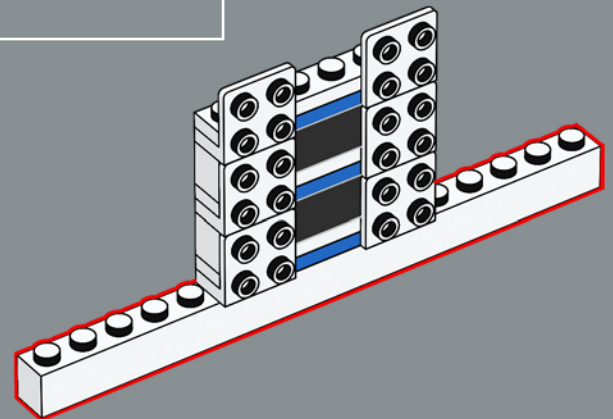

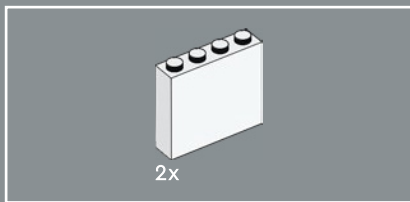

182

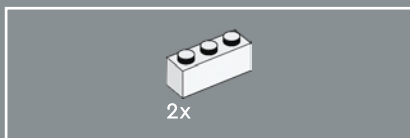
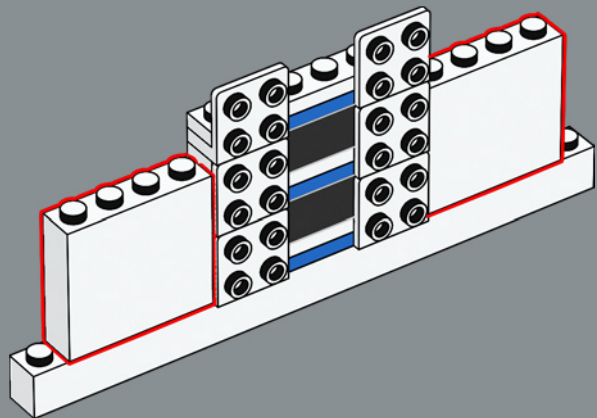

183

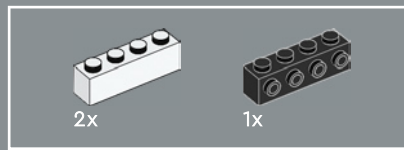
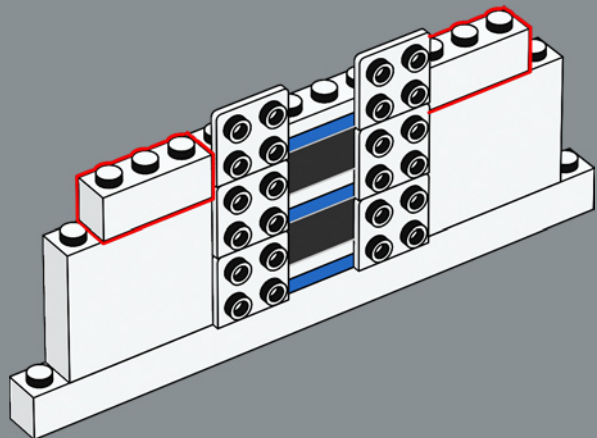

184

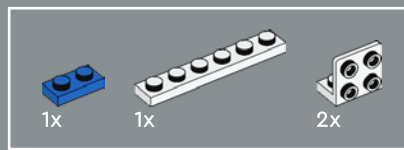
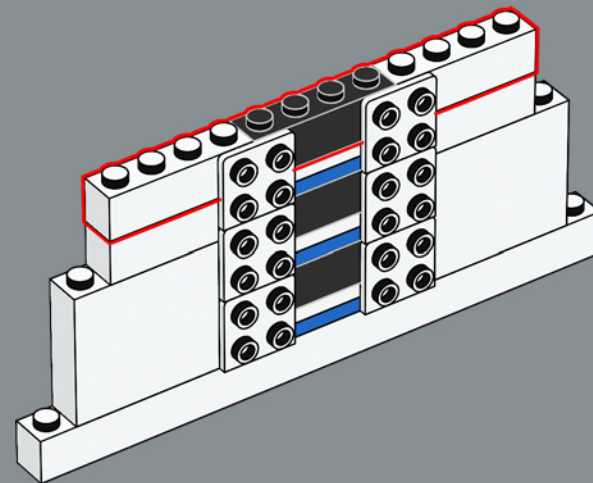

185

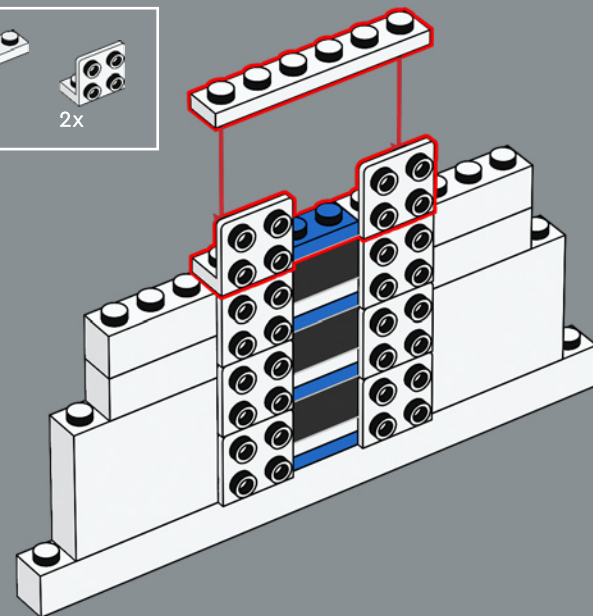

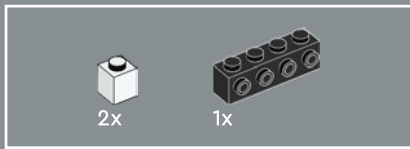

186

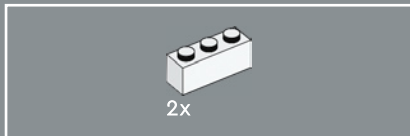
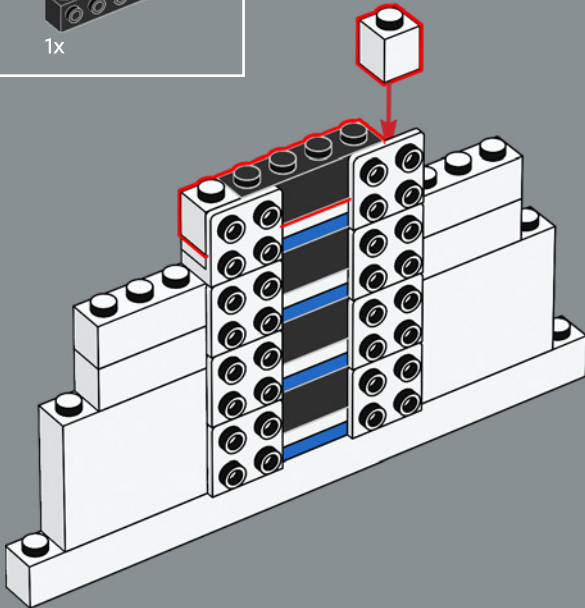

187

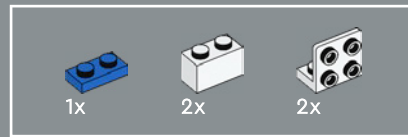
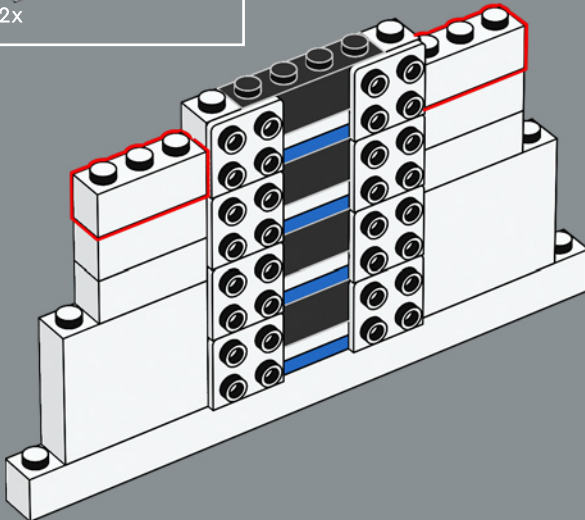

188

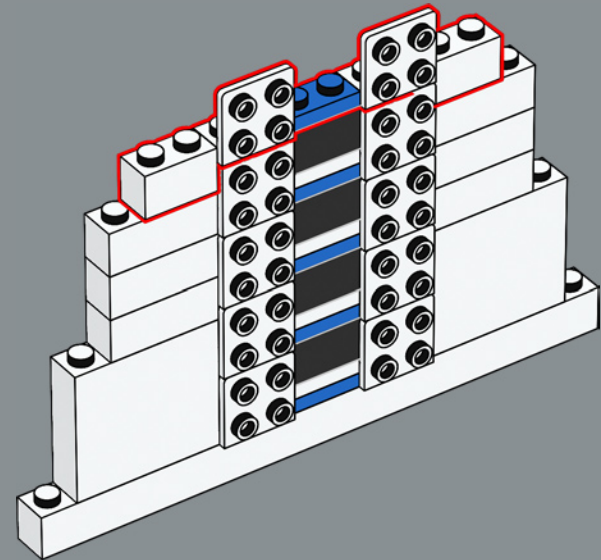

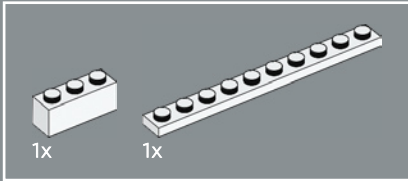
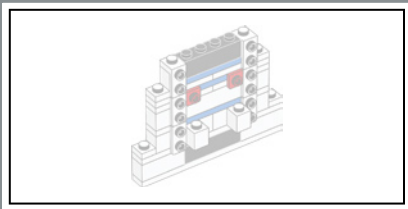

189

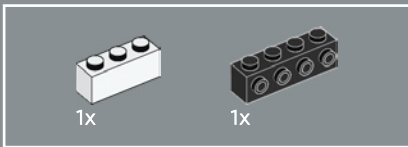
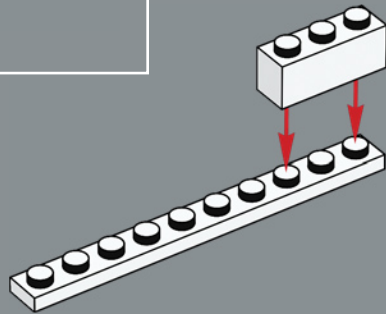

190

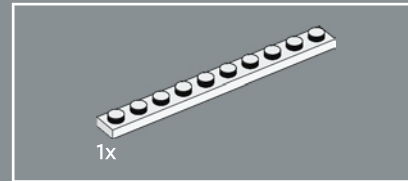
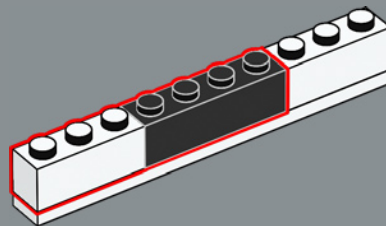

191

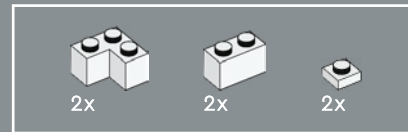
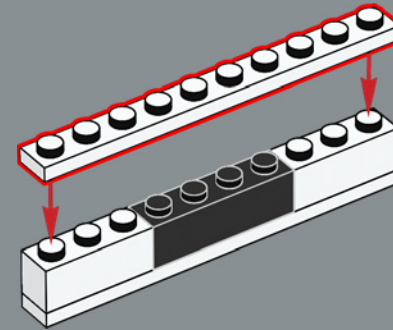

192

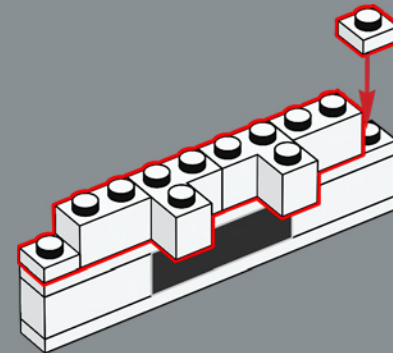

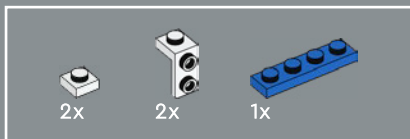

193

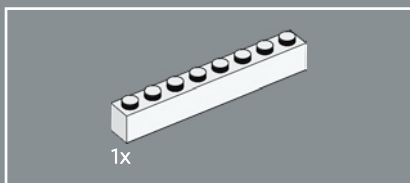
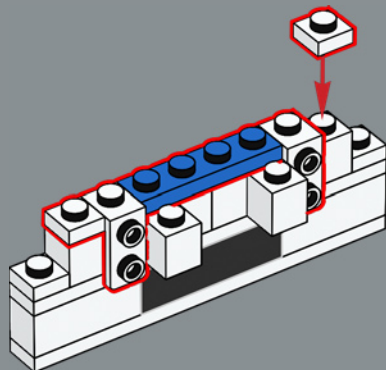

194

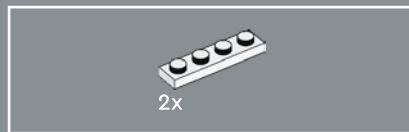
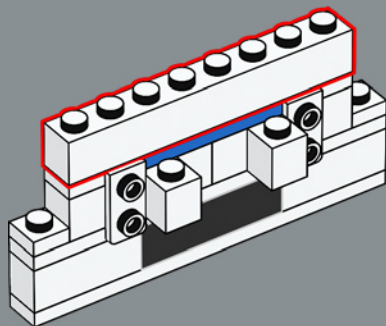

195

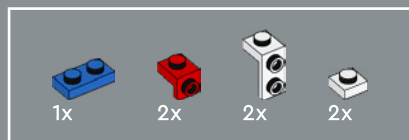
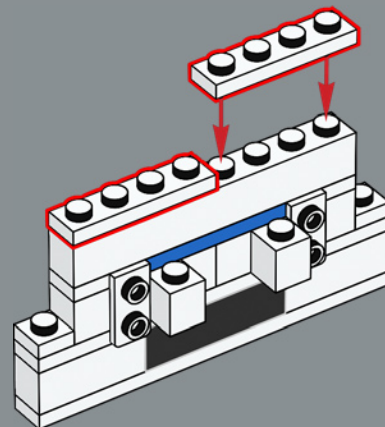

196

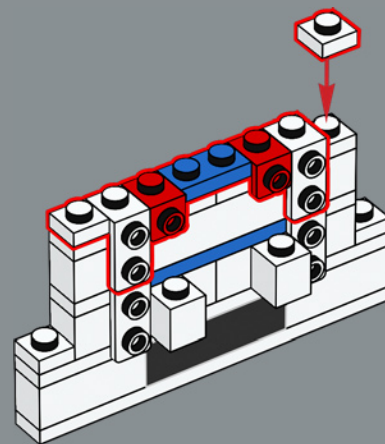

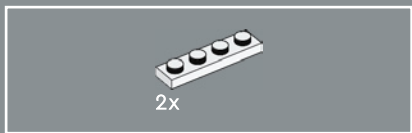

197

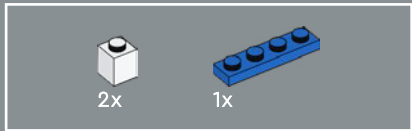
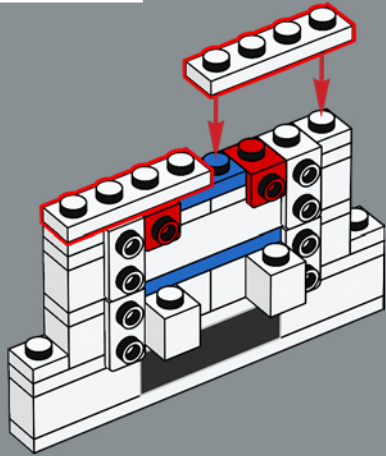

198

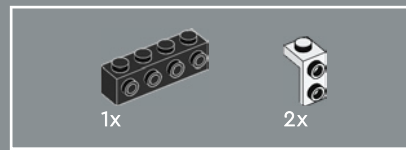
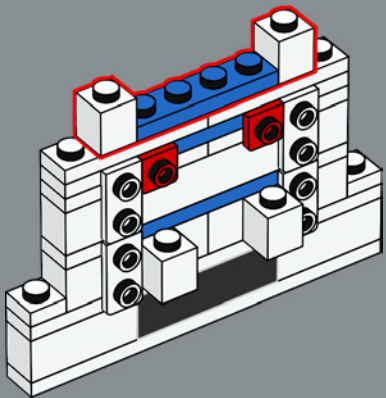

199

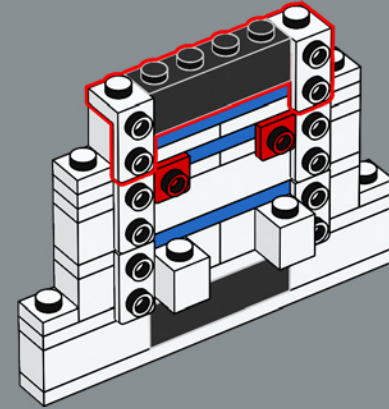

200

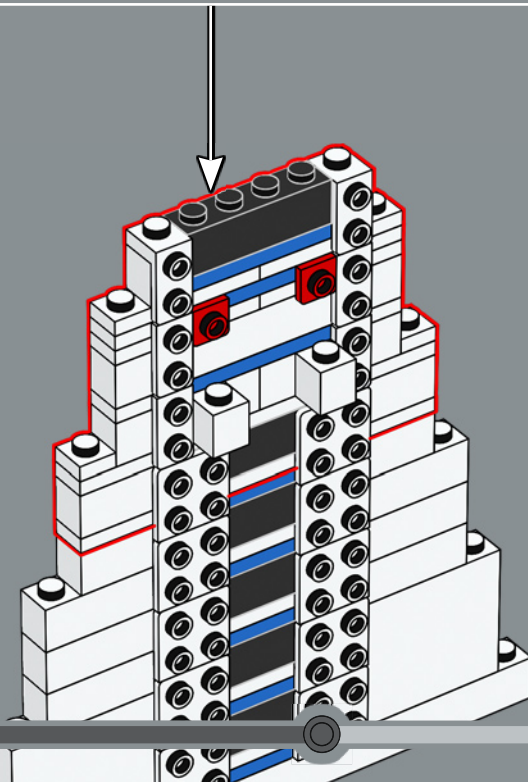

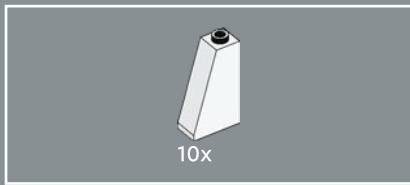

201

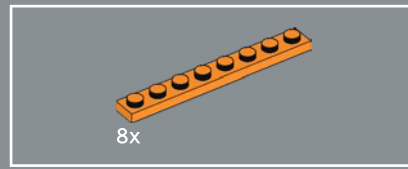
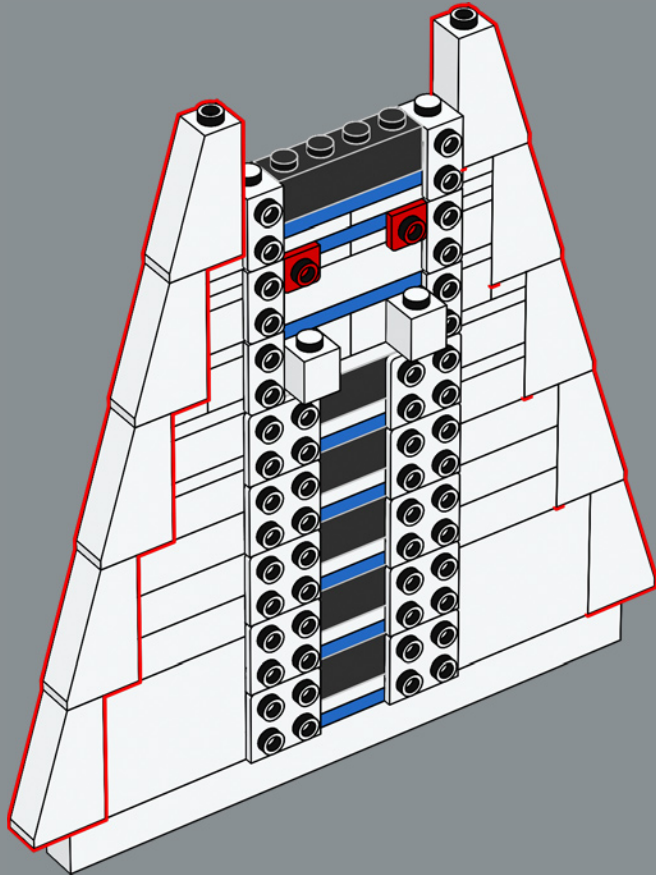

202

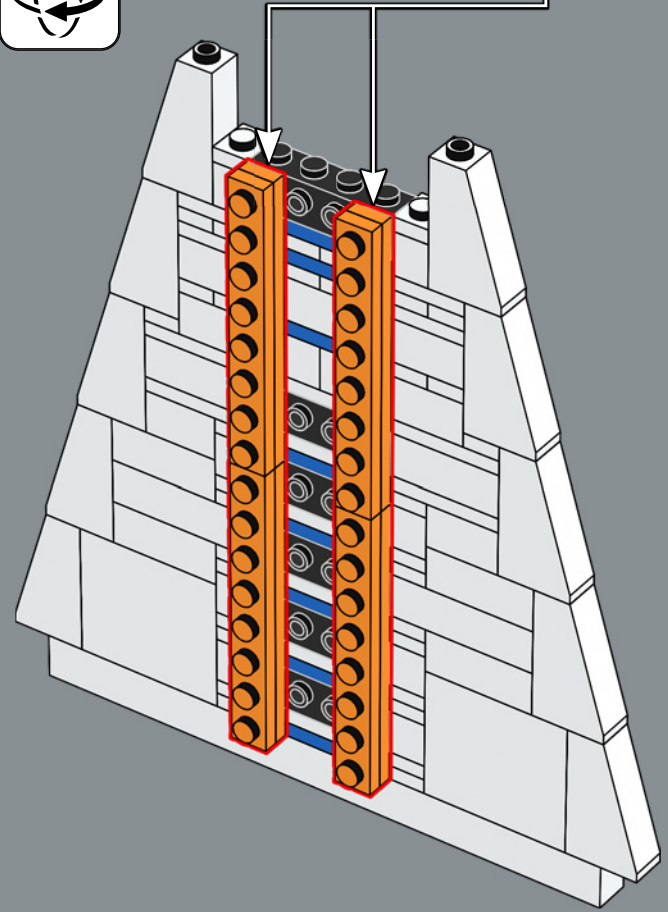
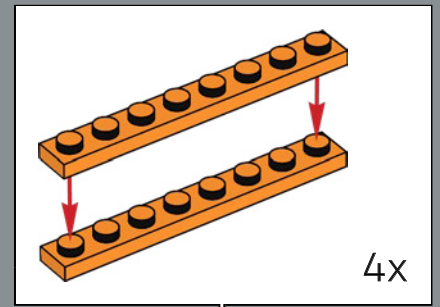

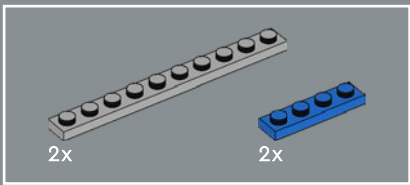

203

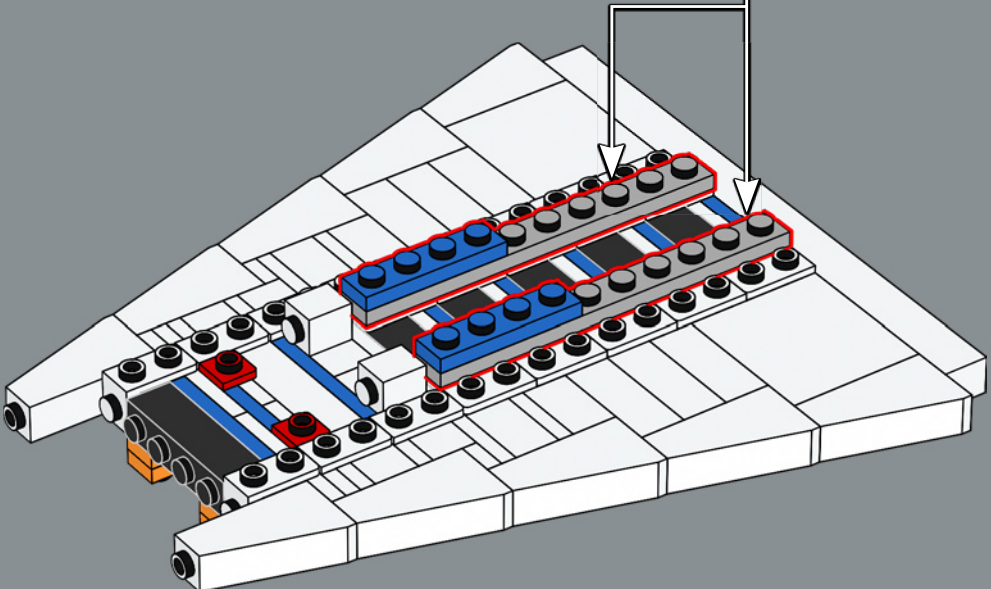
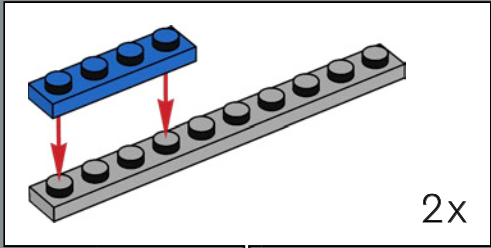

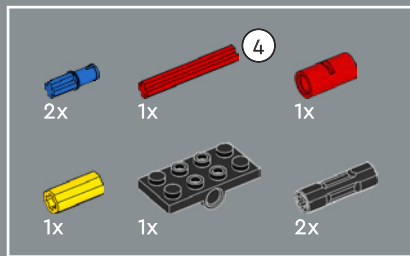

204

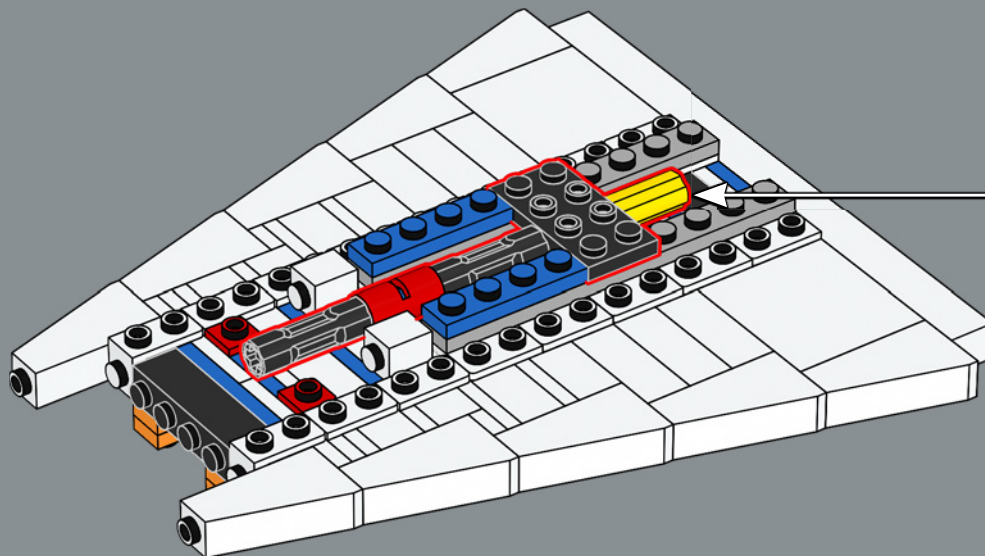
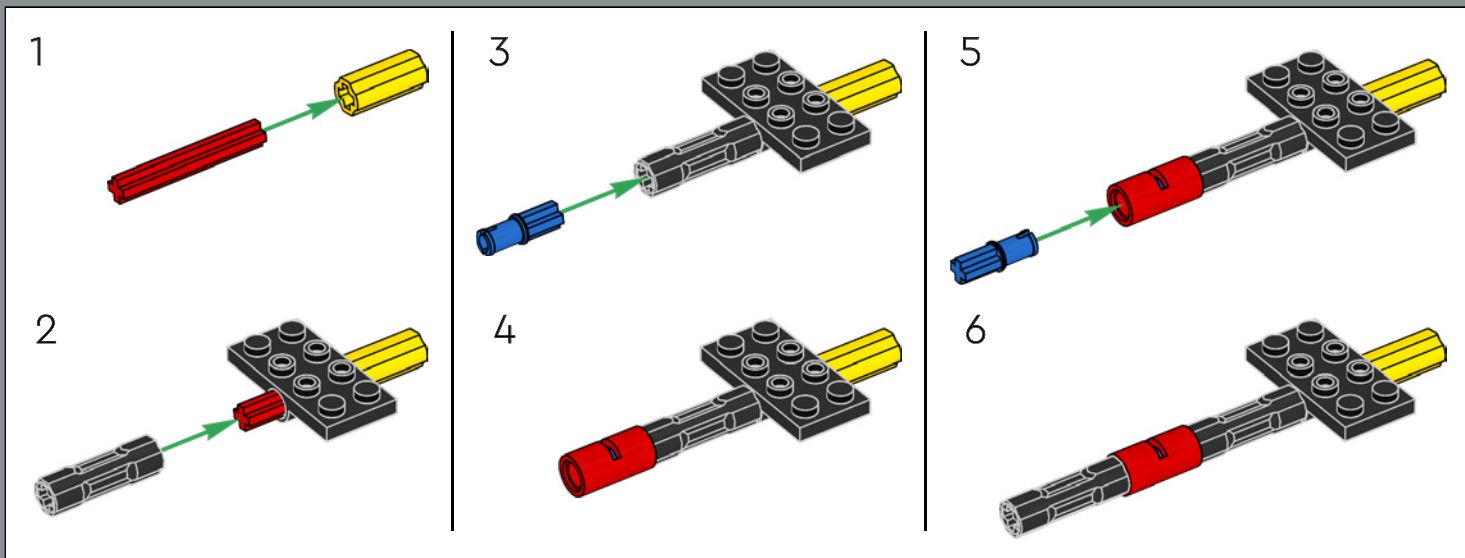

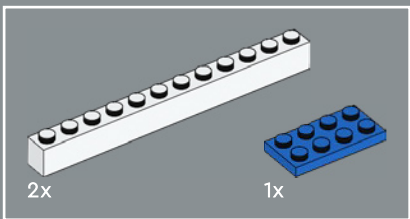

这个离合器是一个出色的解决方案，
可确保你的模型着陆时前后起落架
保持同步！

205

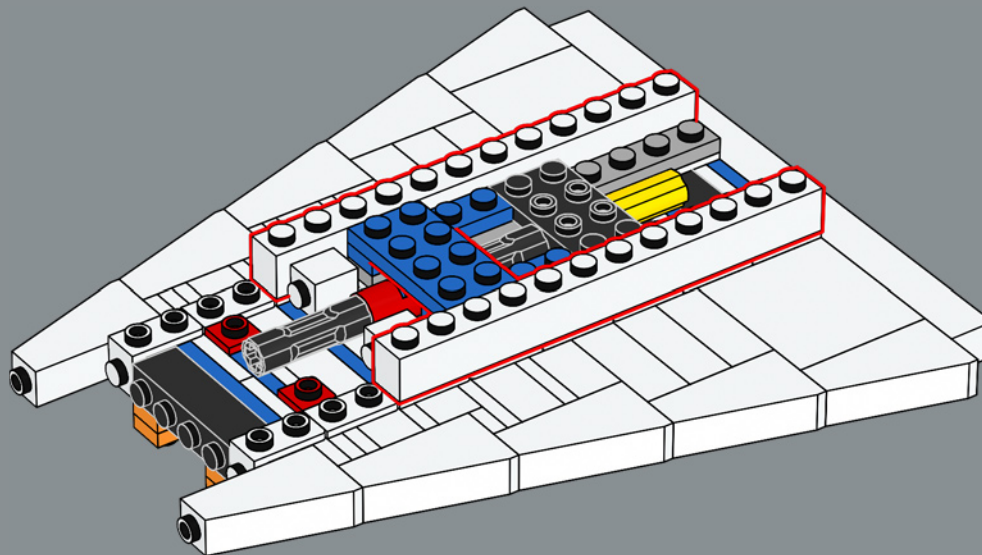

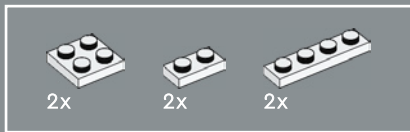

206

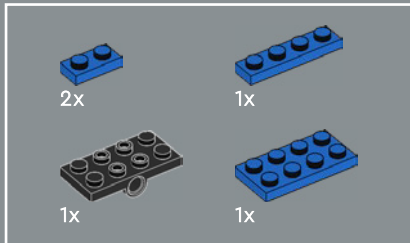
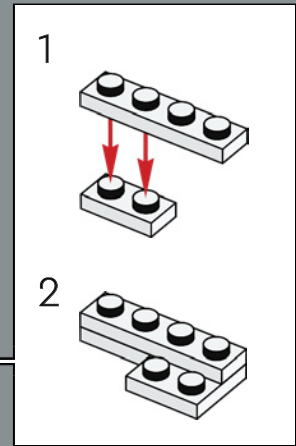
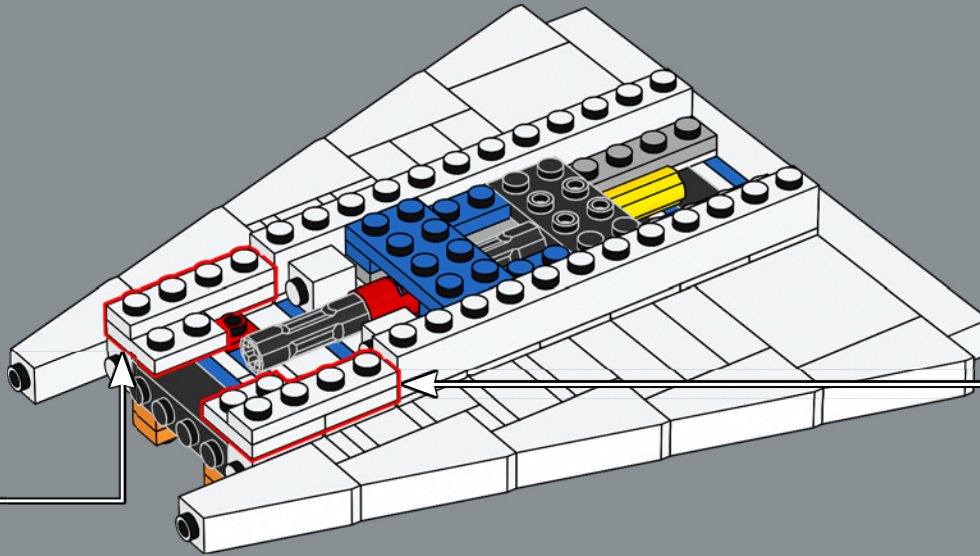
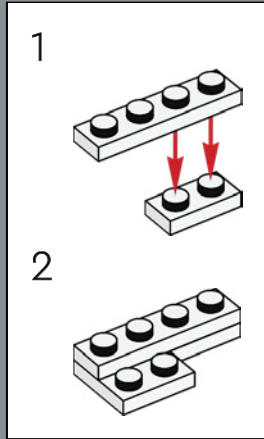

207

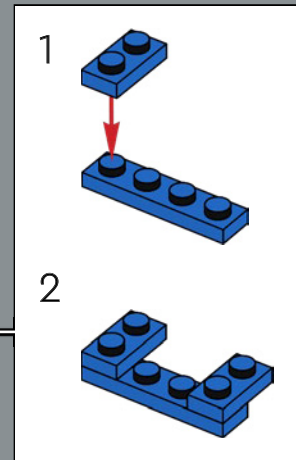
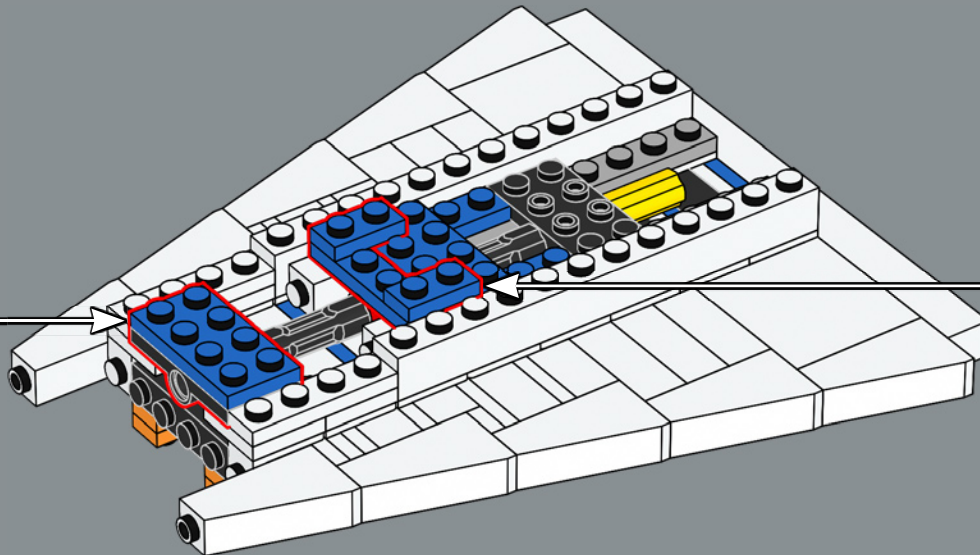
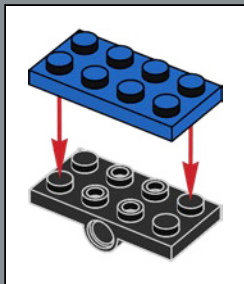

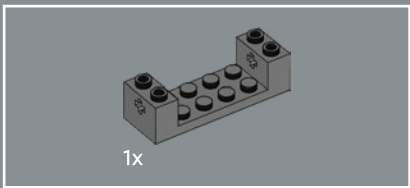

208

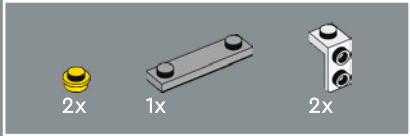
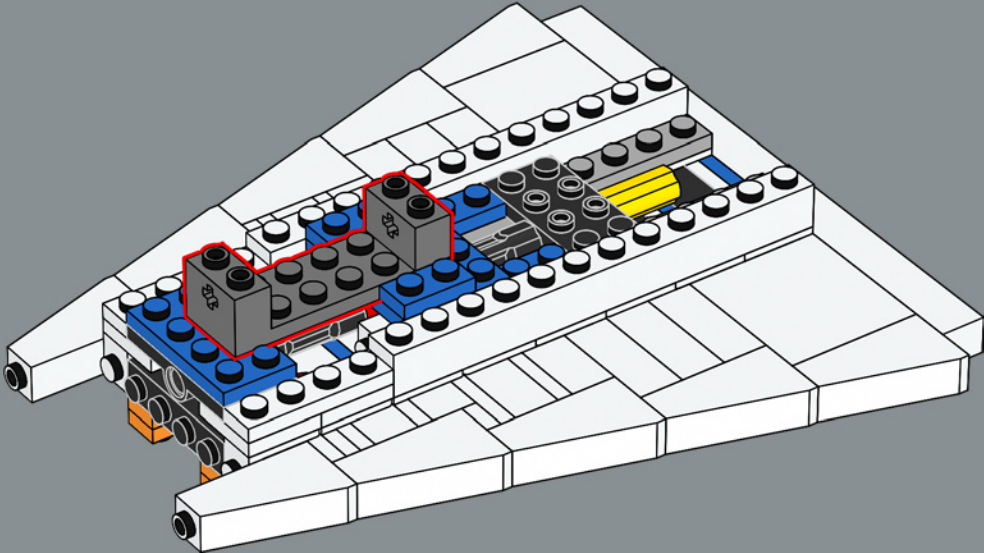

209

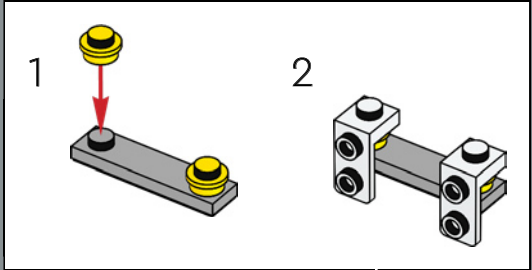
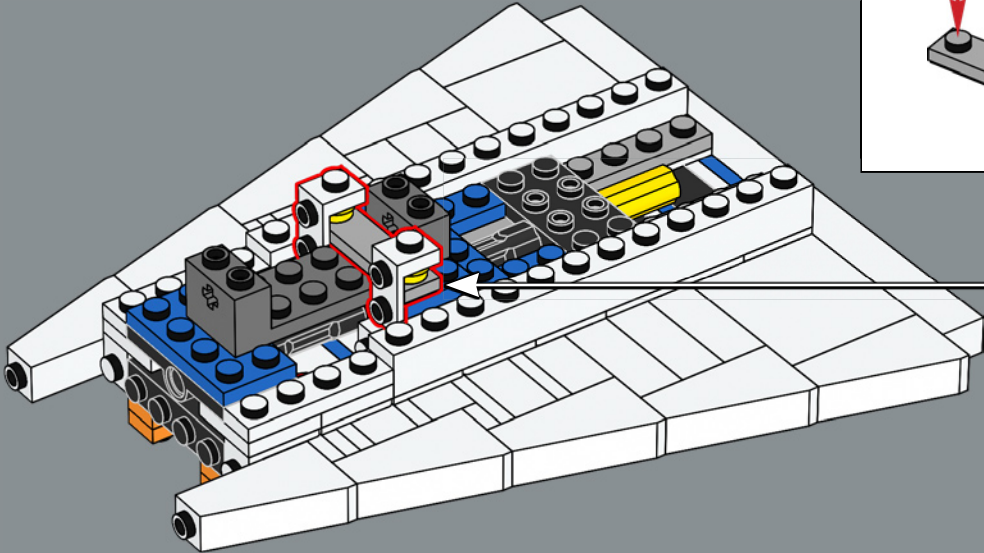

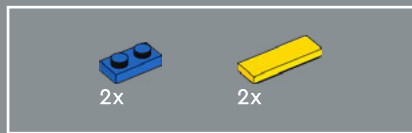

210

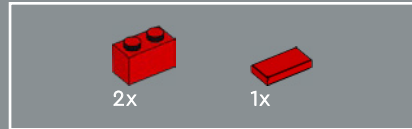
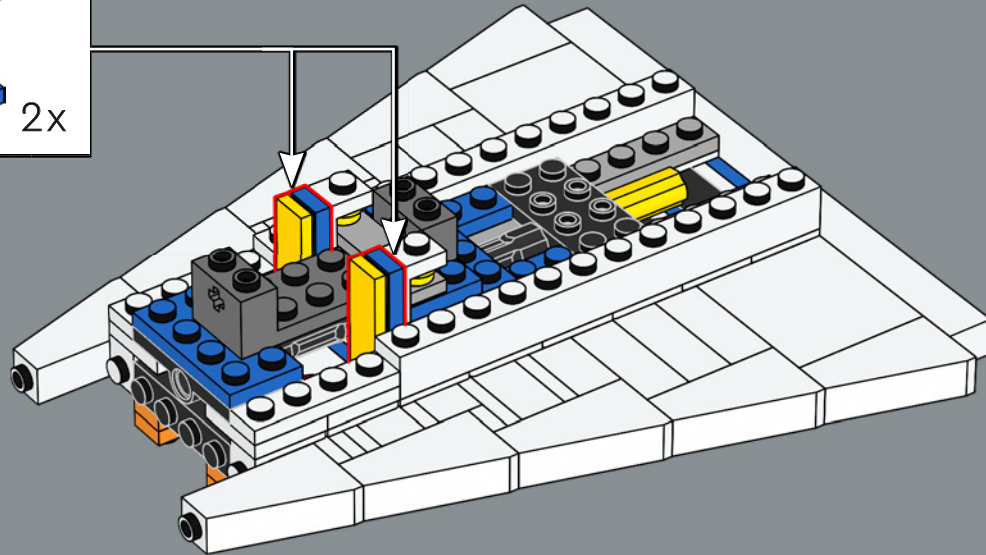
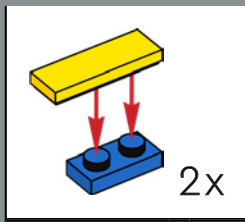

211

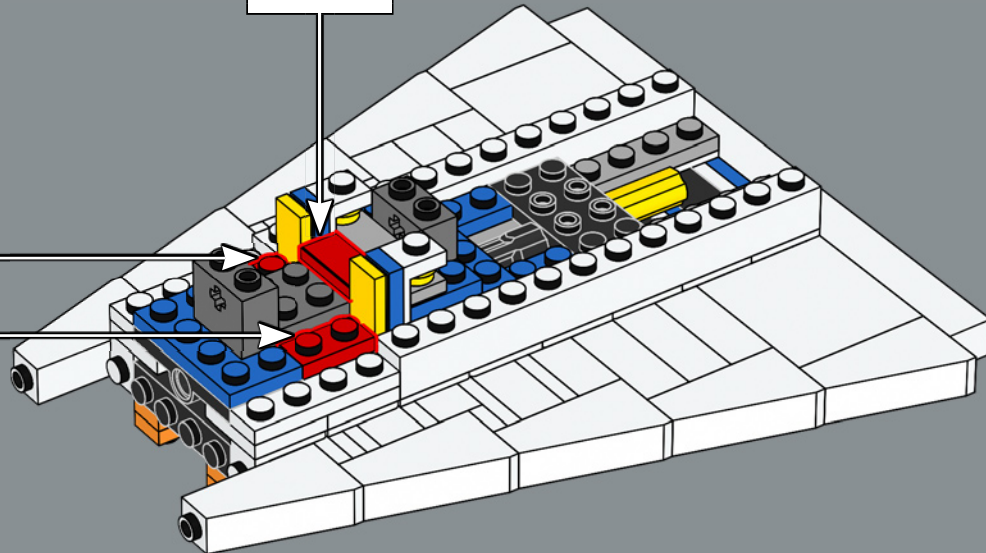
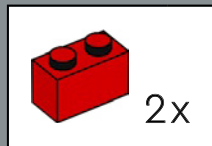
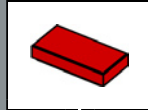

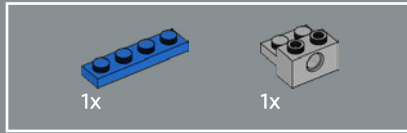
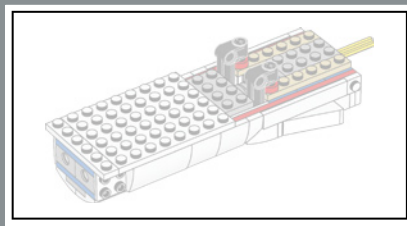

212

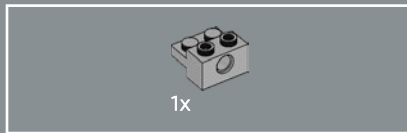
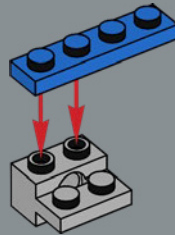

213

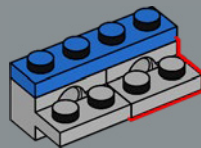

214

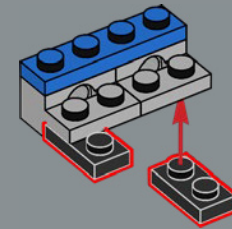

215

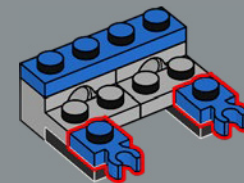

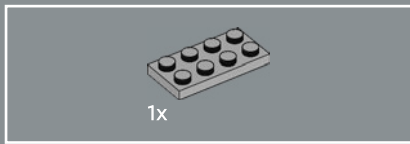

216

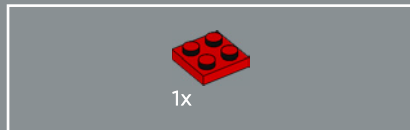
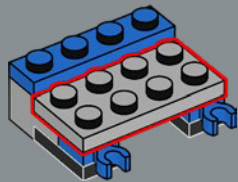

217

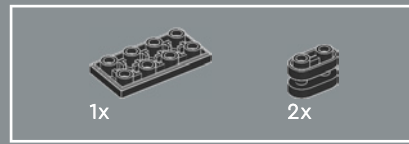
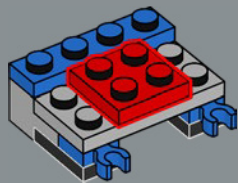

218

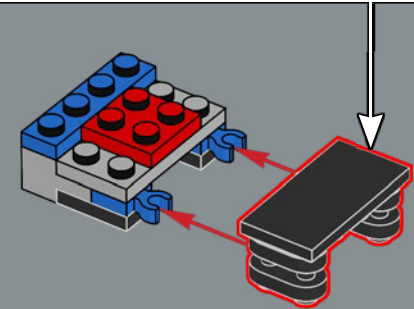
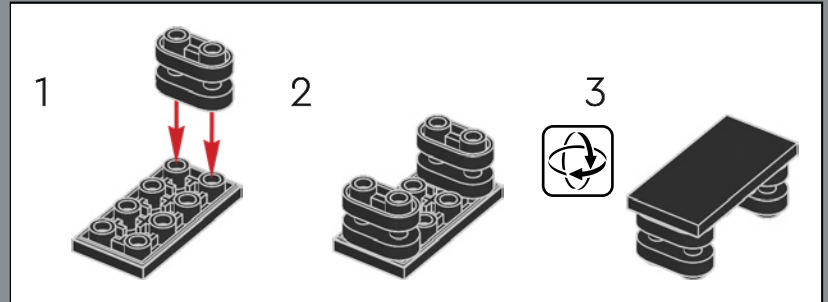



219

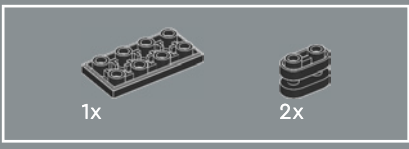
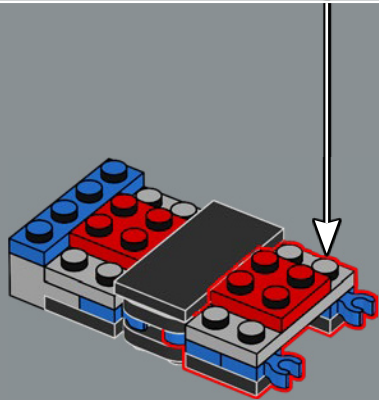
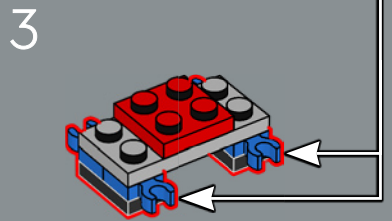
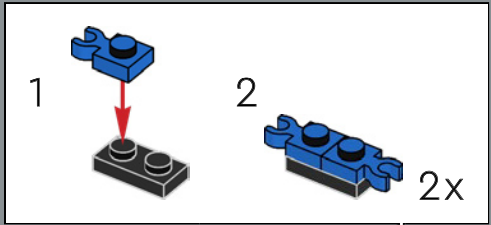
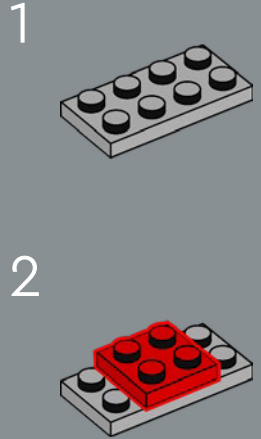

220

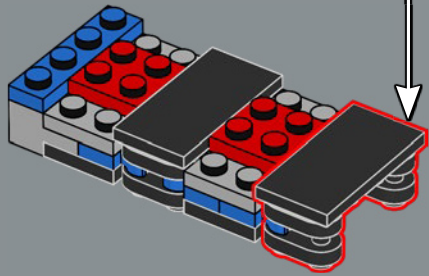
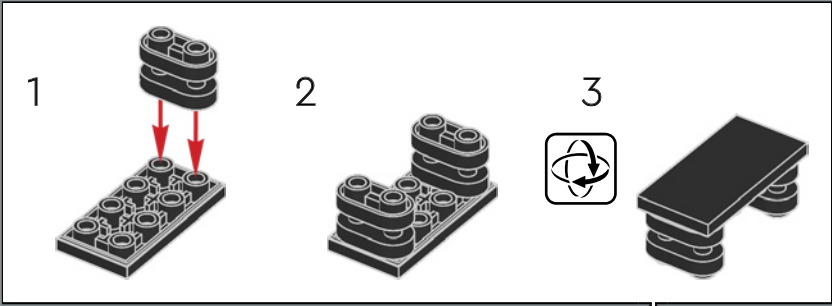

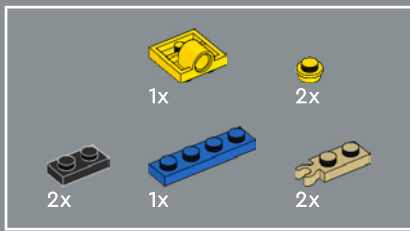

221

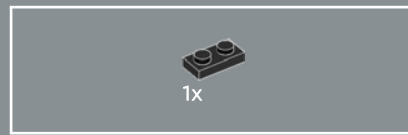
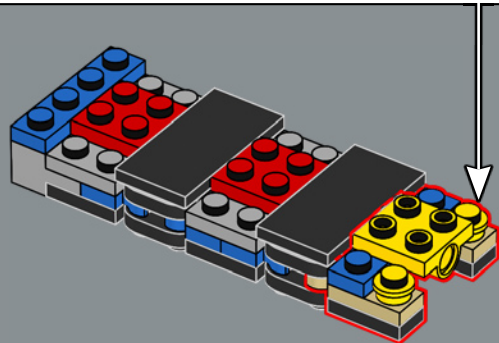
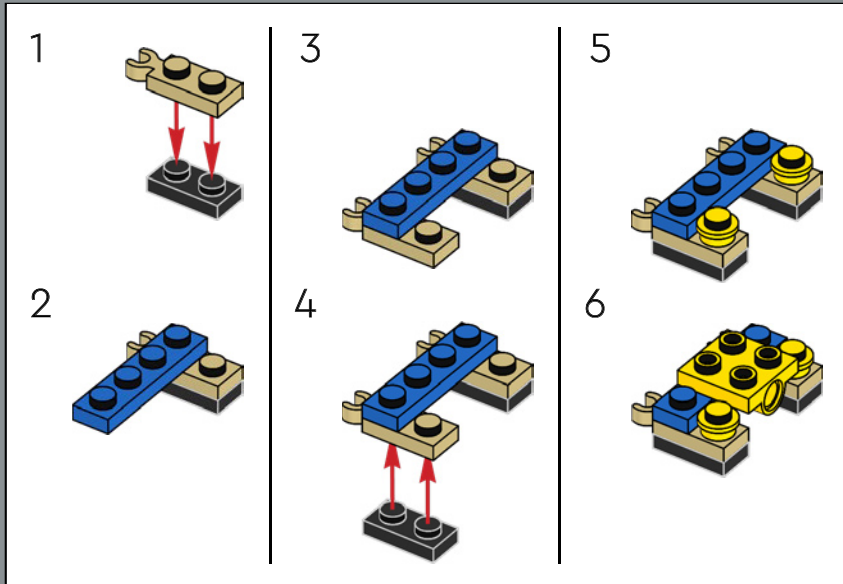

222

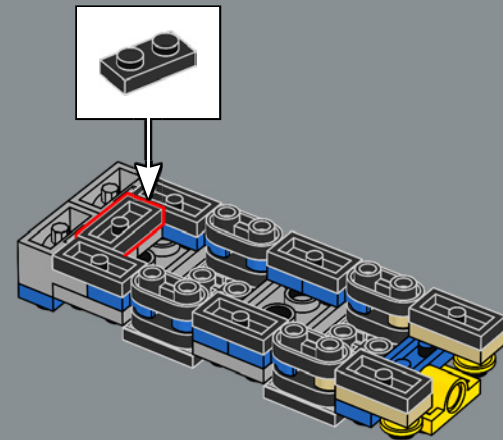

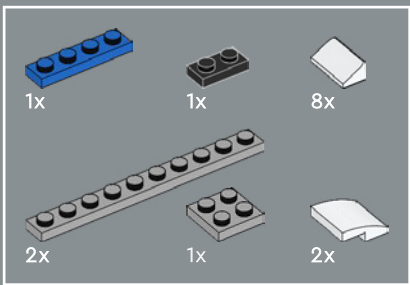

223

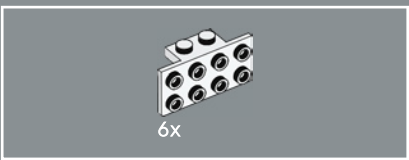
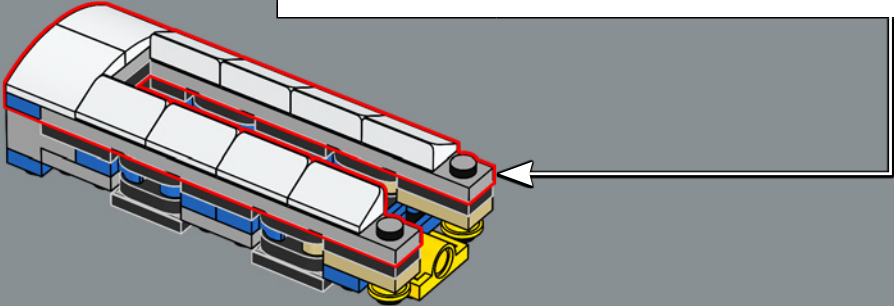
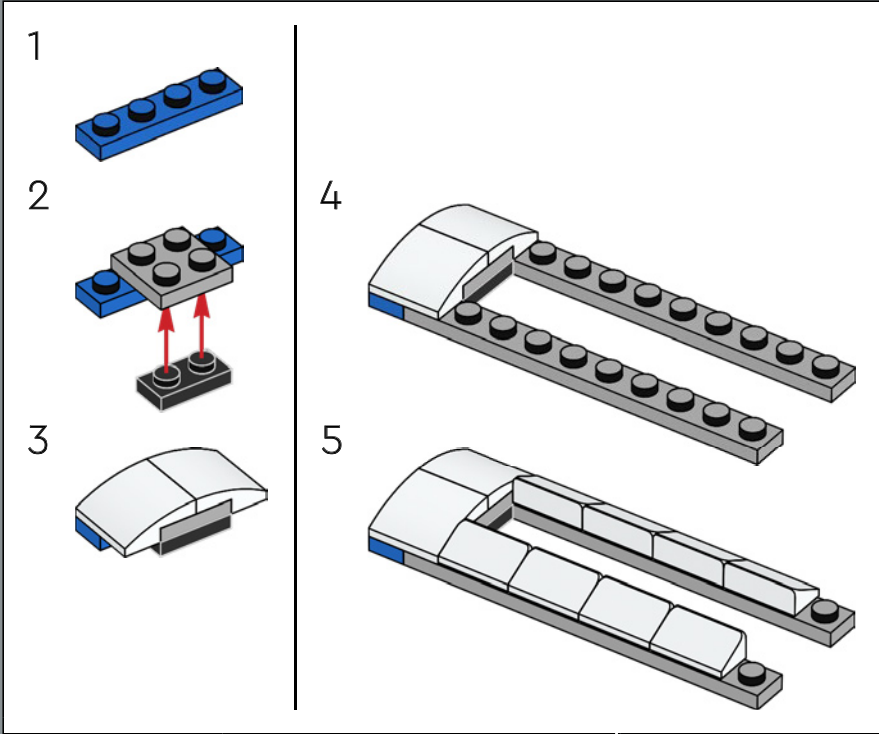

224

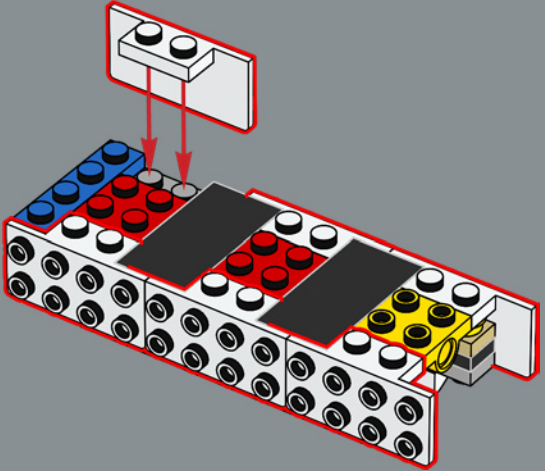

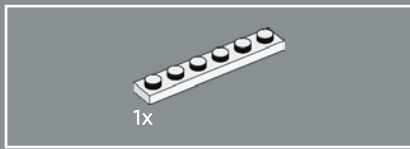

225

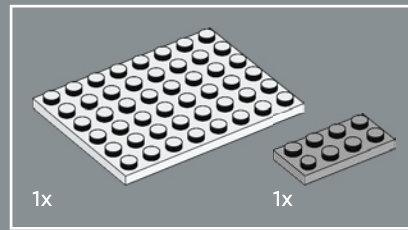
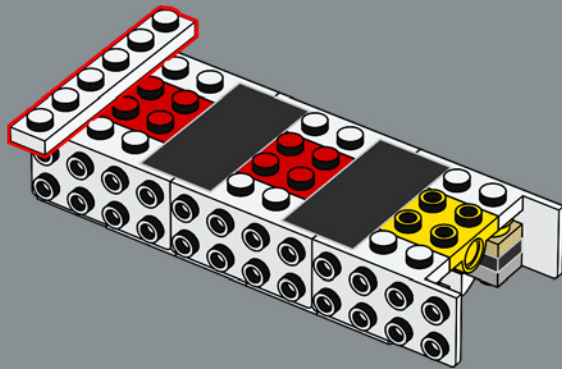

226

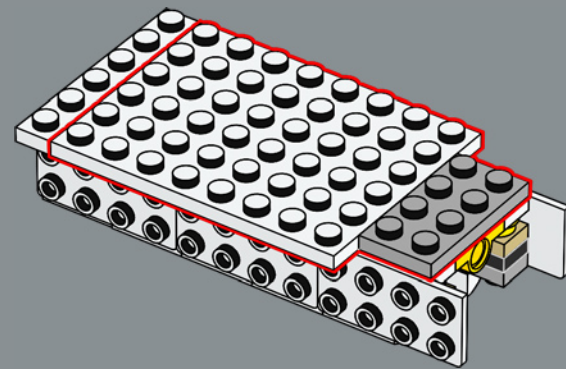

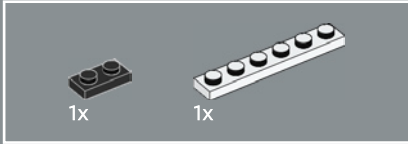
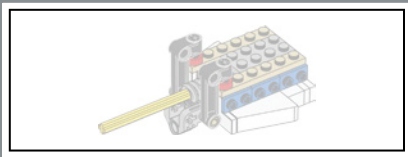

227

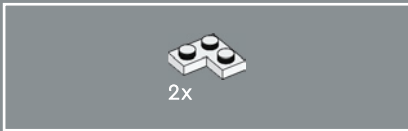
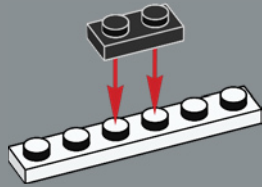

228

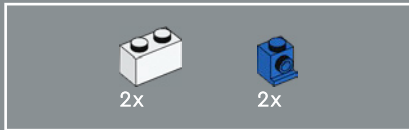
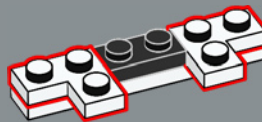

229

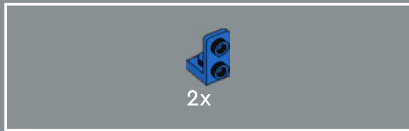
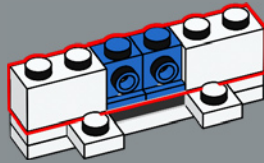

230

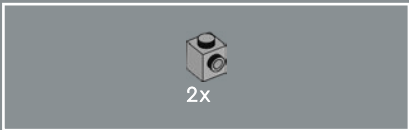
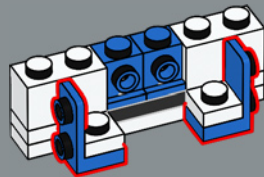

231

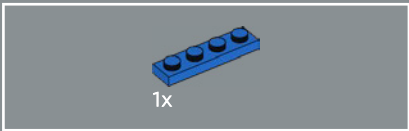
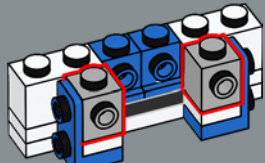

232

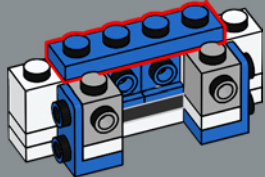

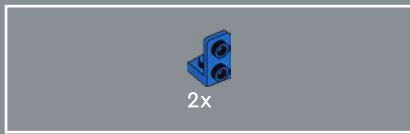

233

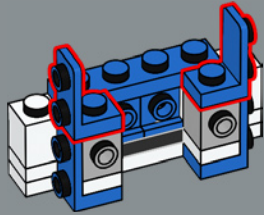

235

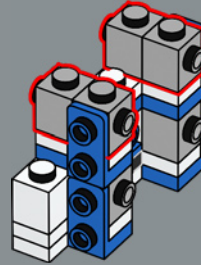

237

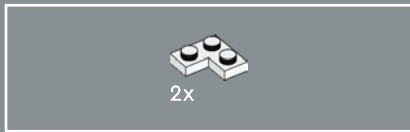
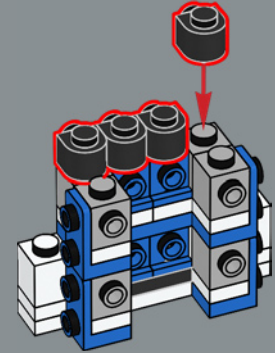

234

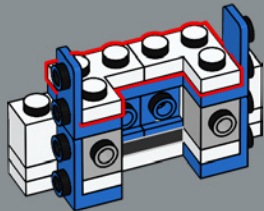

236

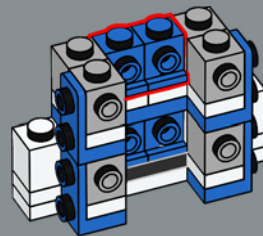

238

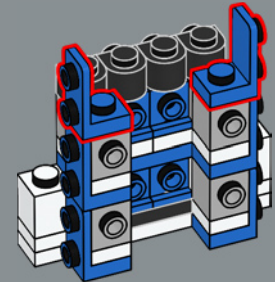



239

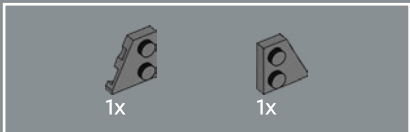
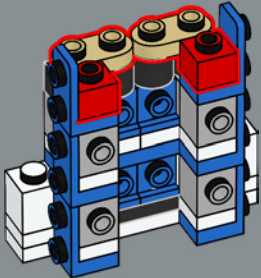

240

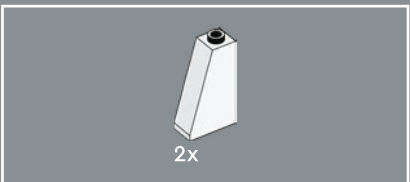
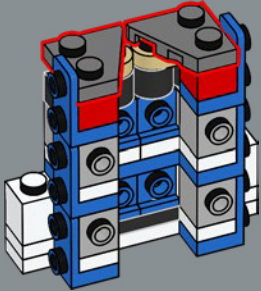

241

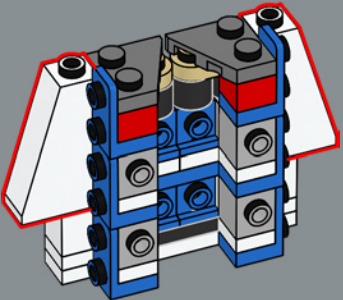

242

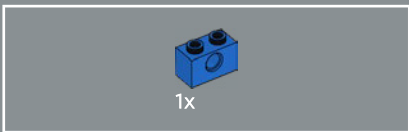
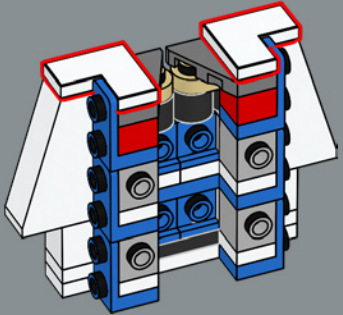

243

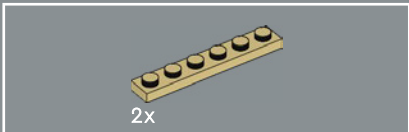
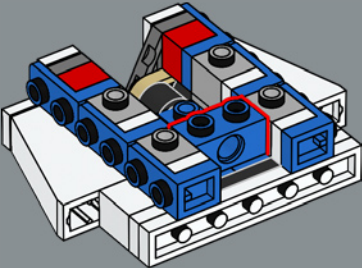

244

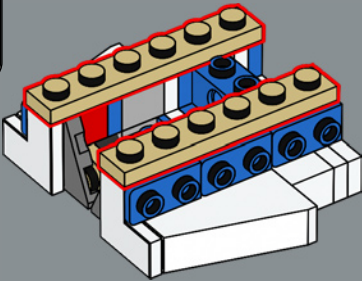

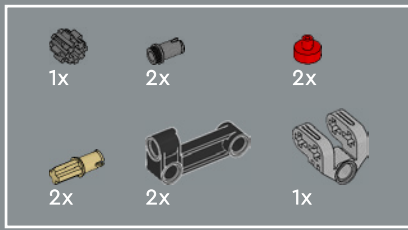

245

1

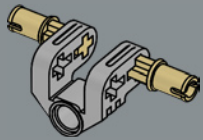

2

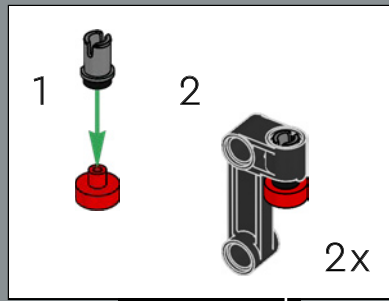
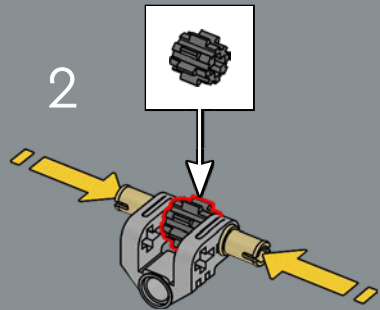

3

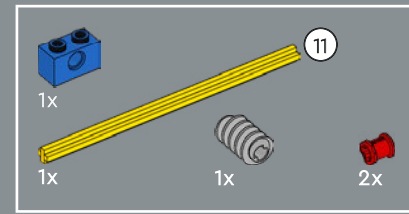
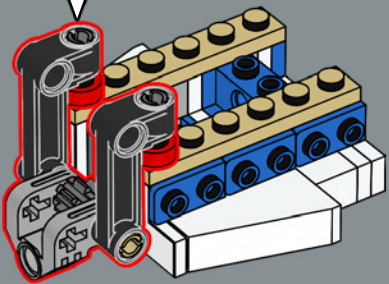
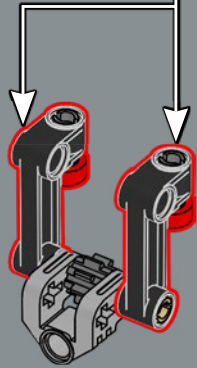

246

1

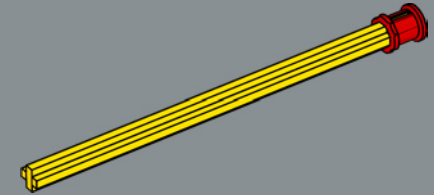

2

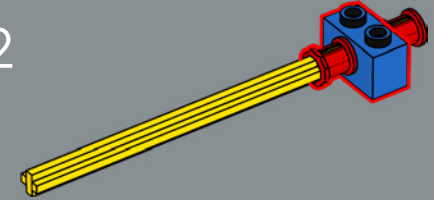

3

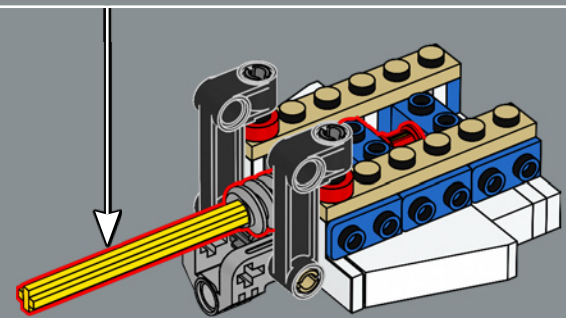
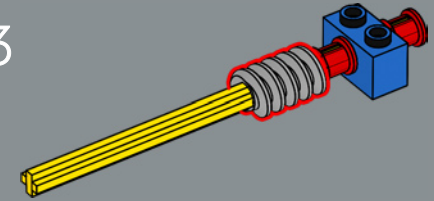

11

1:1

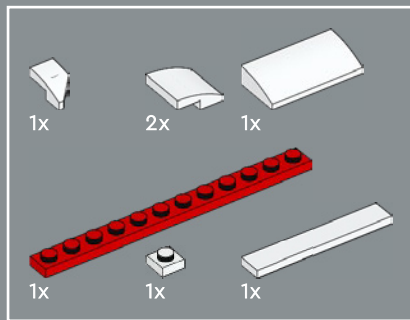

250

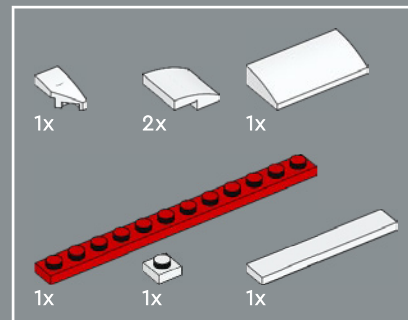
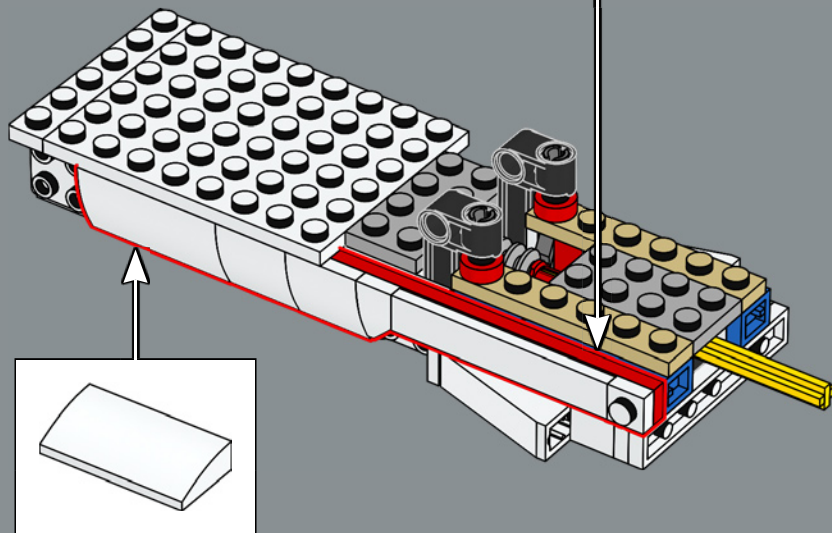
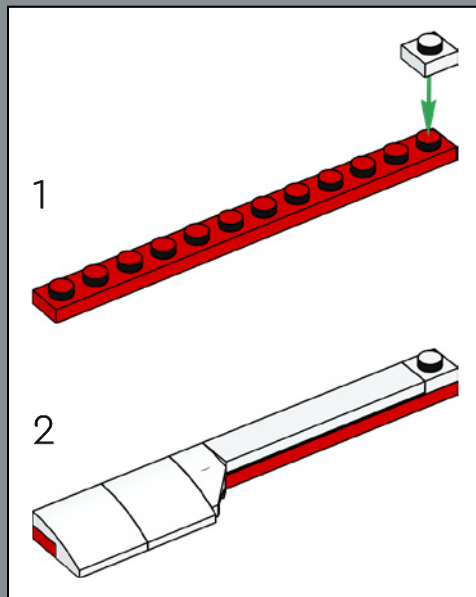

251

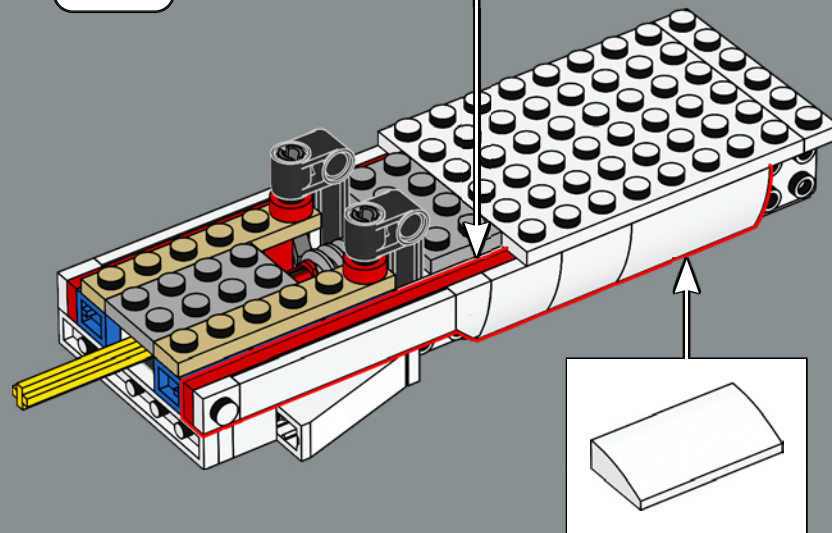
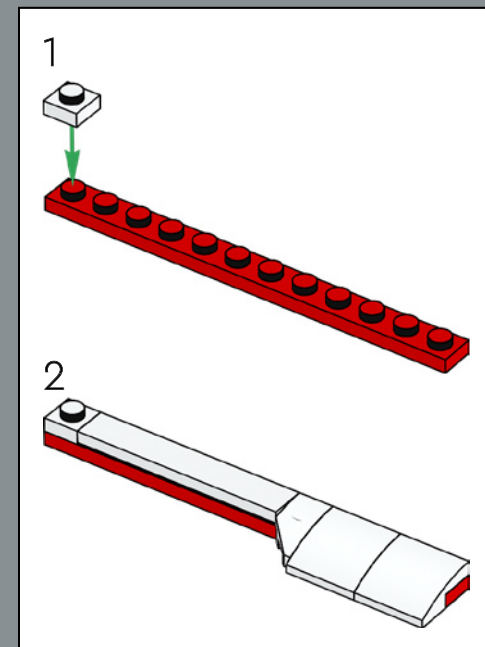



252

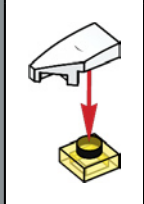
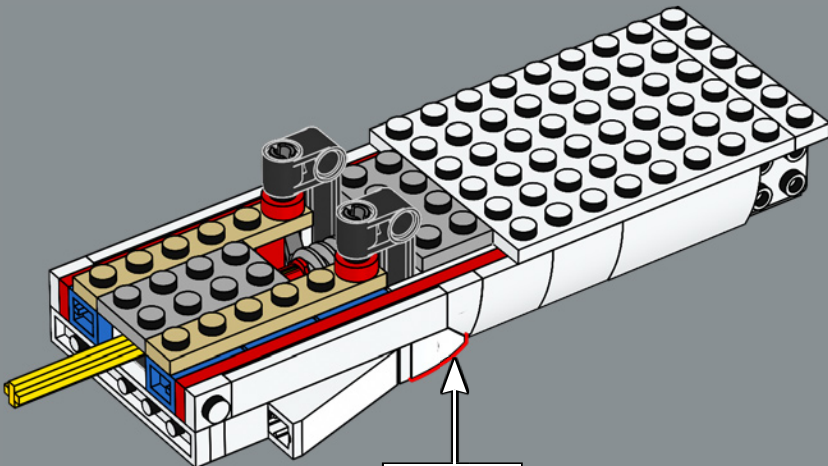

253

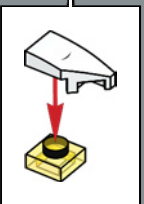
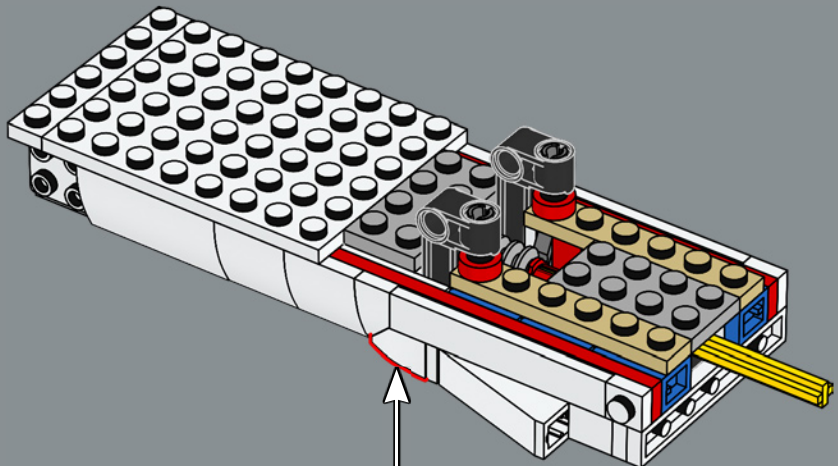

254

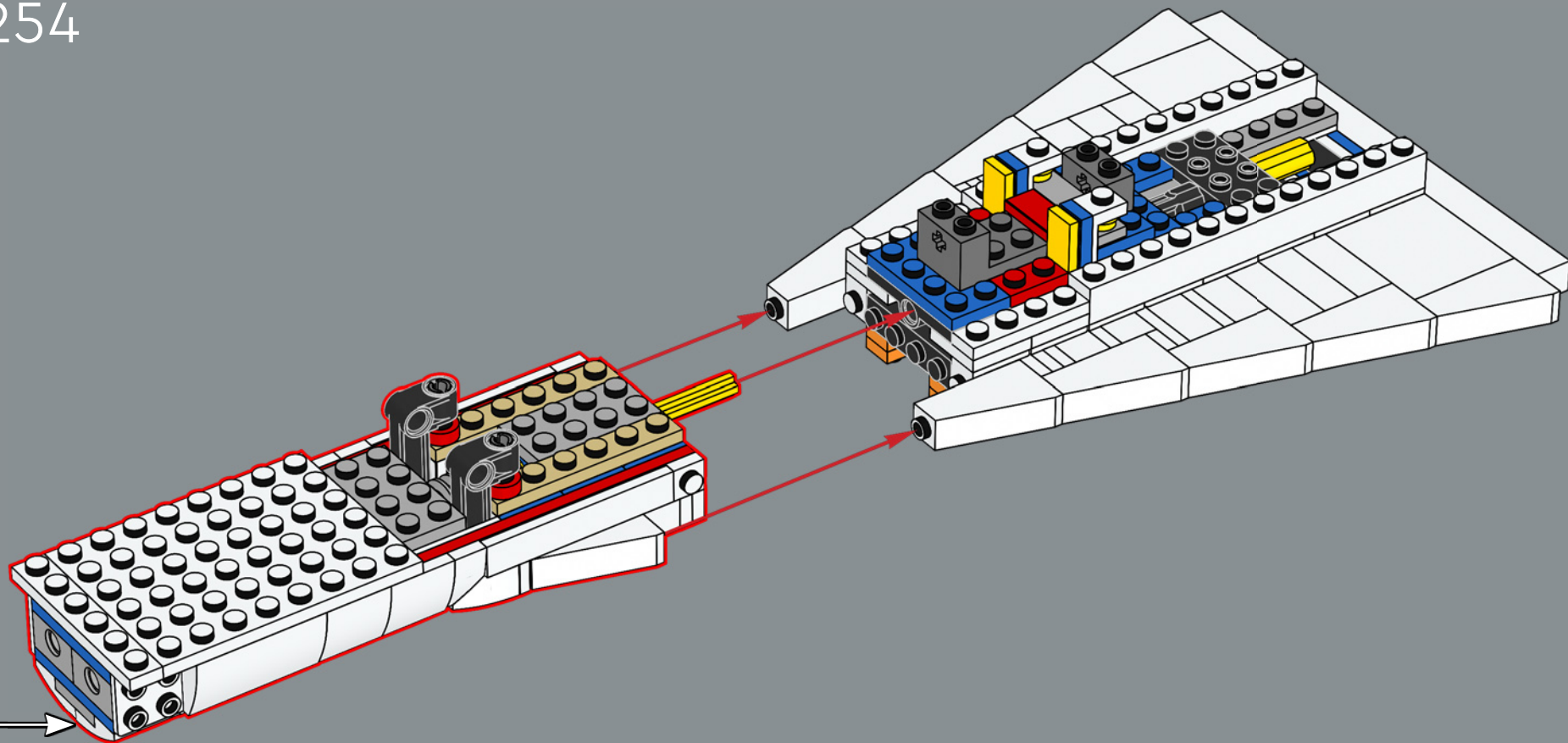

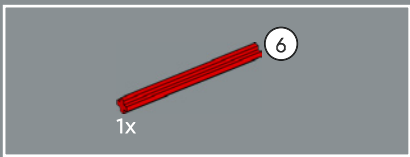

255

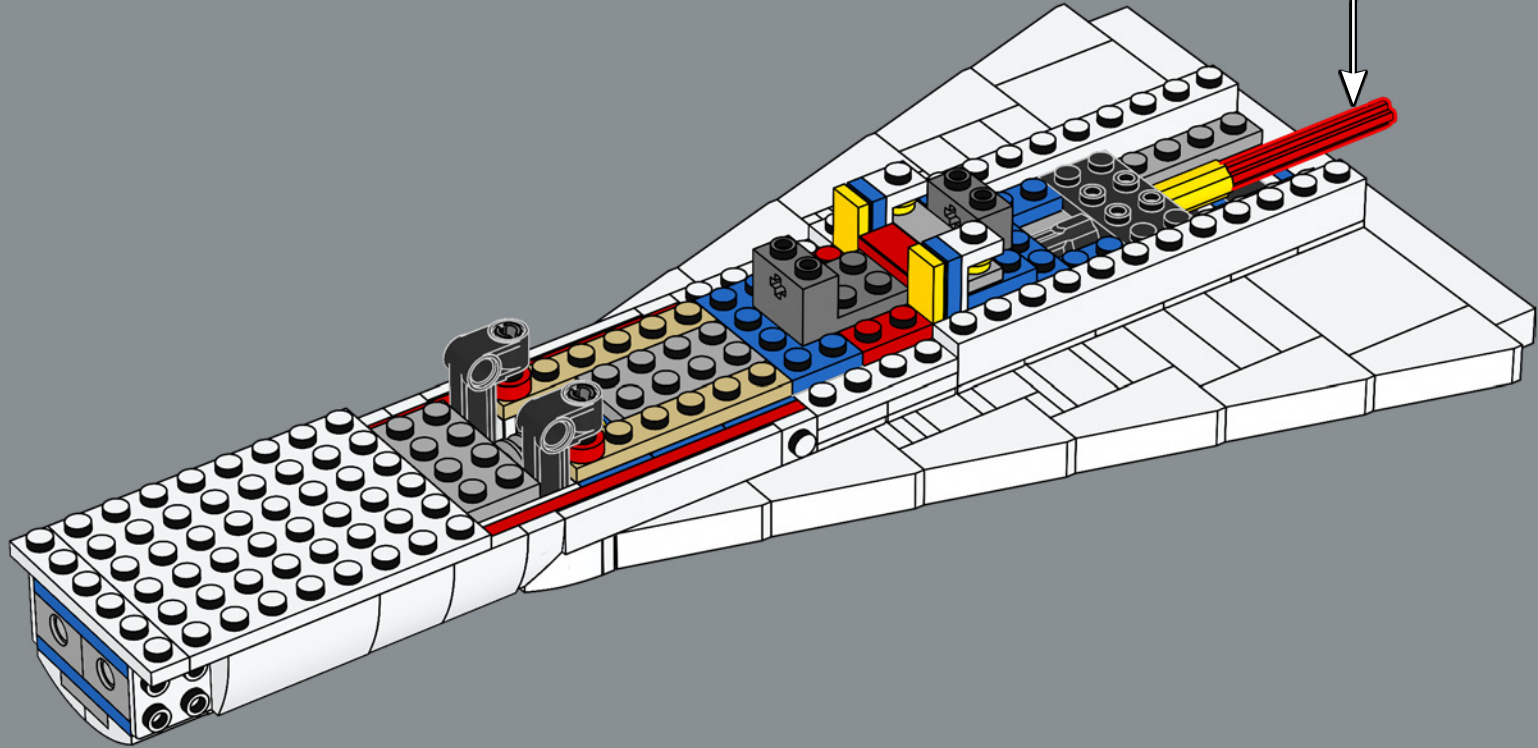
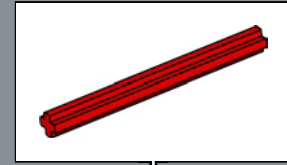

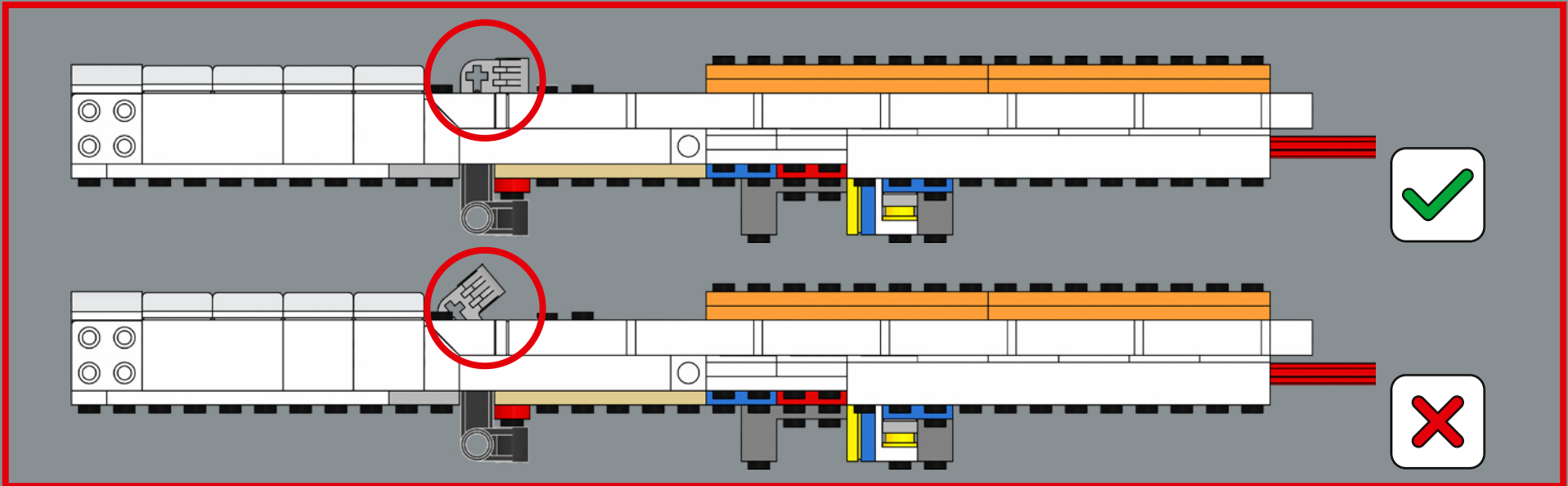
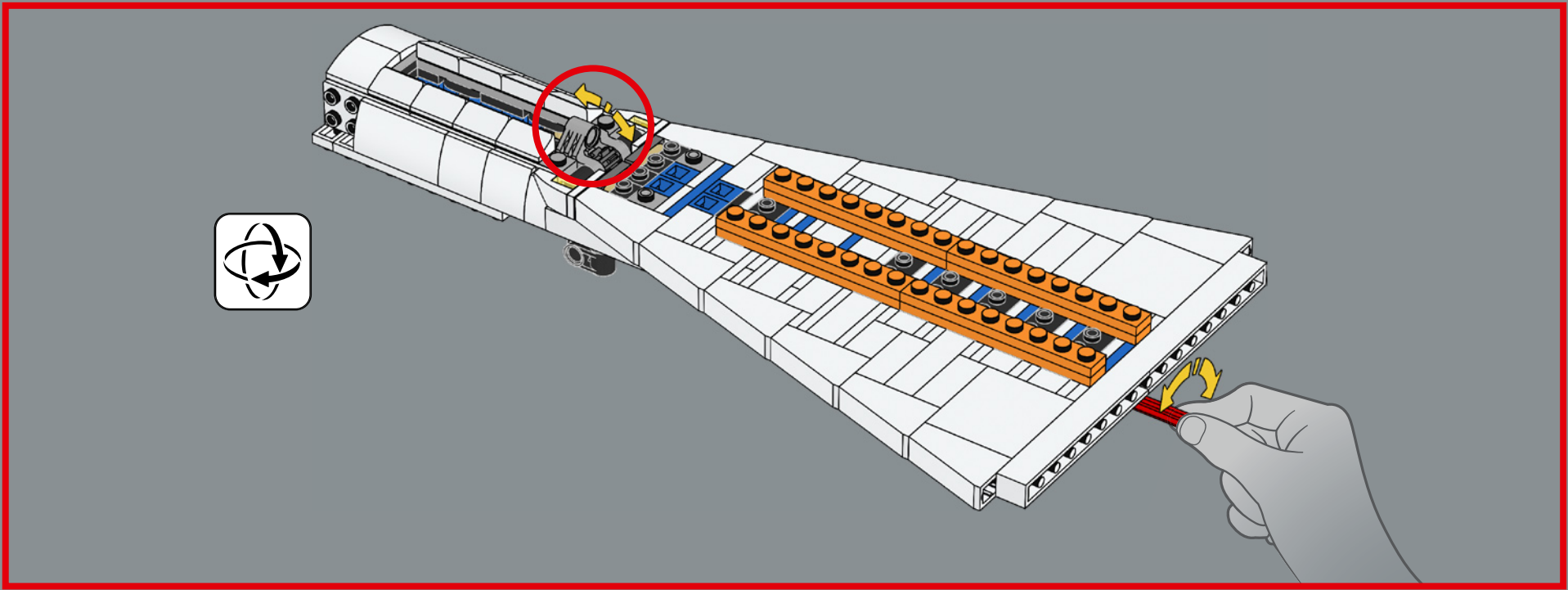

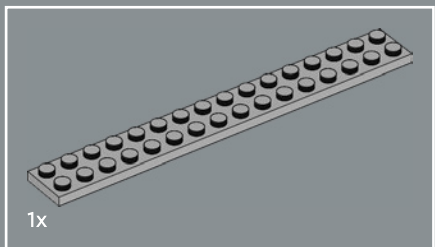

1x

256

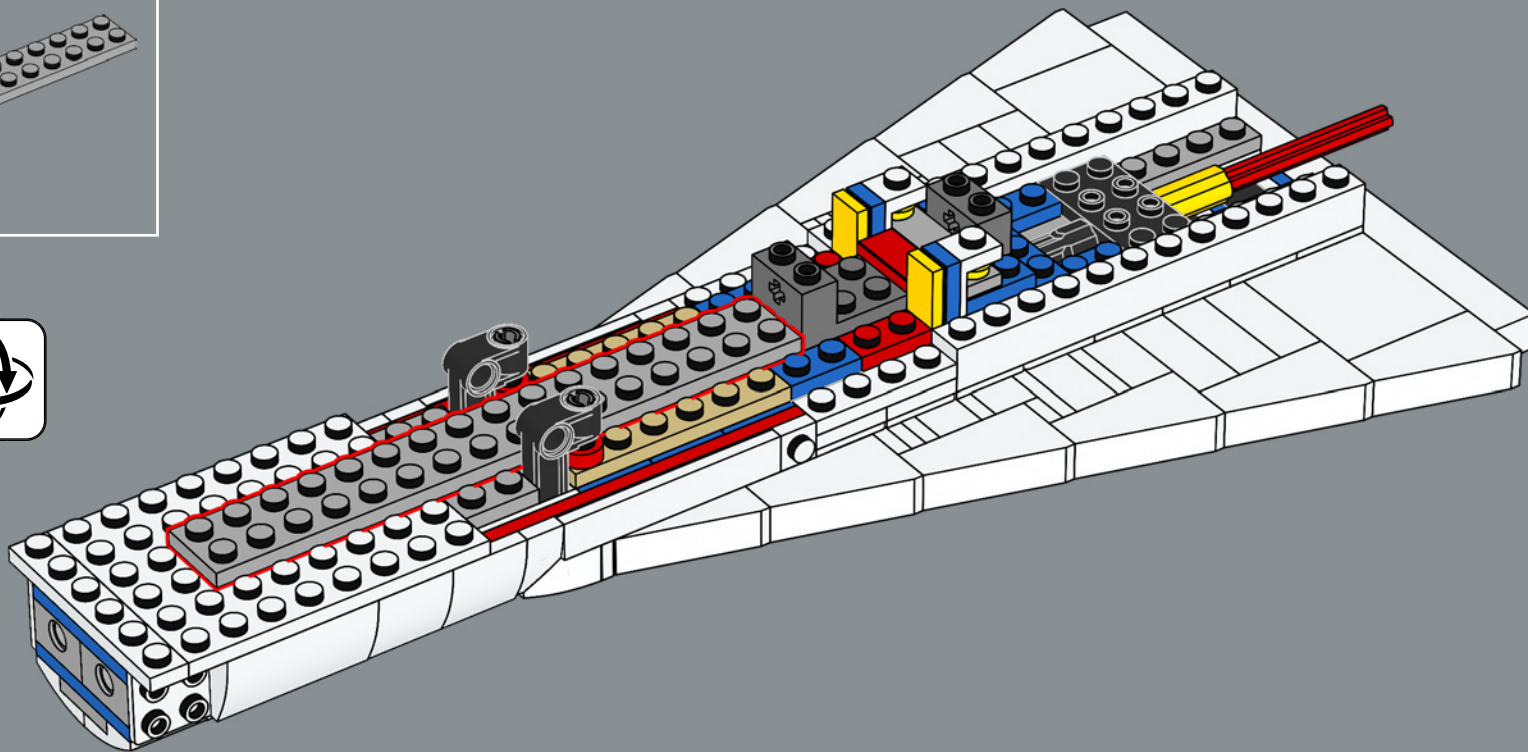

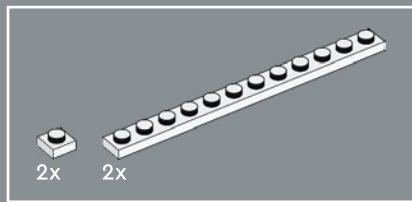

257

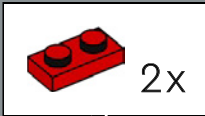
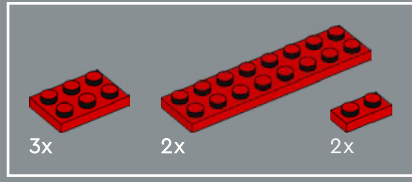
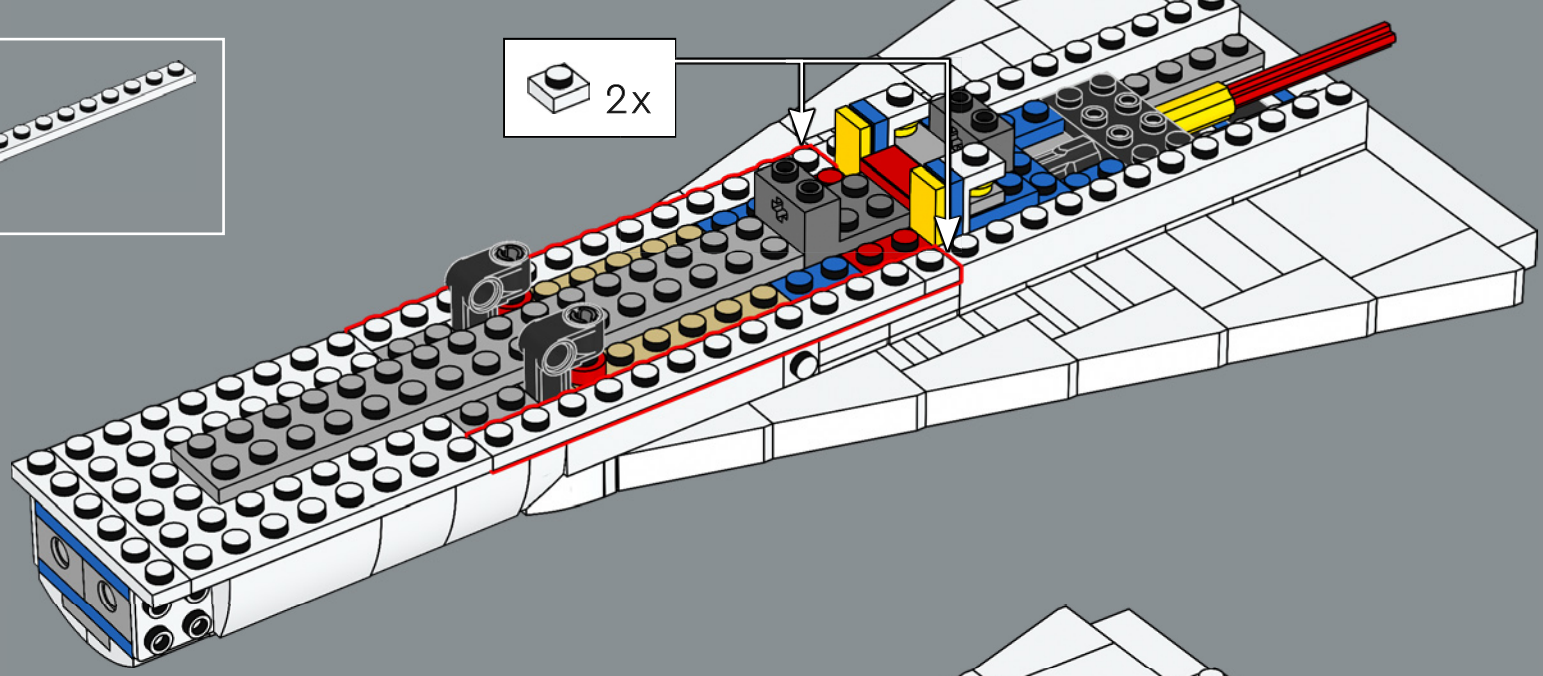

258

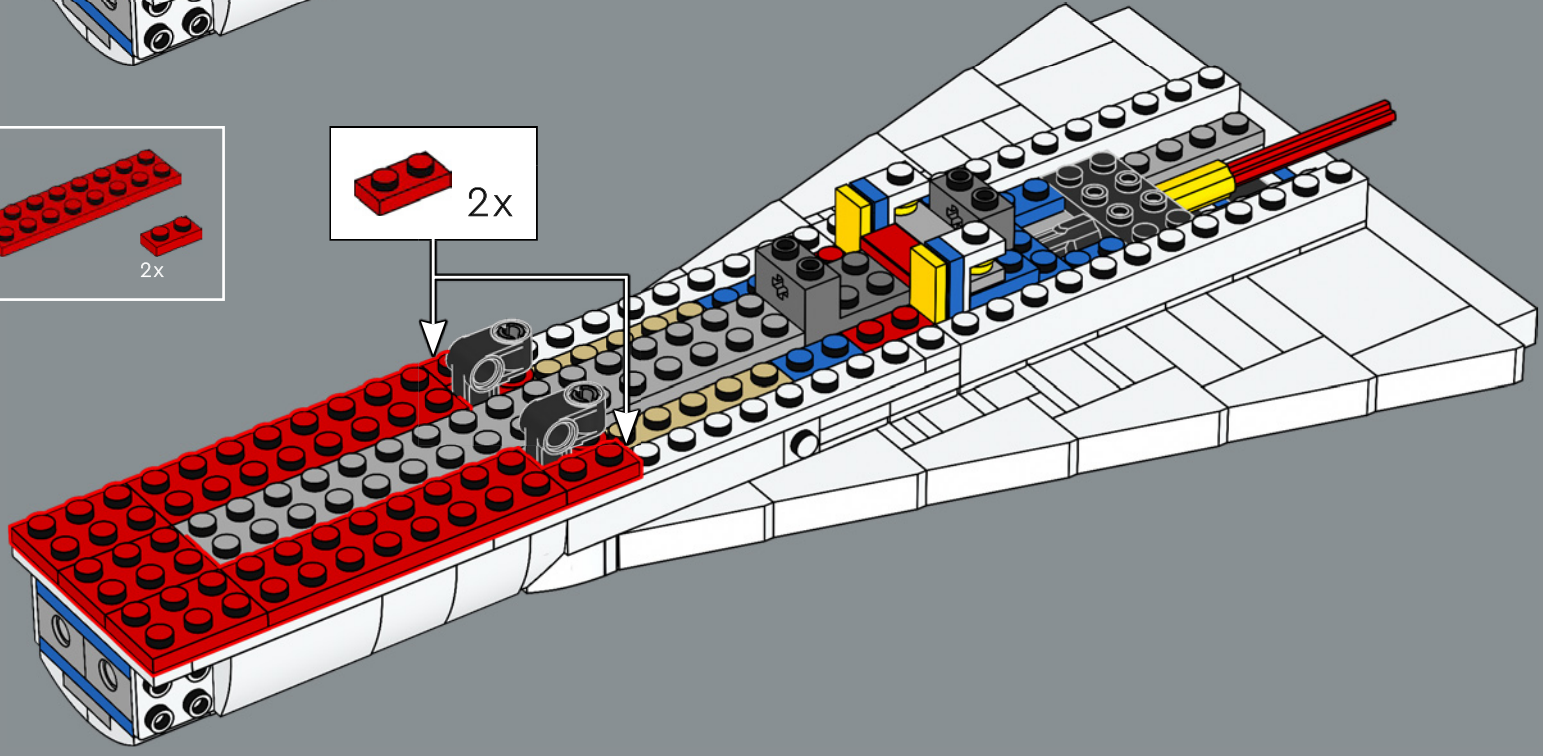

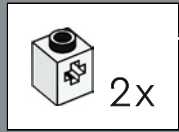
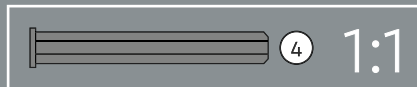
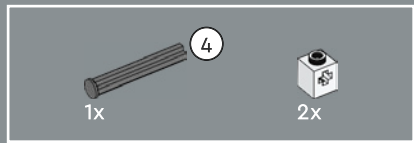

259

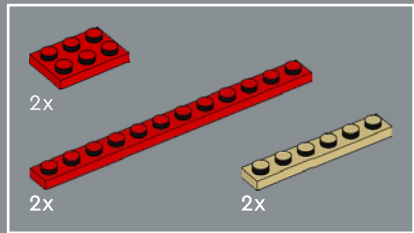
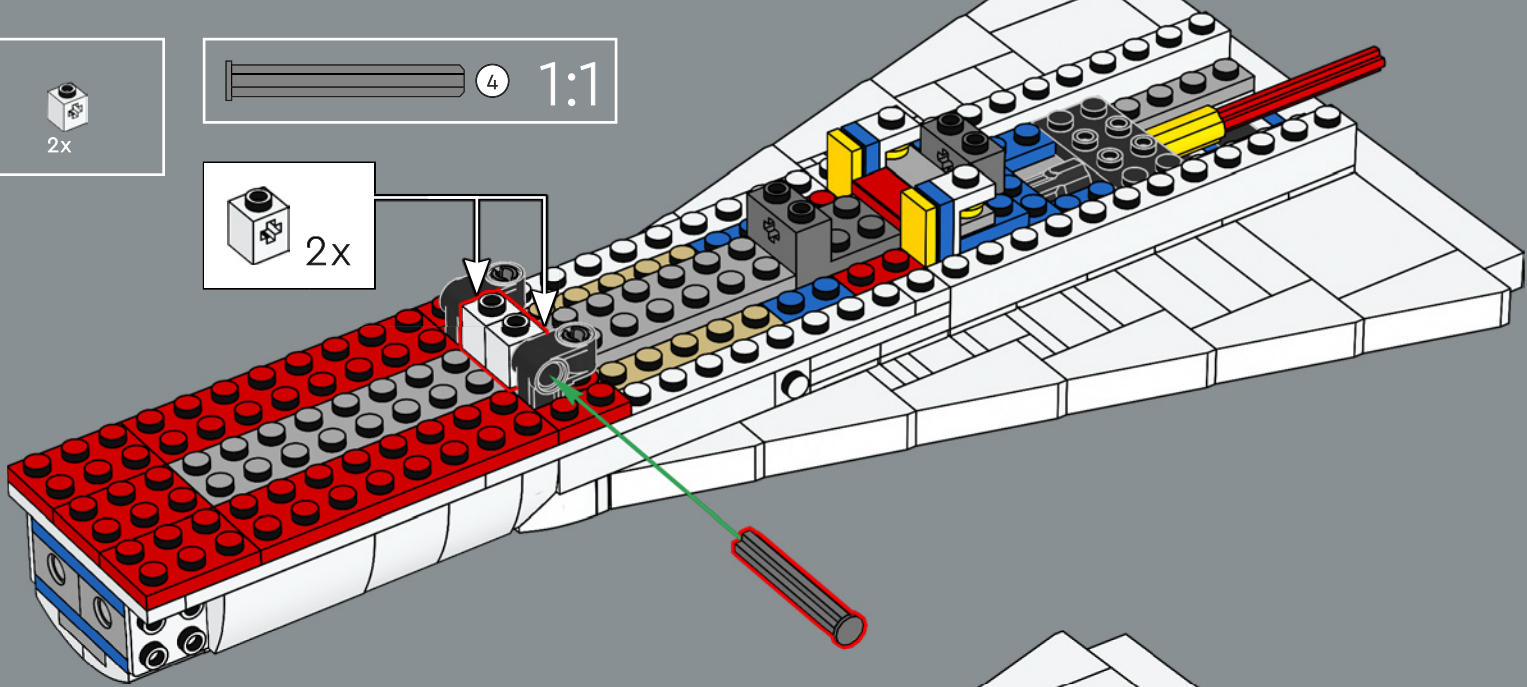

260

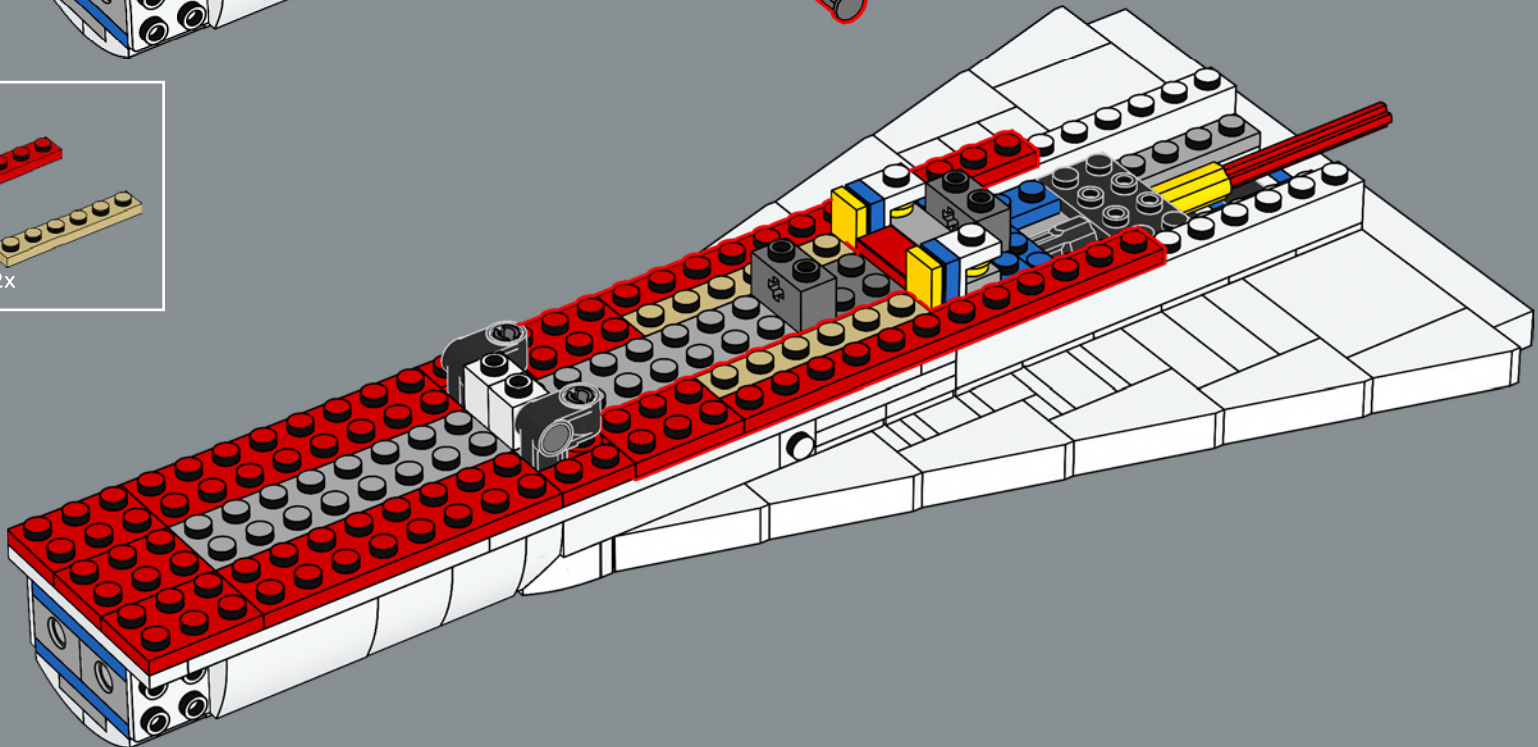

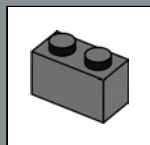
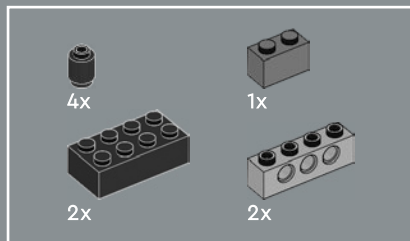

261

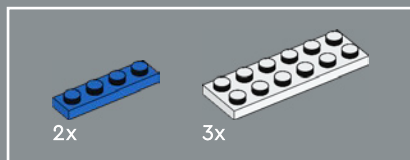
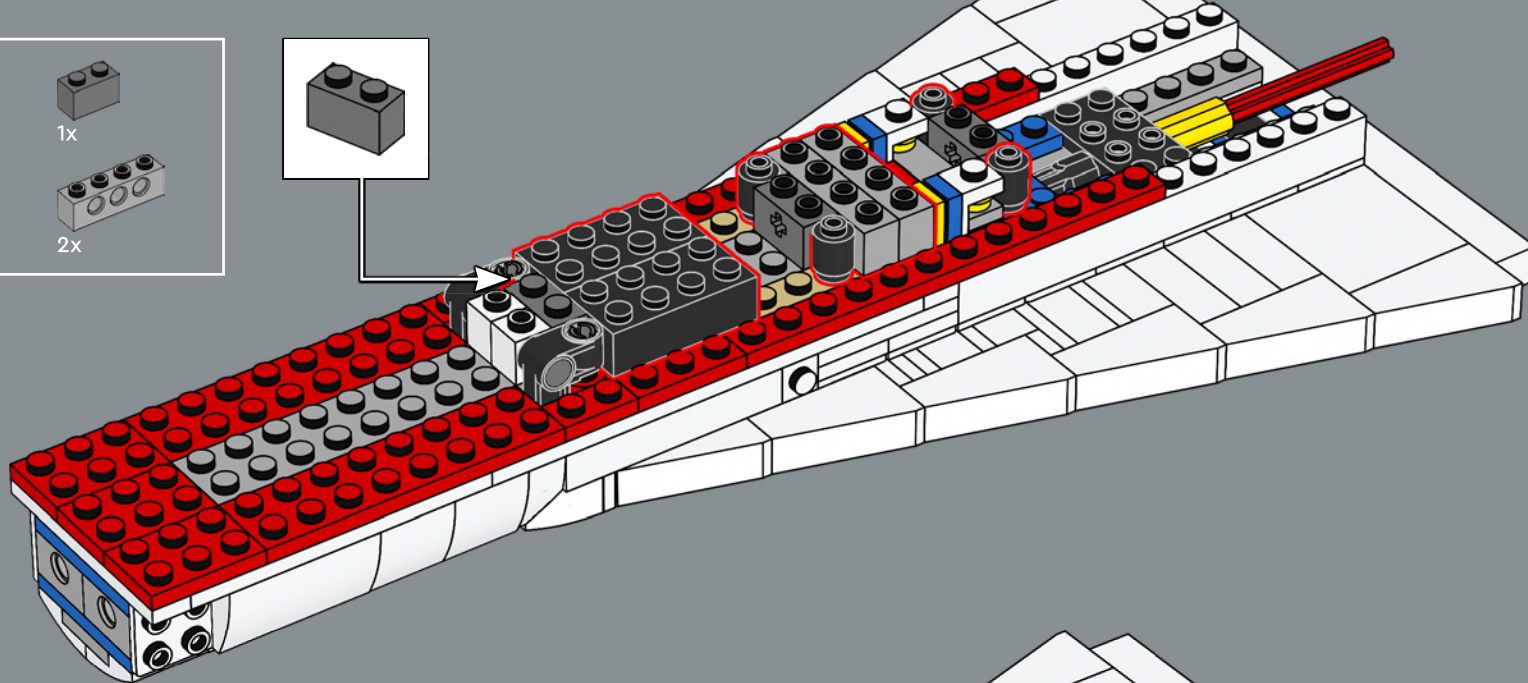

262

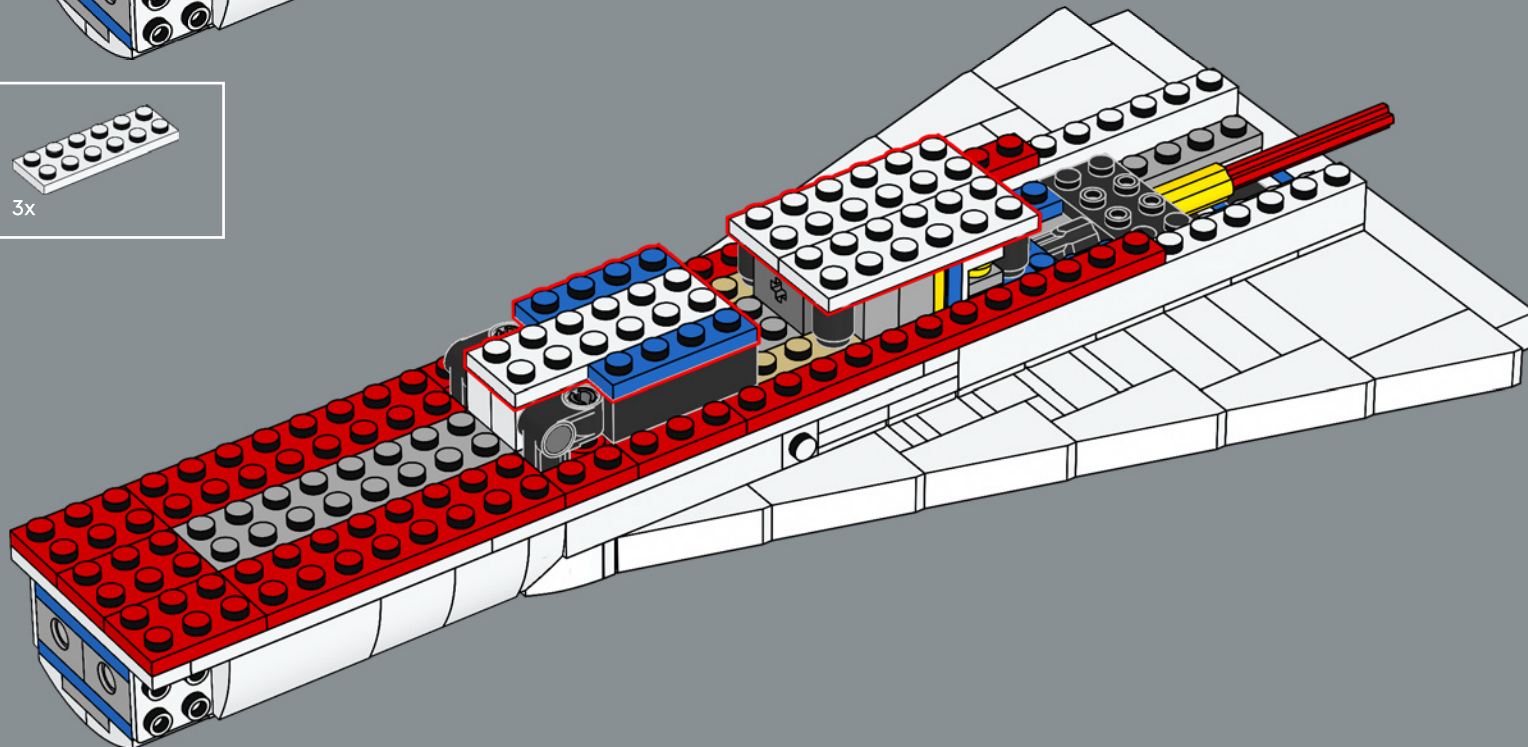

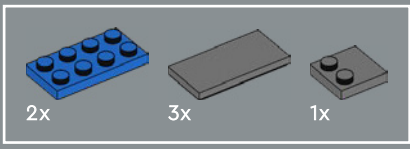

263

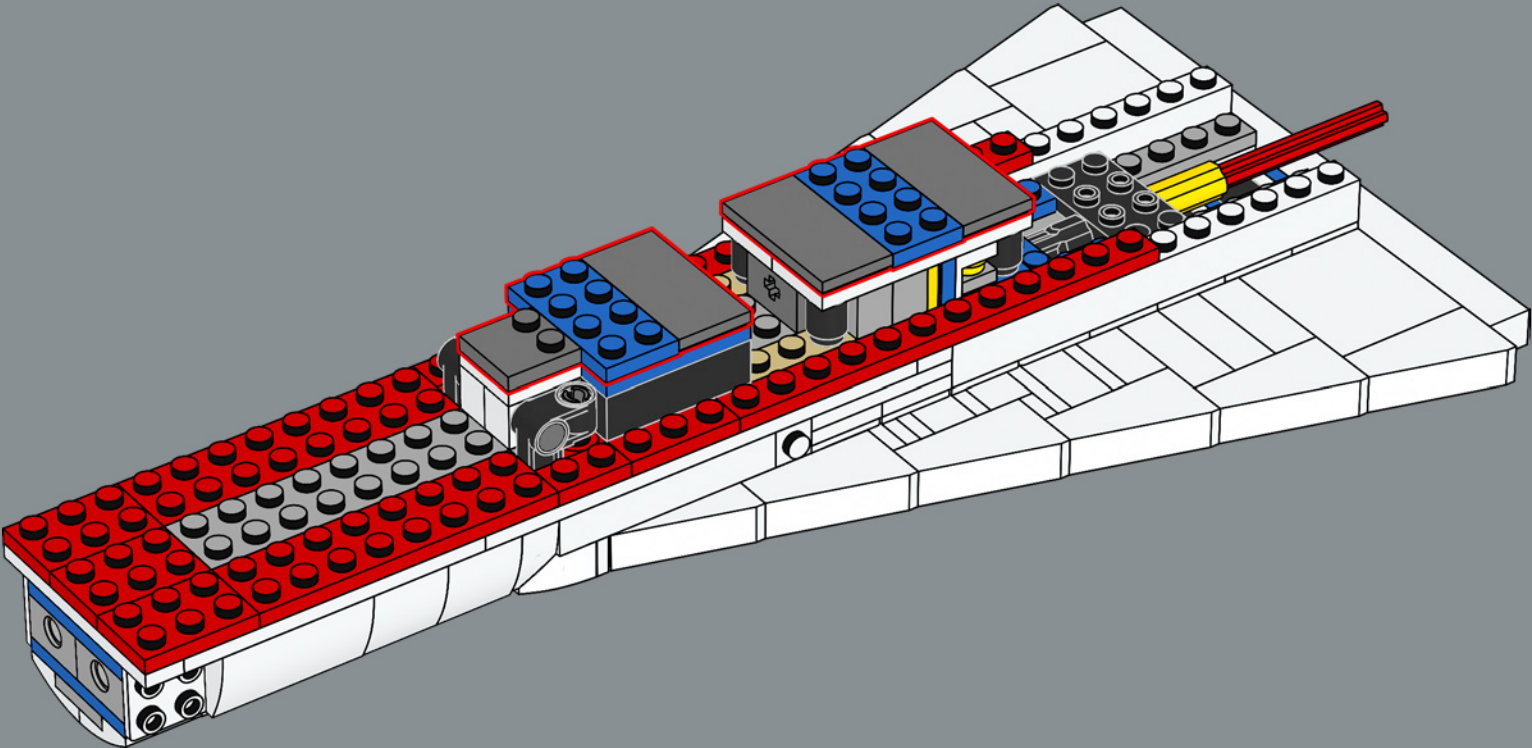



当以巡航速度飞行时，协和式飞机的机身会被加热到使飞机延伸 15-25 厘米 (6-10 英寸) 的程度!

264

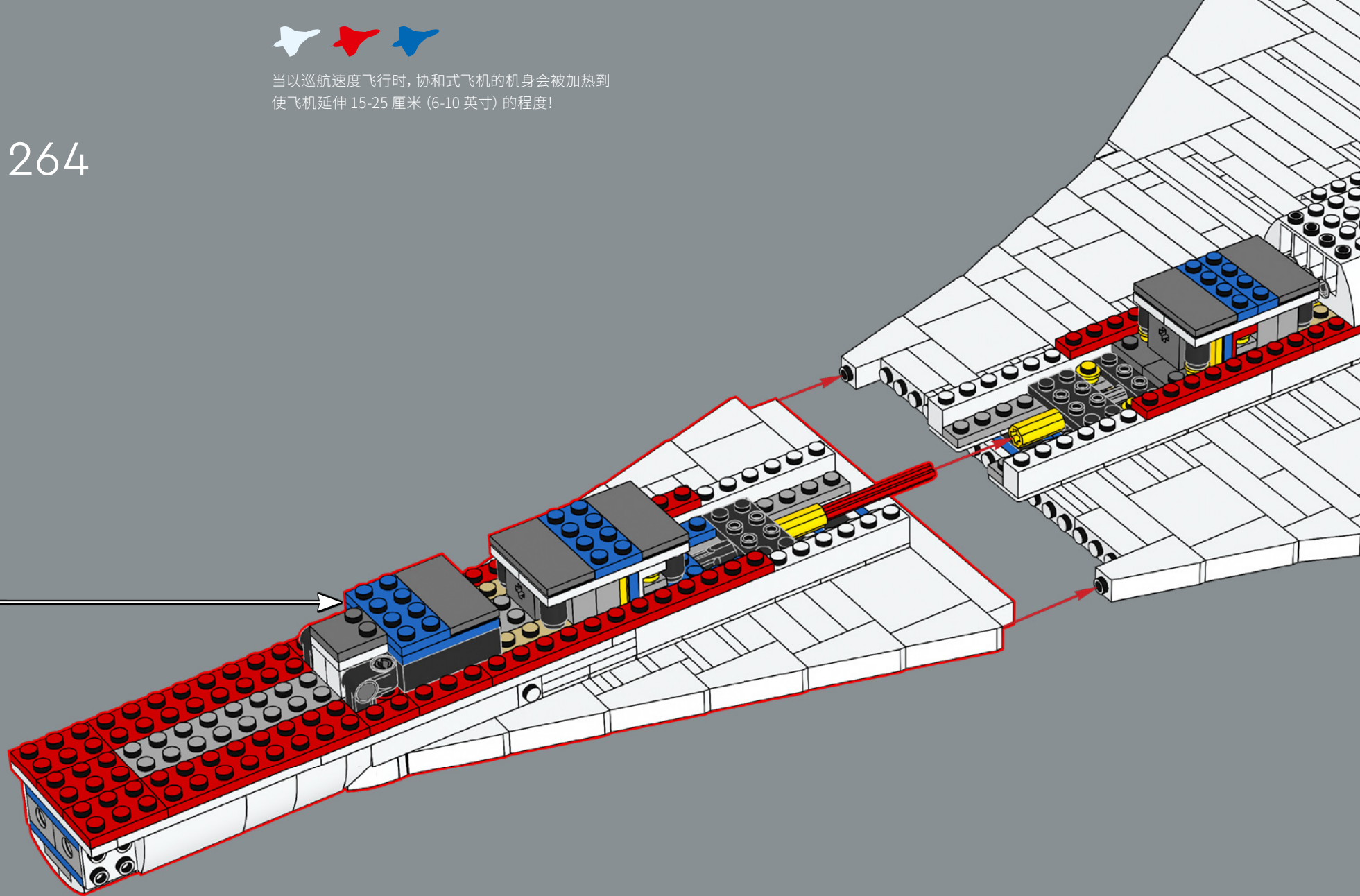

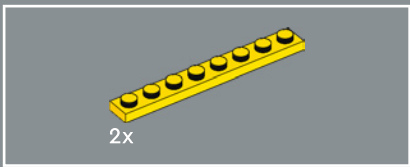

265

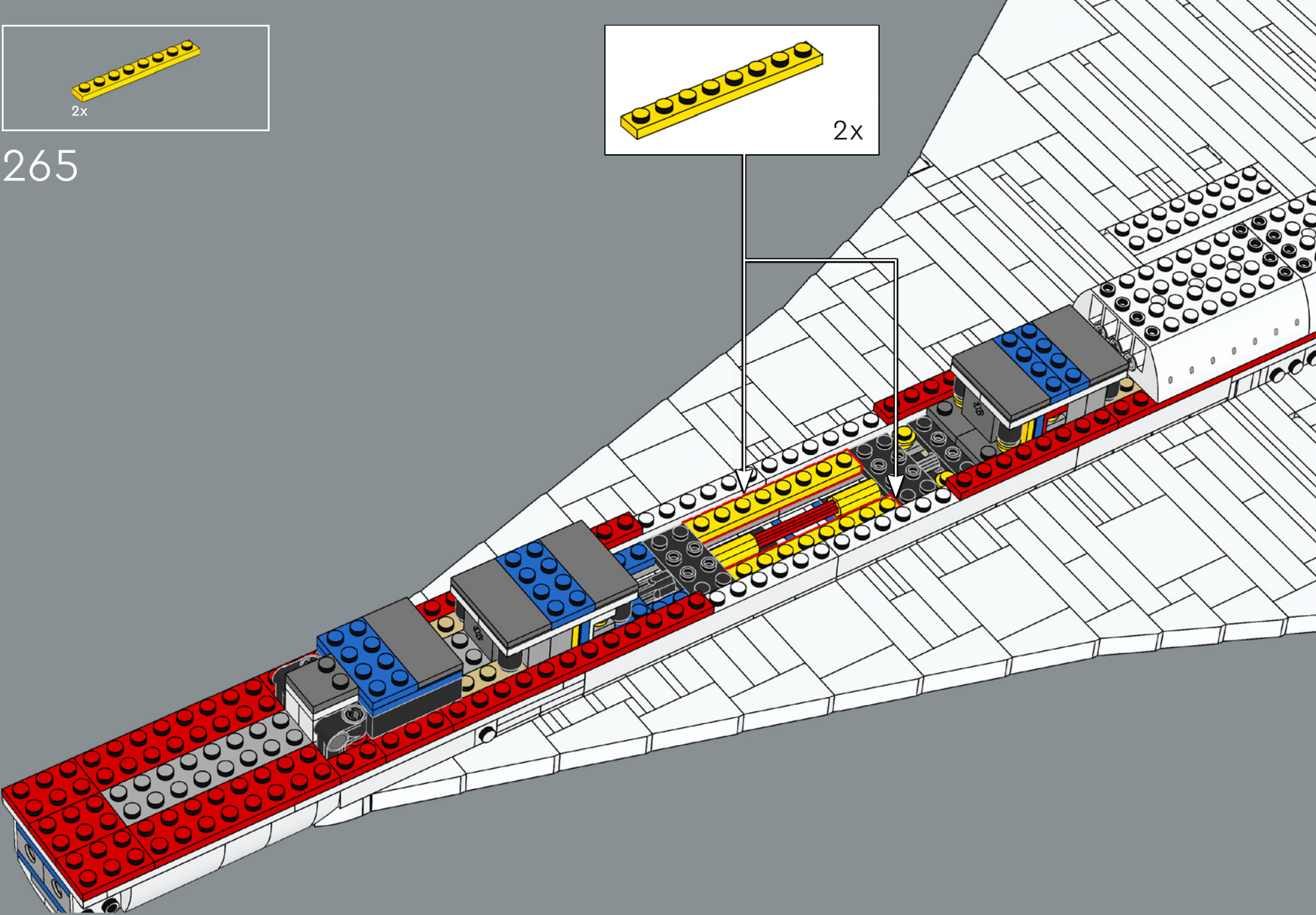
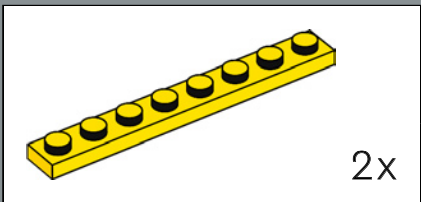

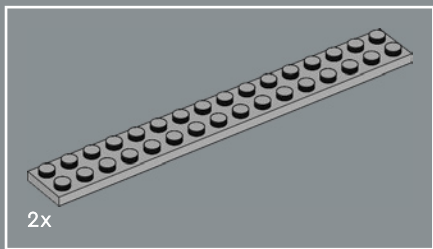

266

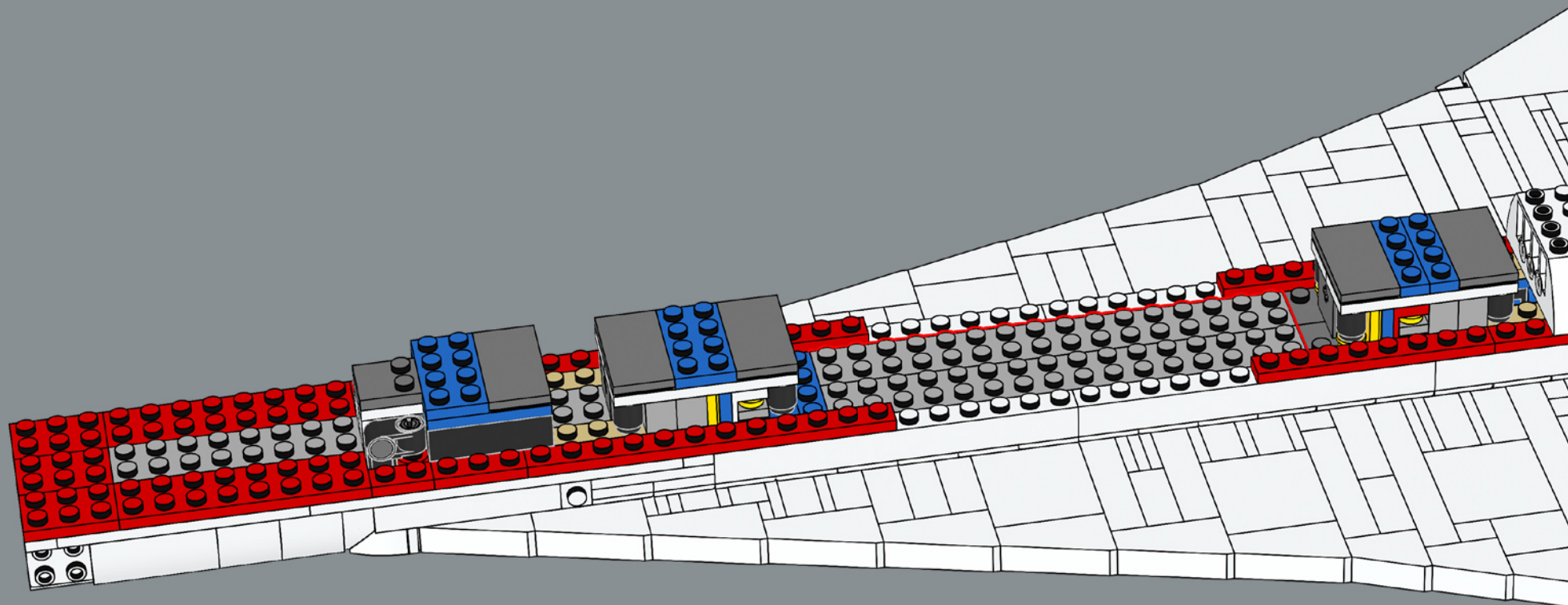

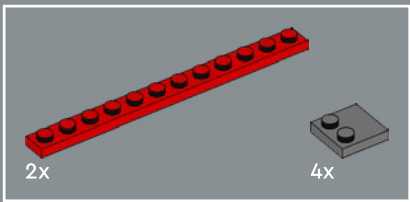

267

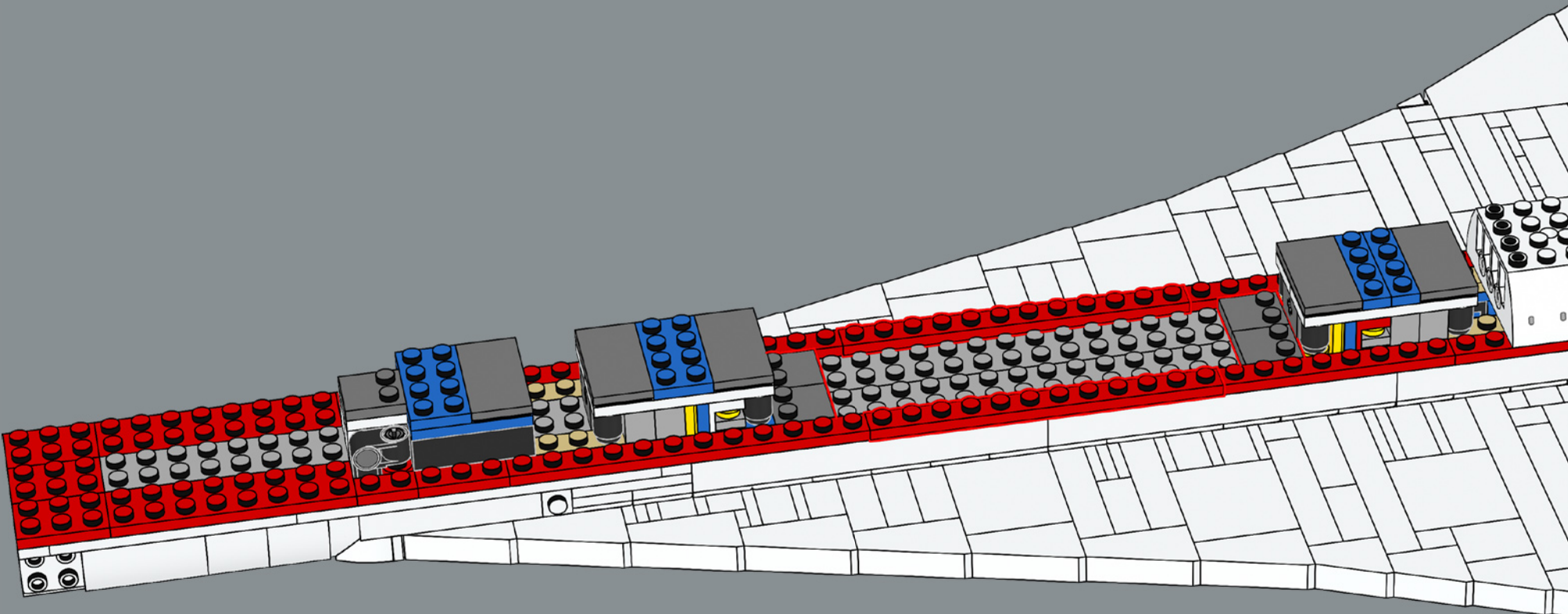

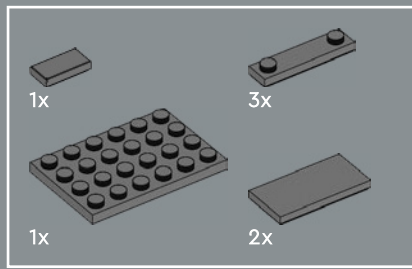

268

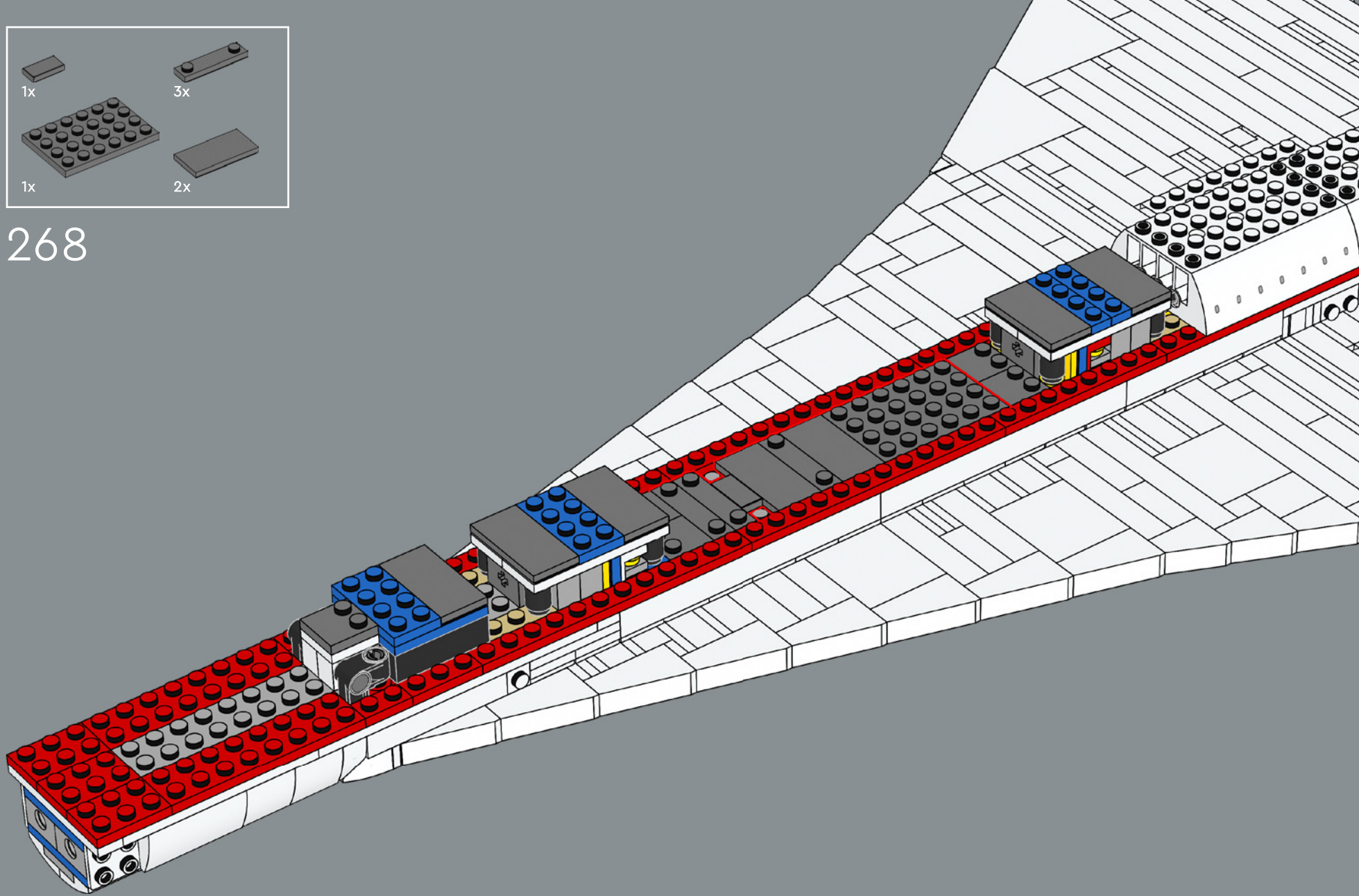

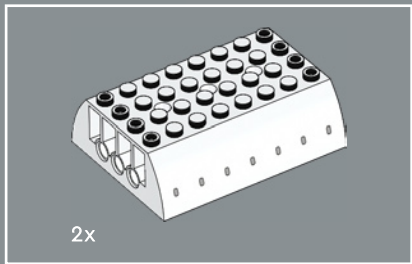

269

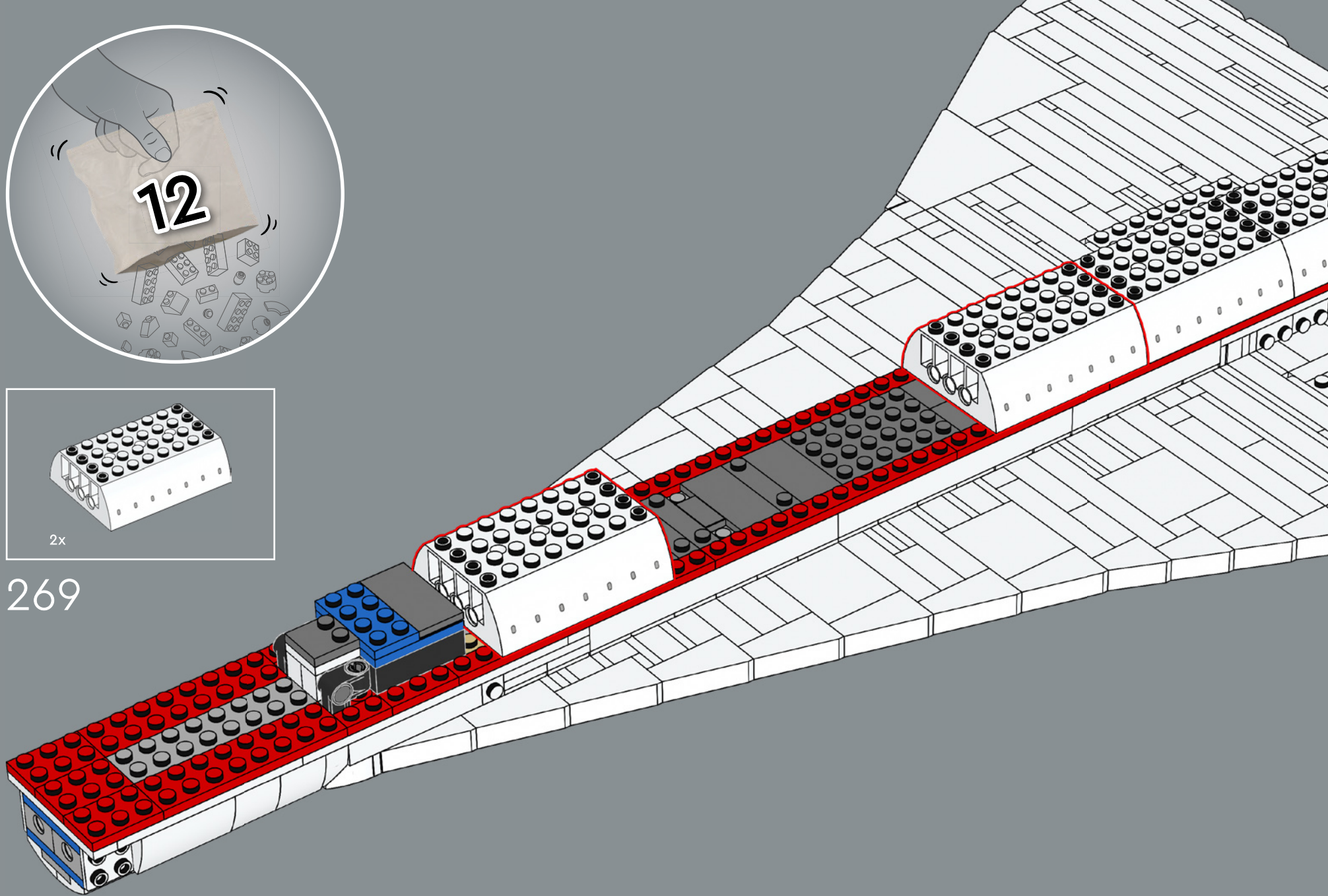

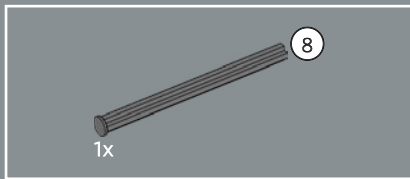

270

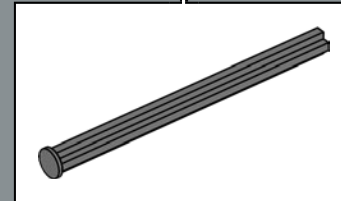
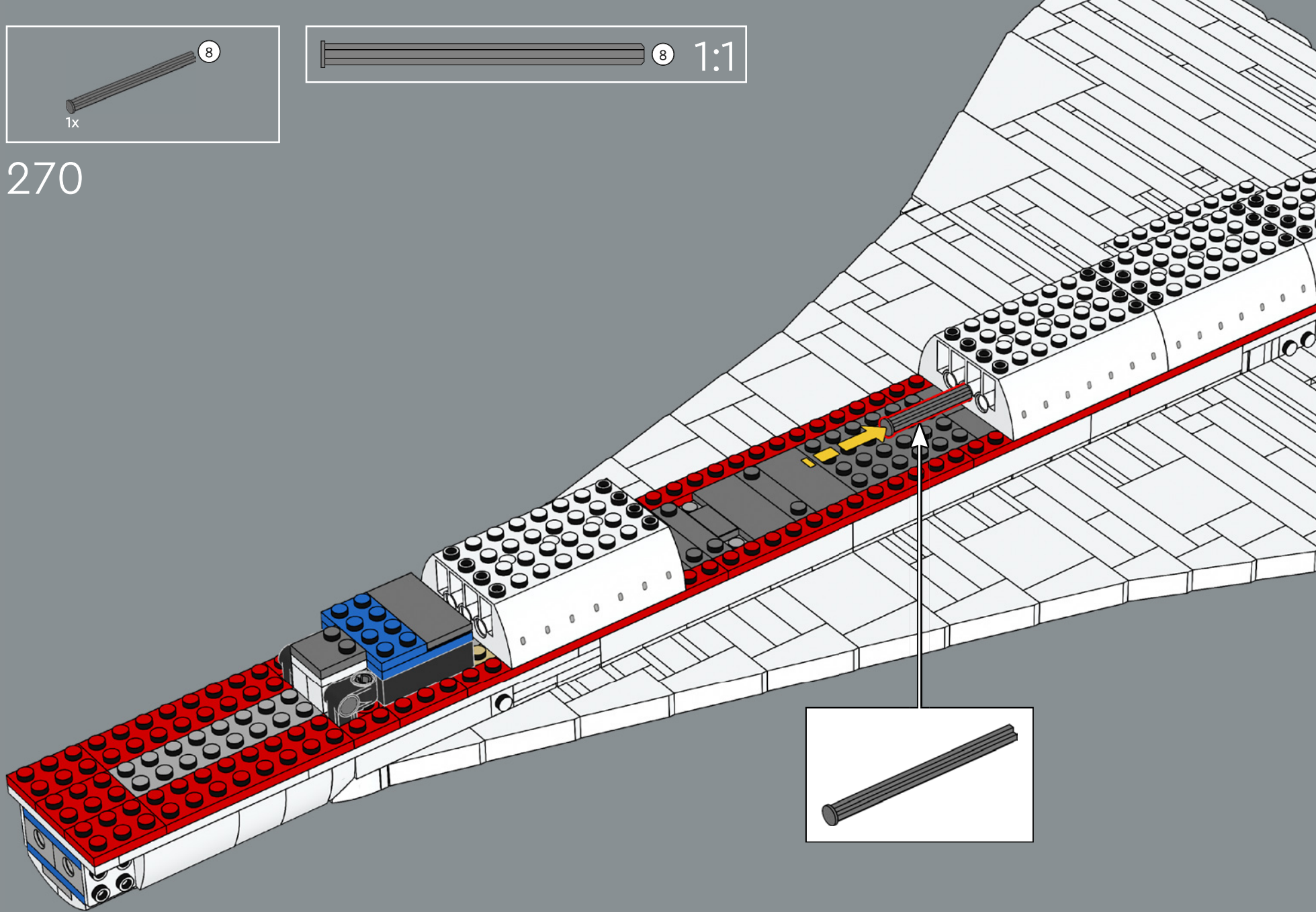

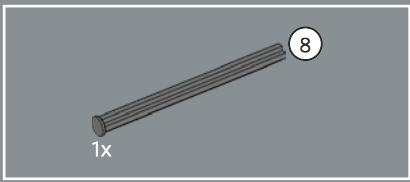

271

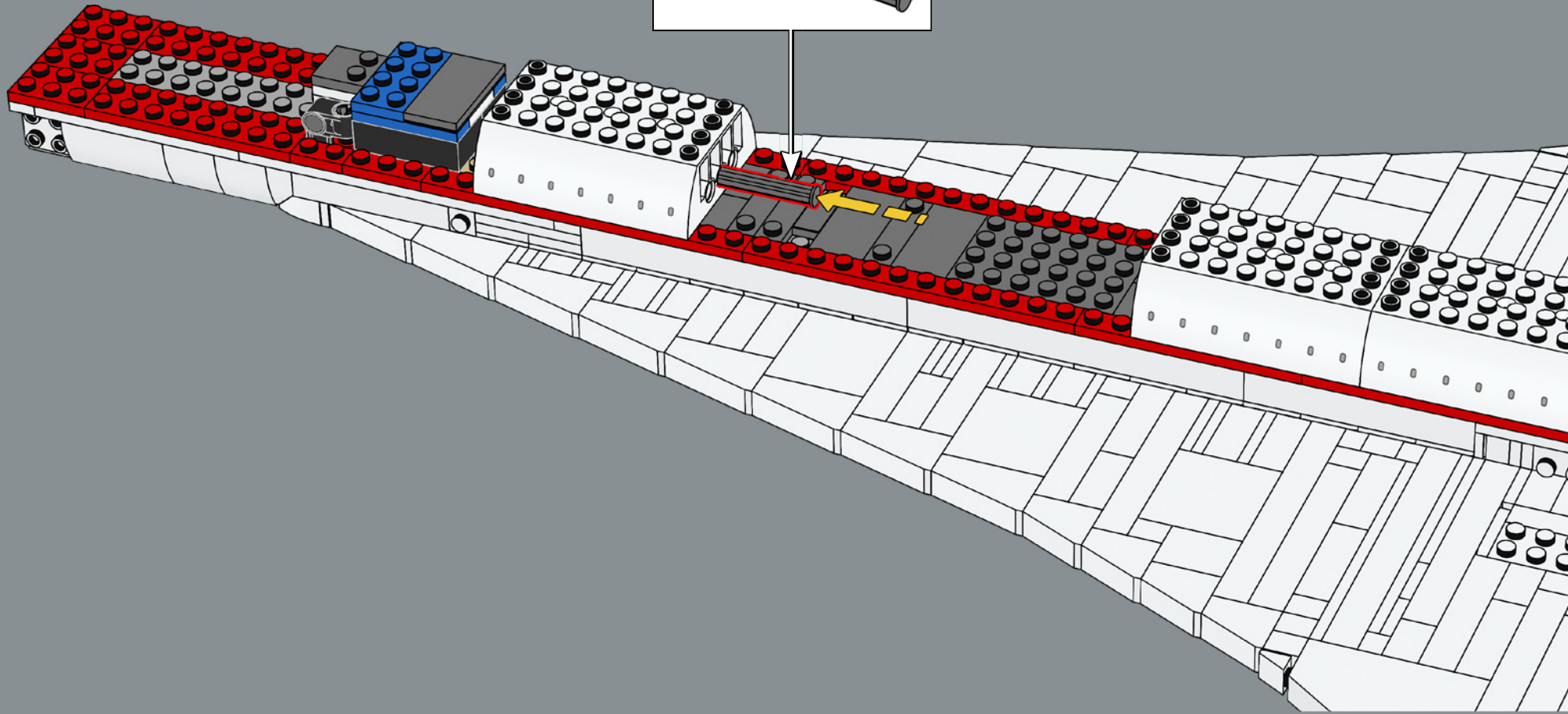
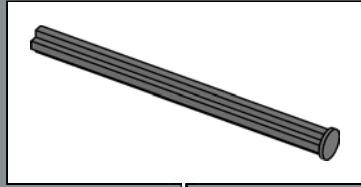

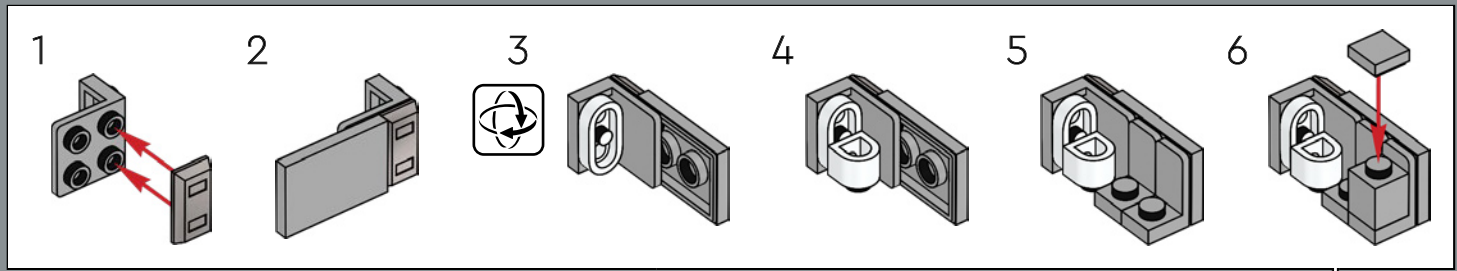
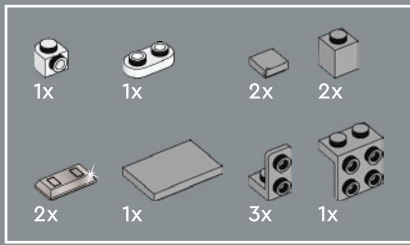

272

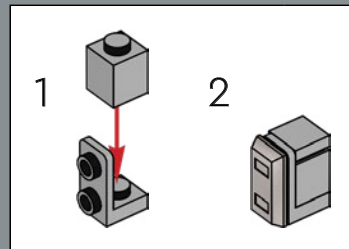
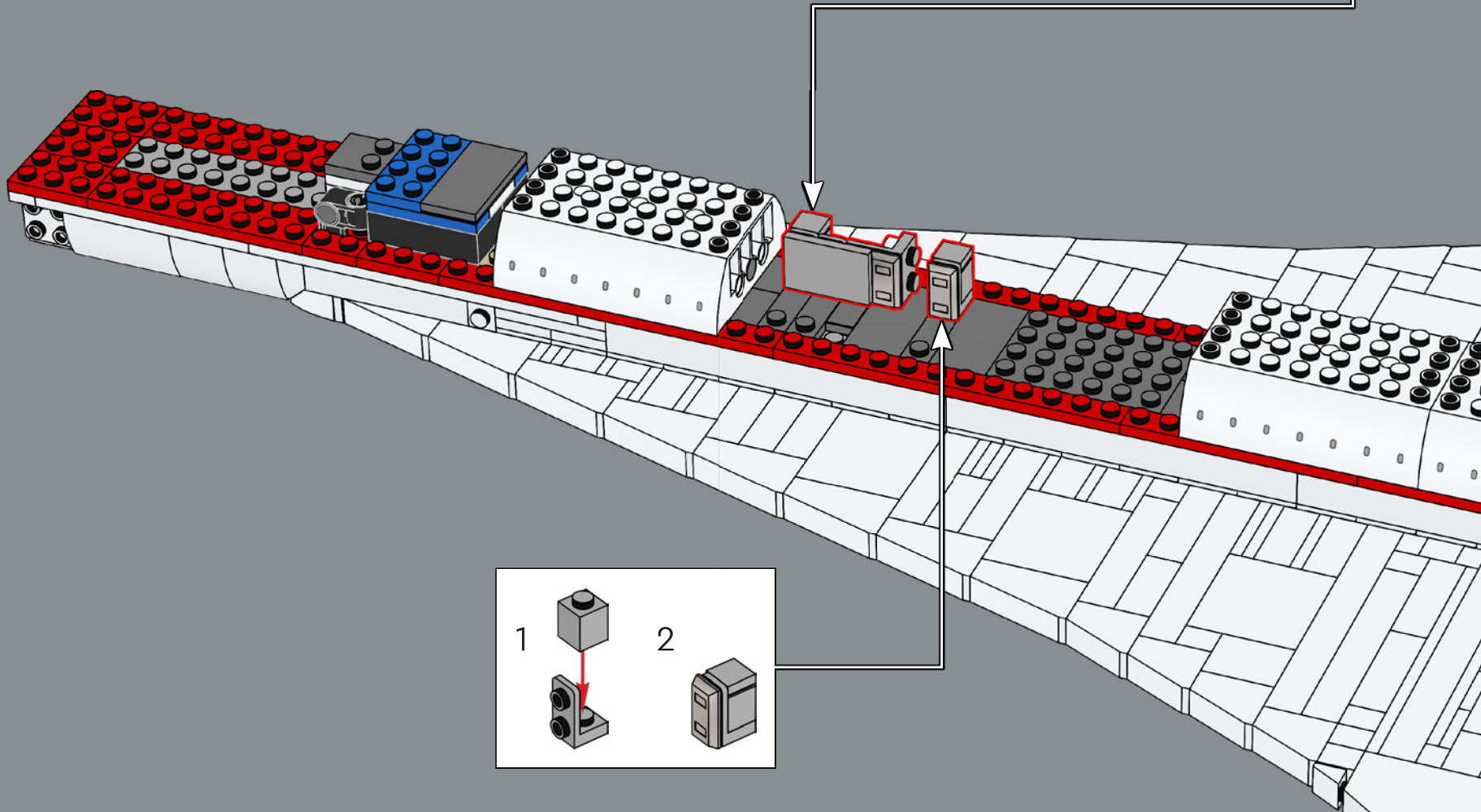

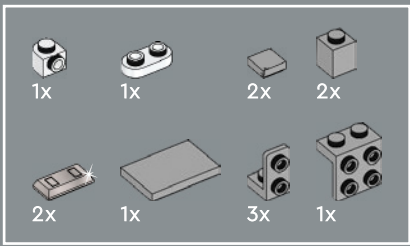

273

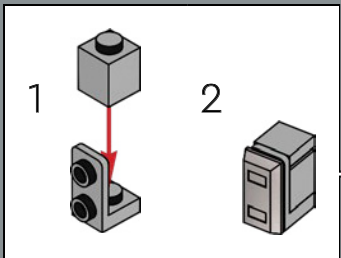
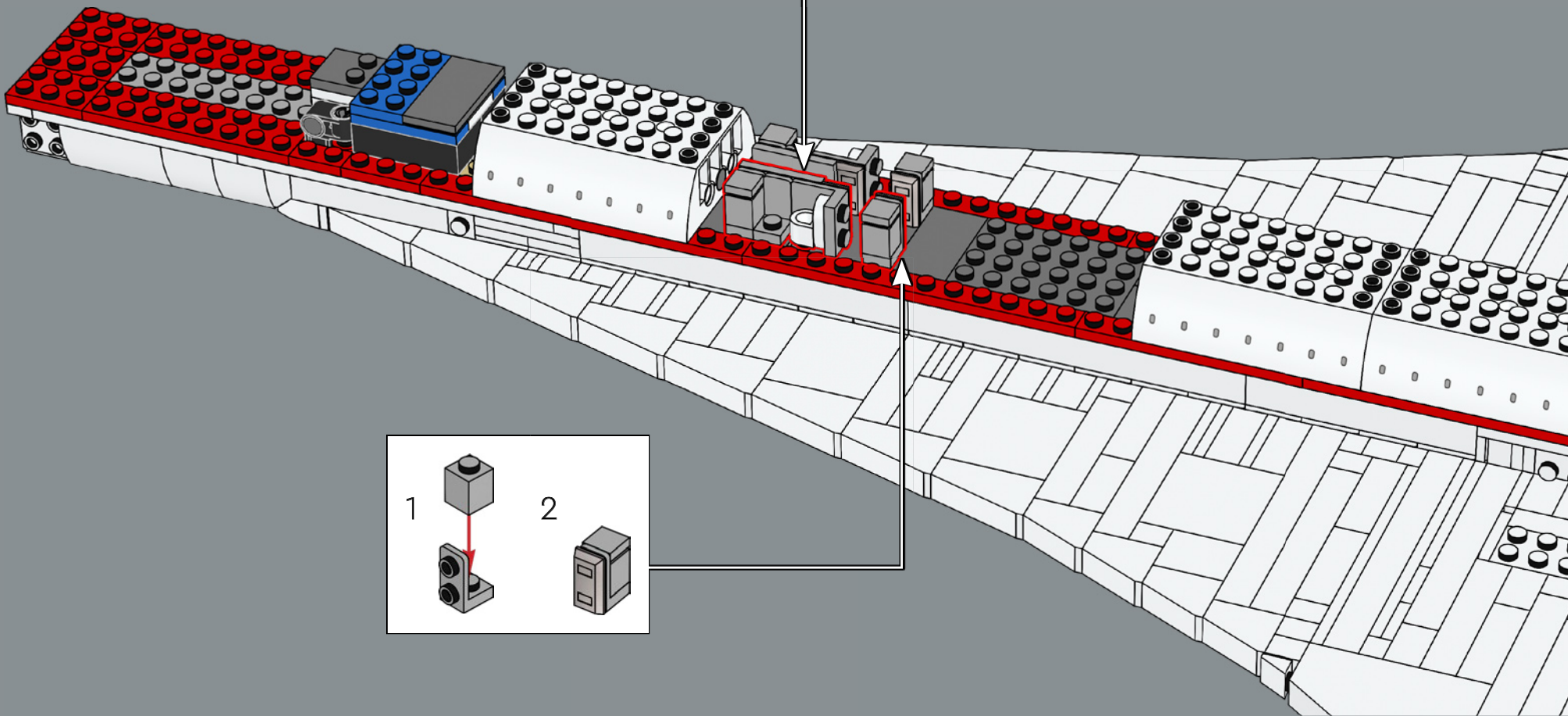
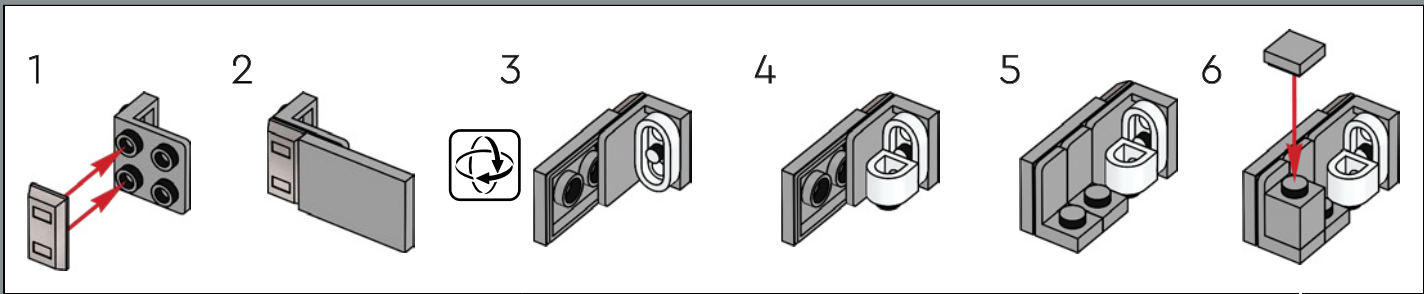



协和式飞机的 100 名乘客将享受豪华的设施和精致的美食，
在位于 18288 米 (60000 英尺) 高处的太空边缘欣赏令人惊
叹的景色。

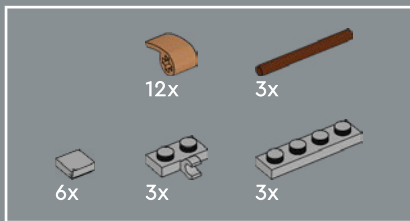

274

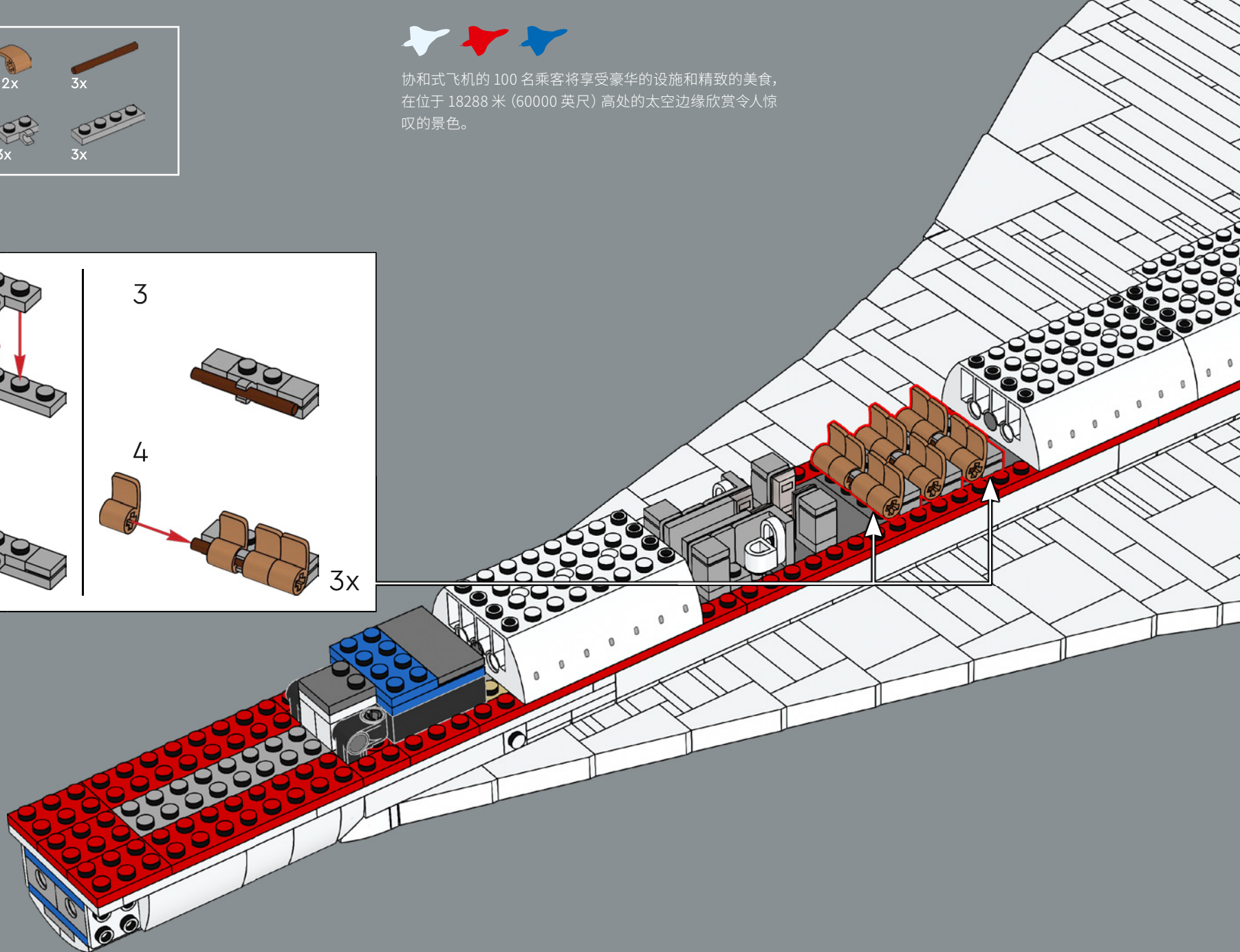
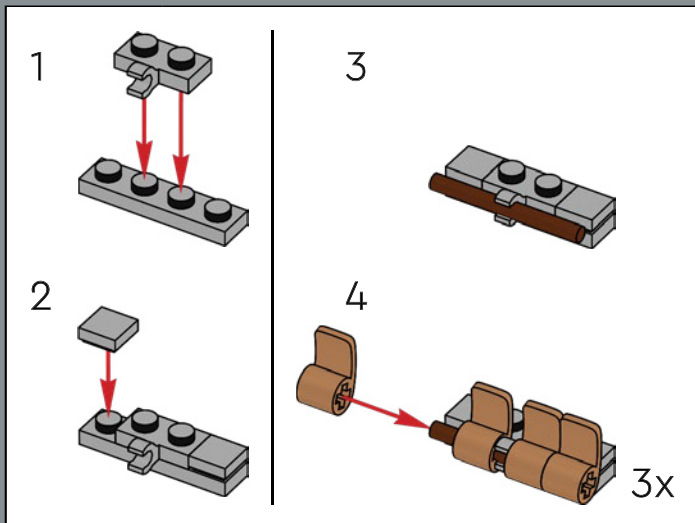

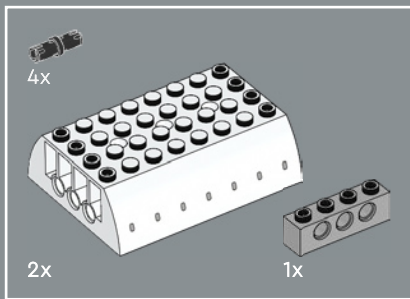

275

1

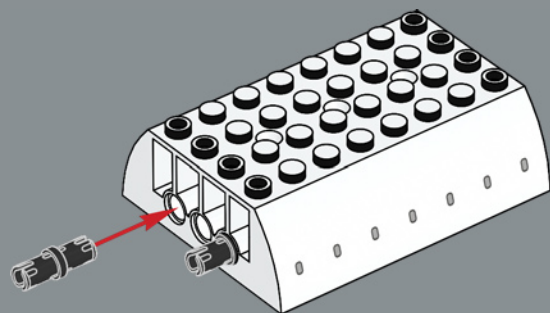

2

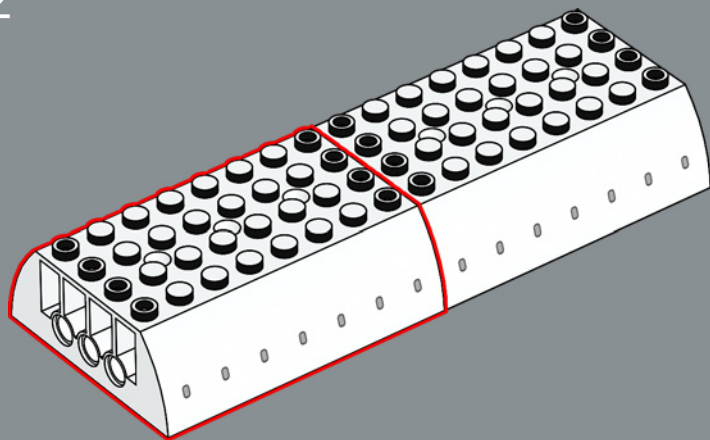

3

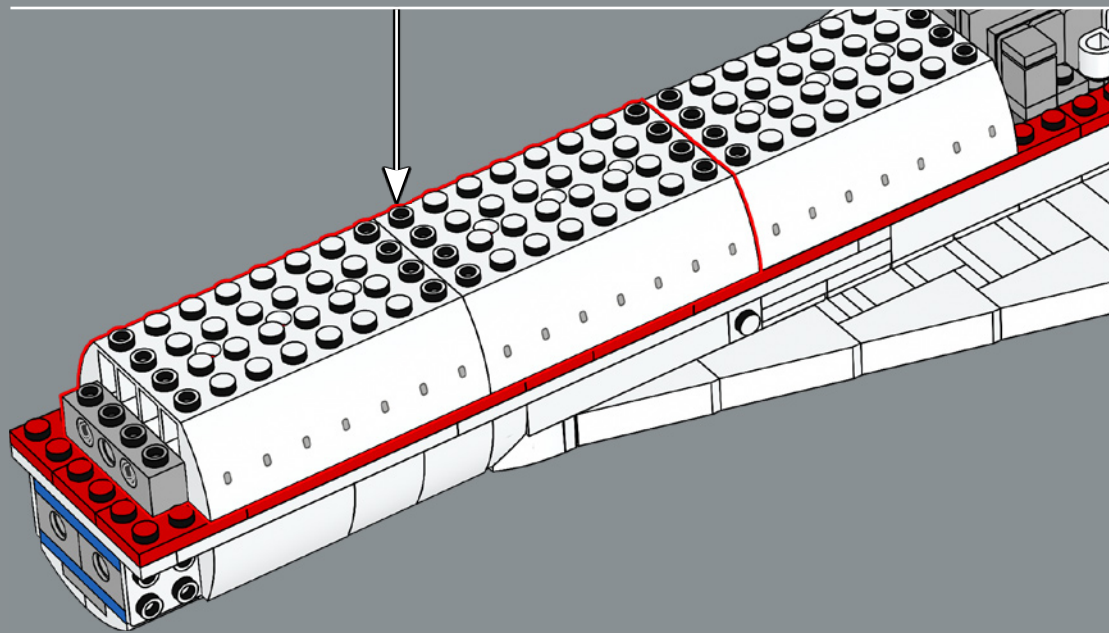
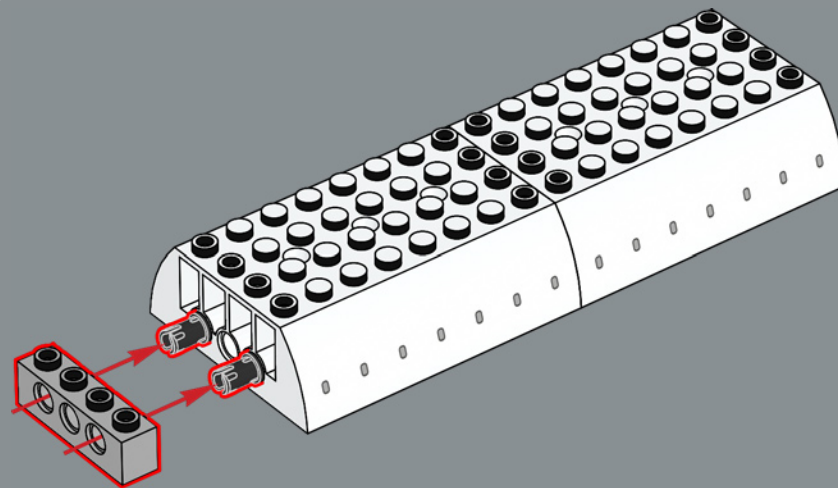

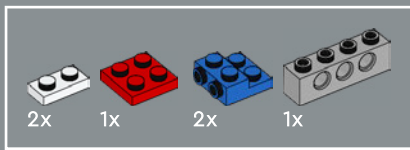

276

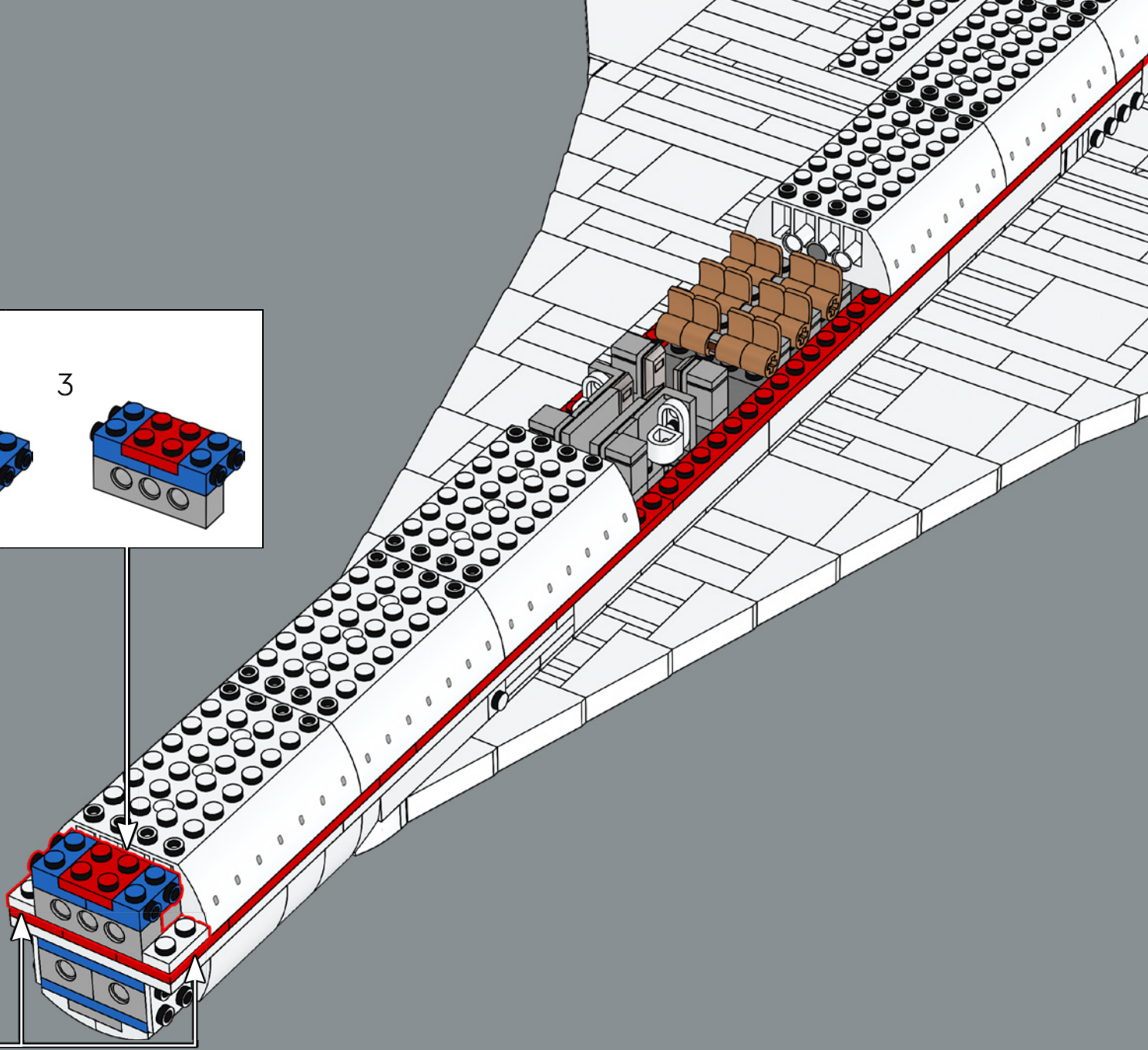
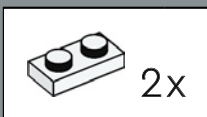
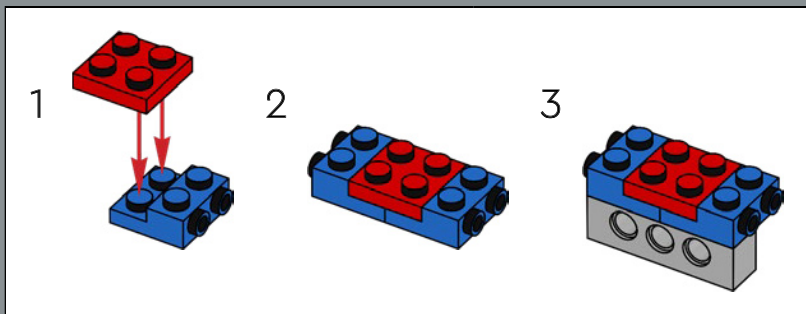

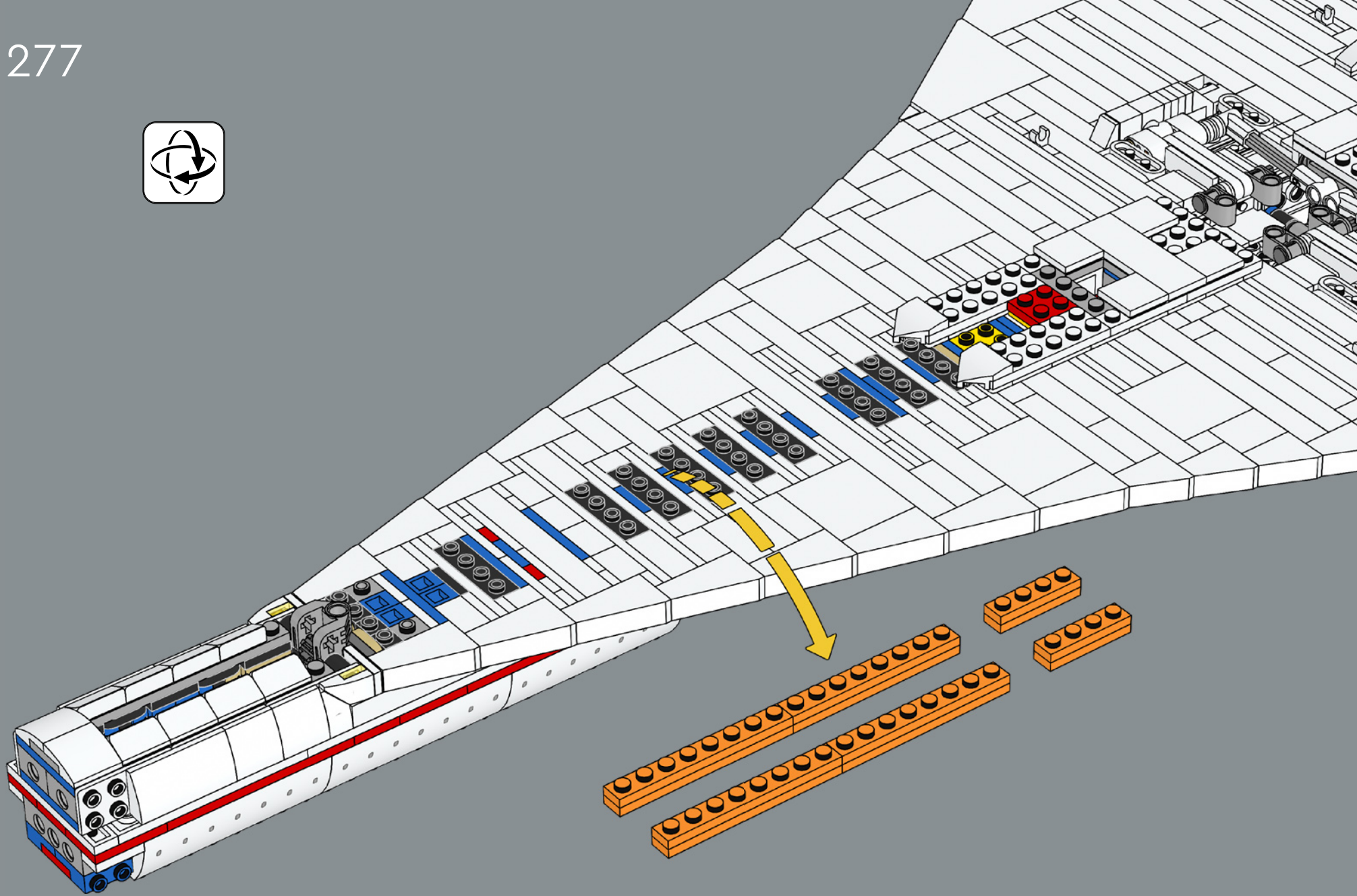

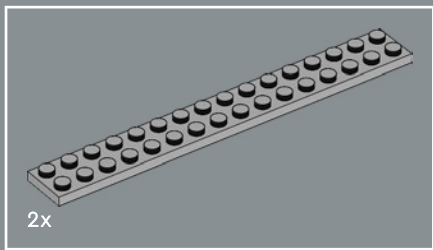

278

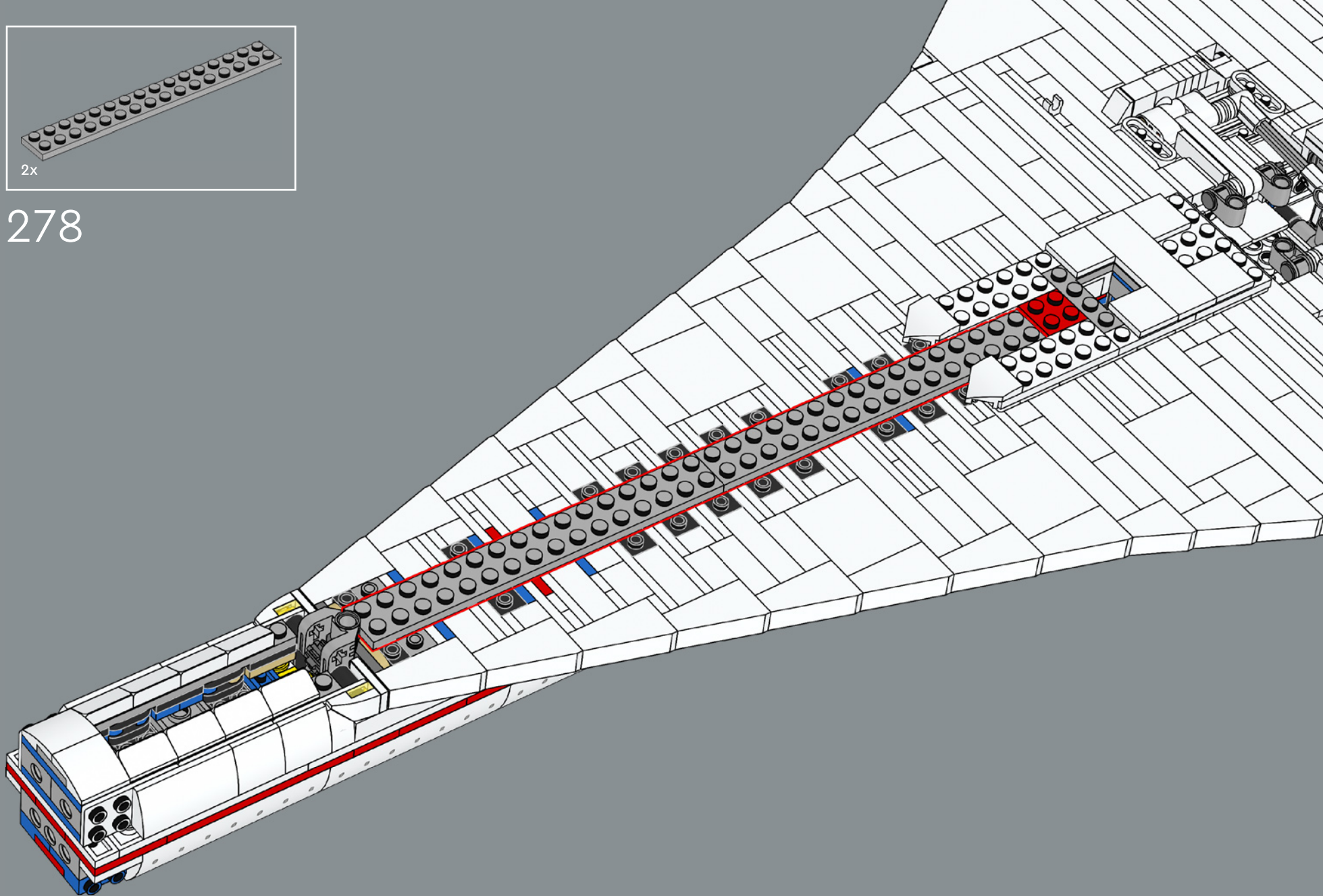

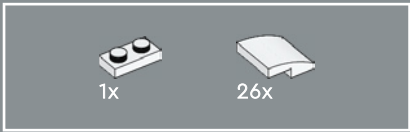

280

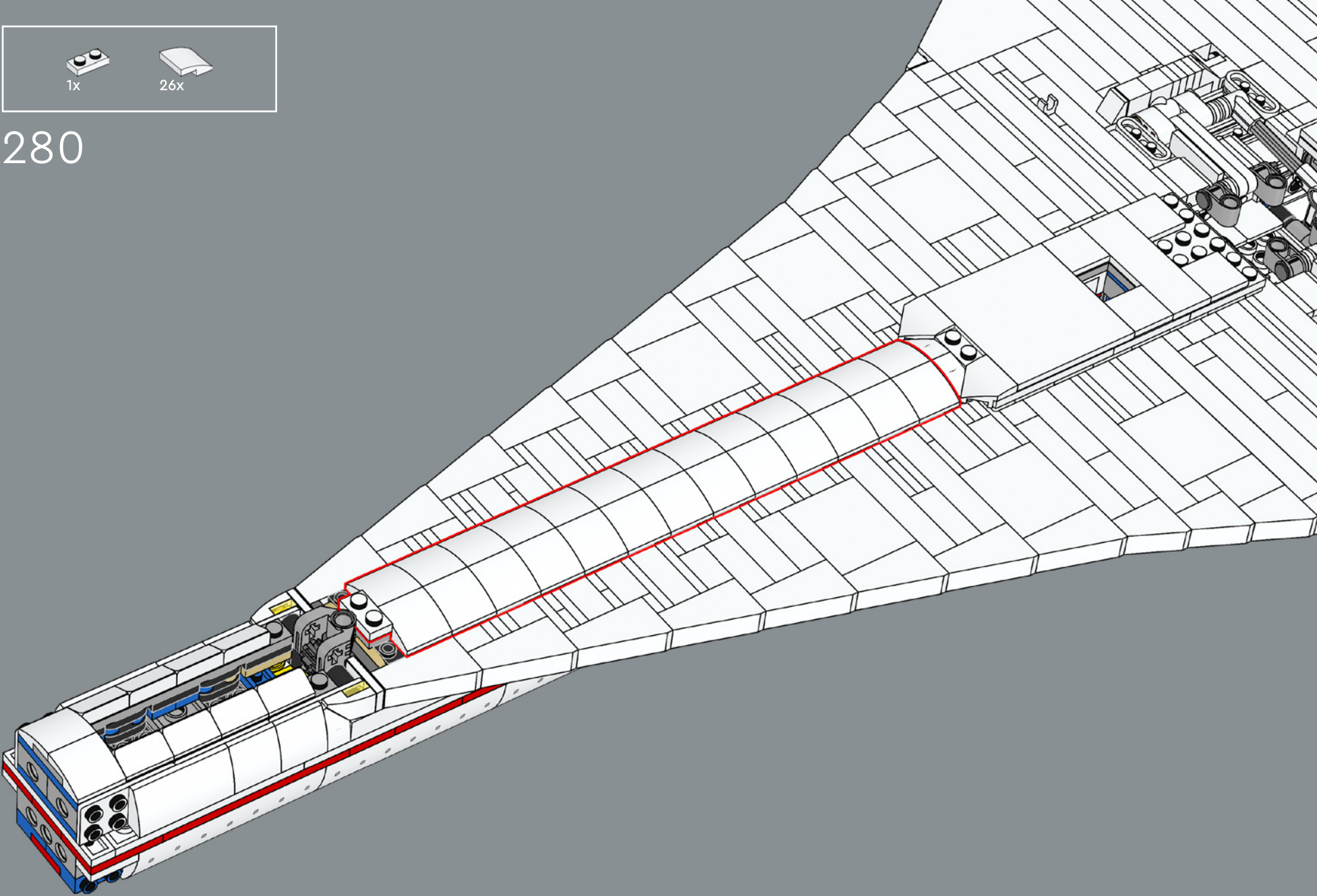



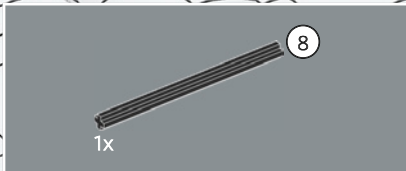

281

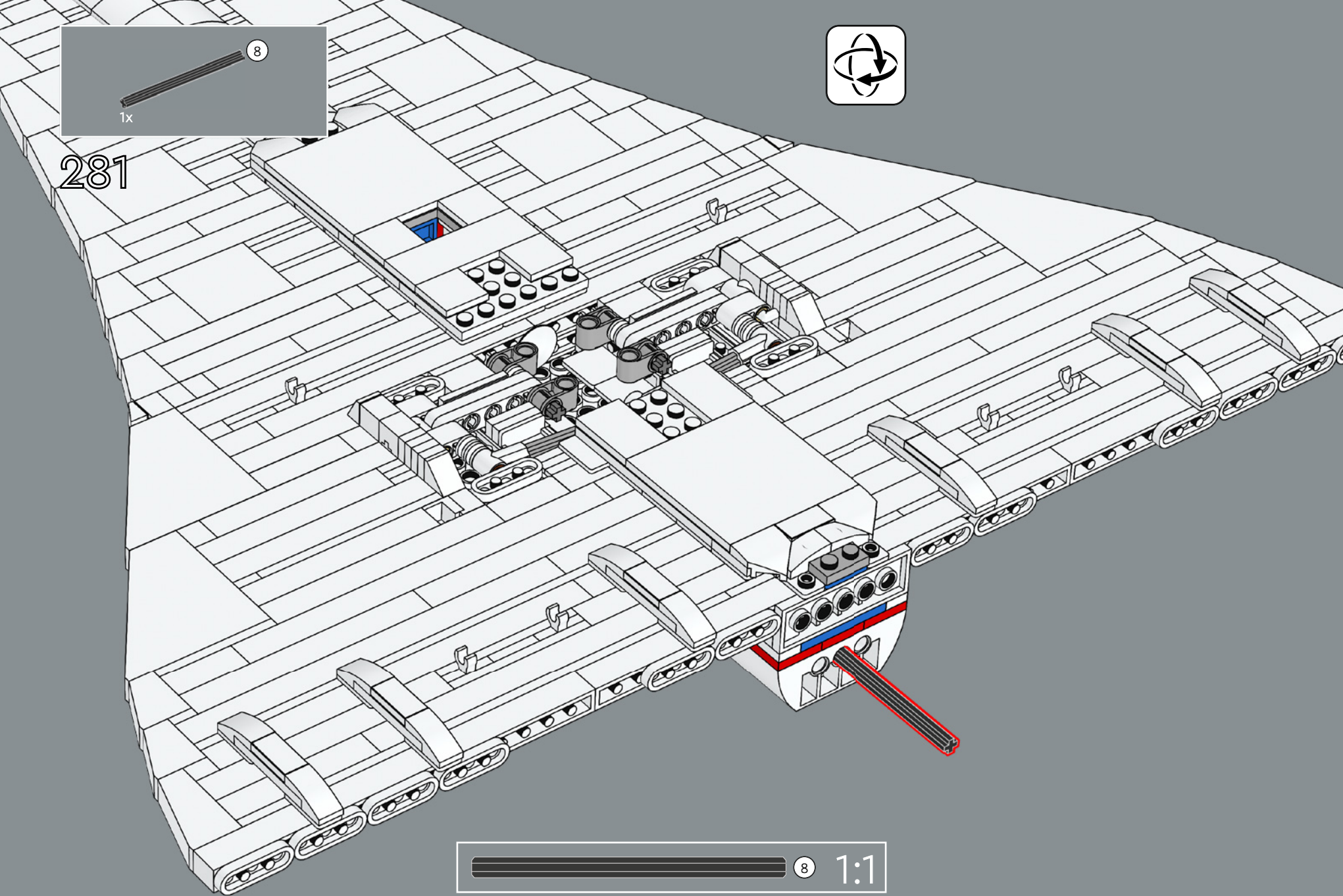

282

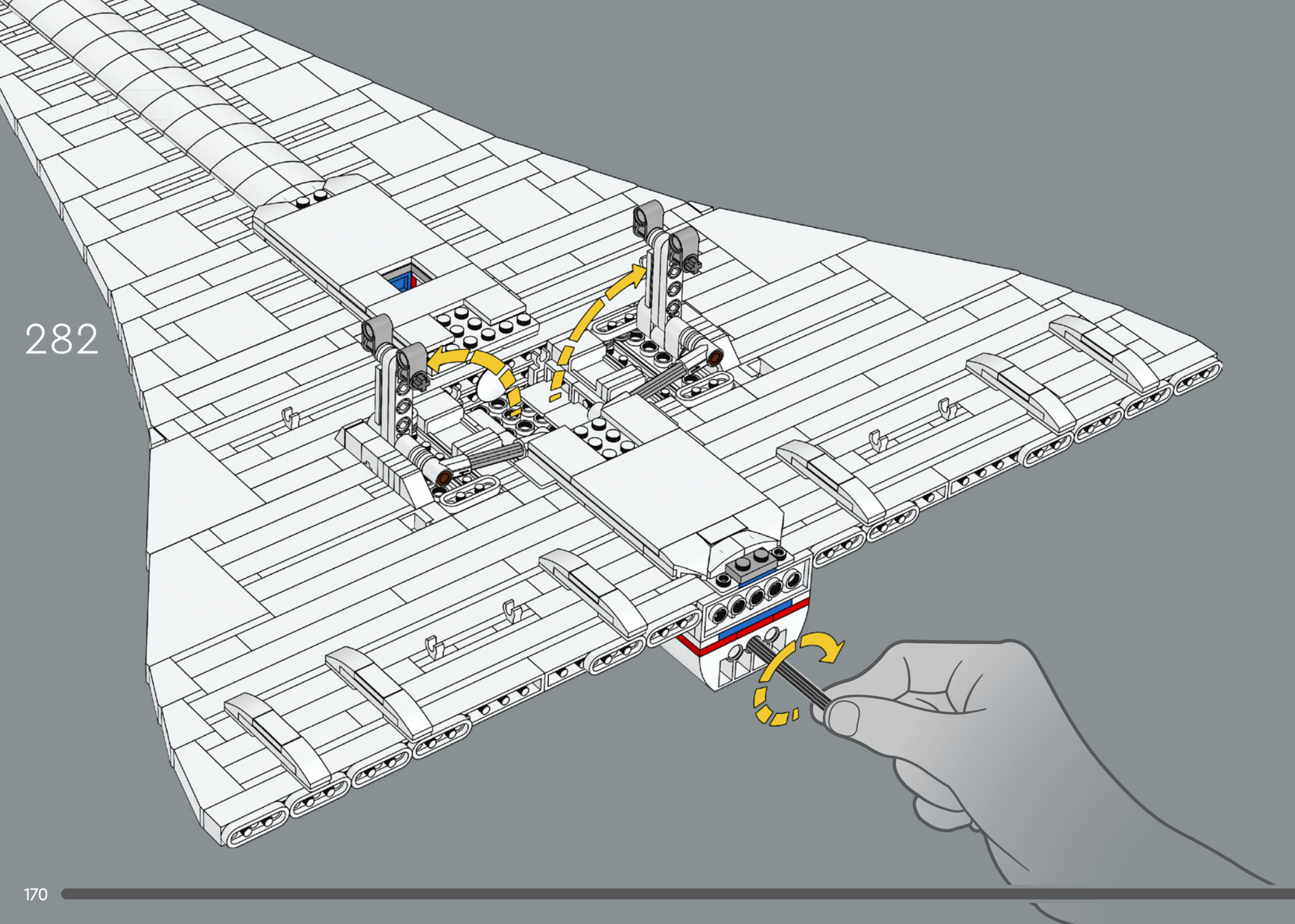



283

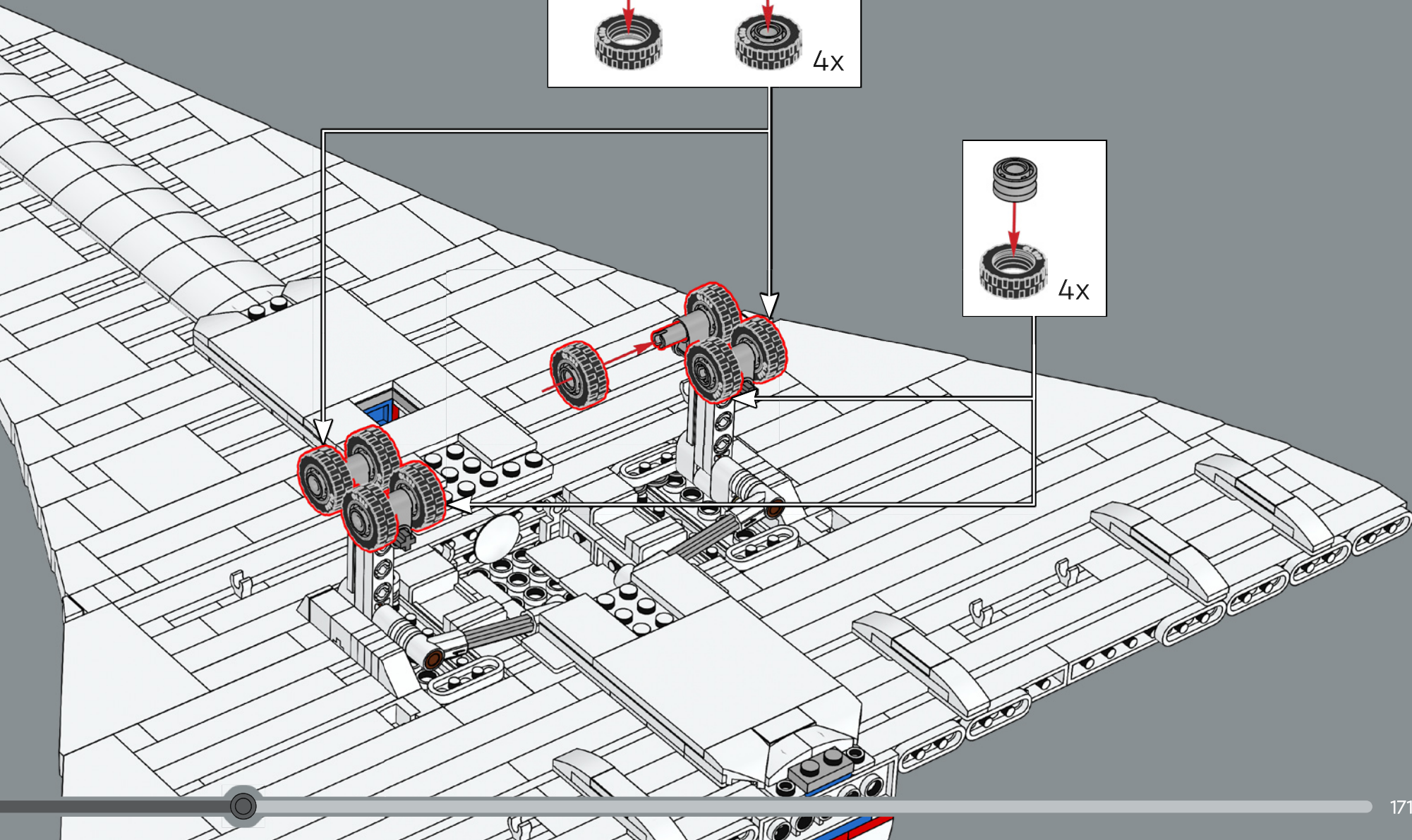
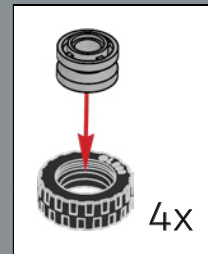
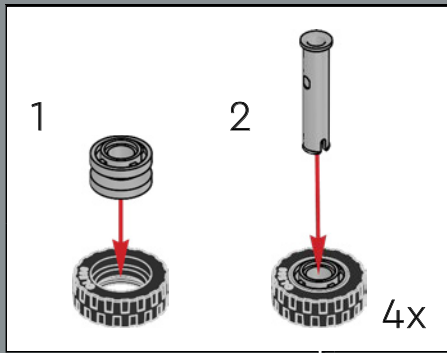



284

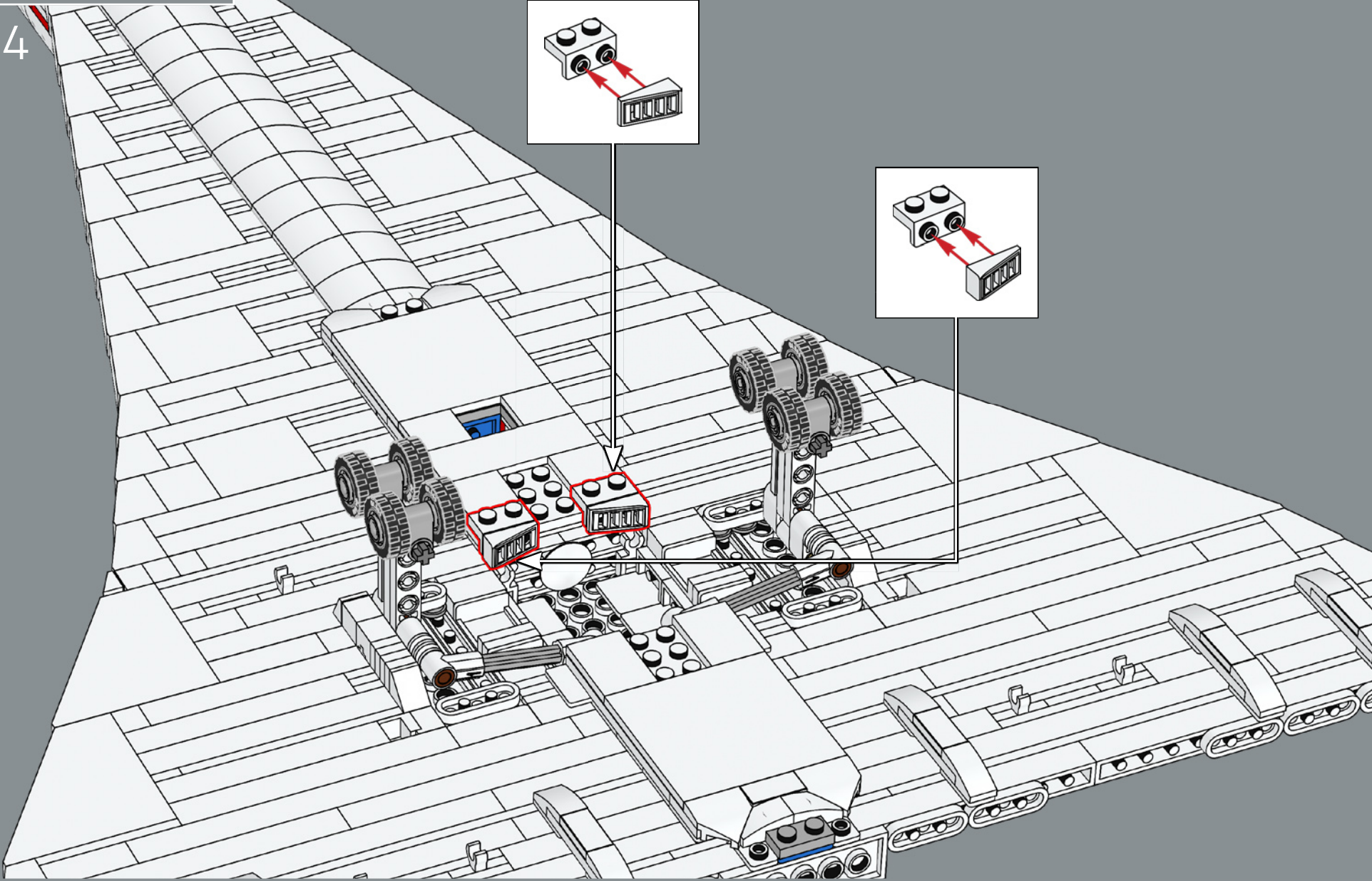
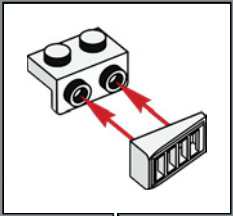
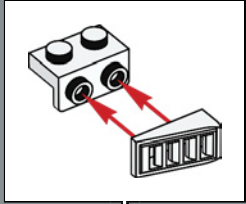

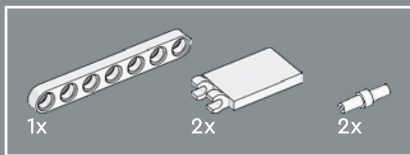

285

1

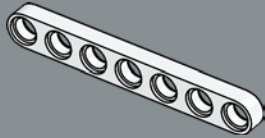

2

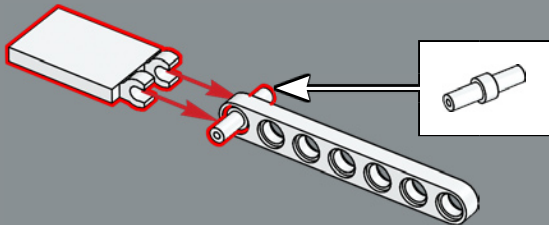

3

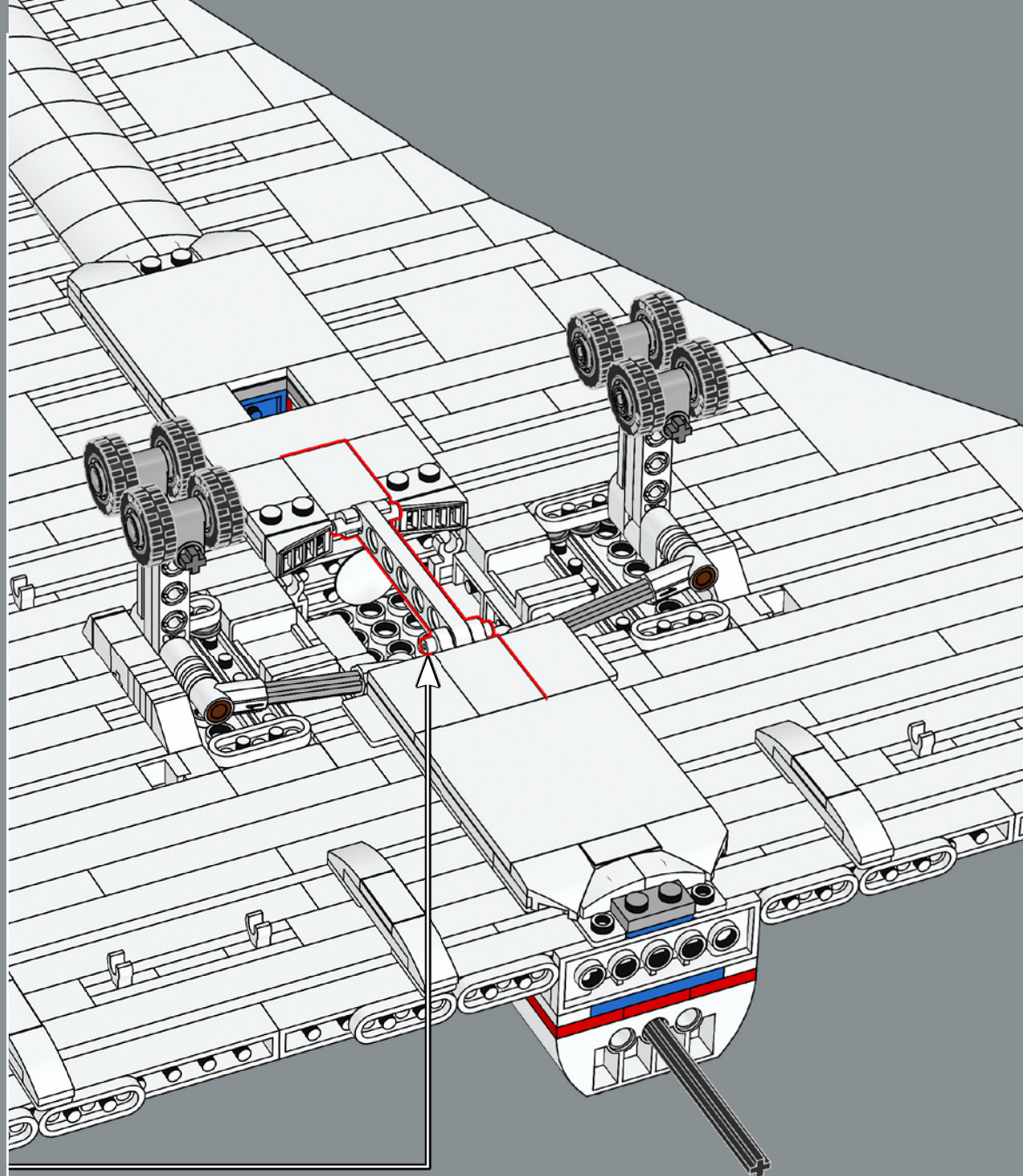
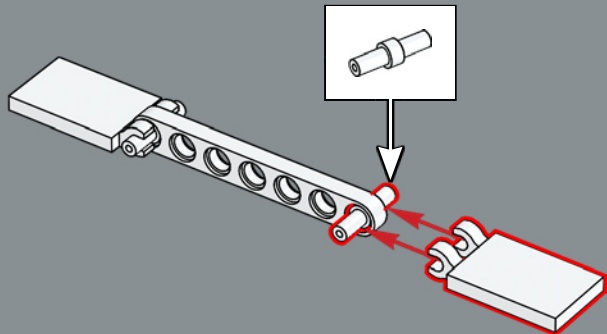

1x

286

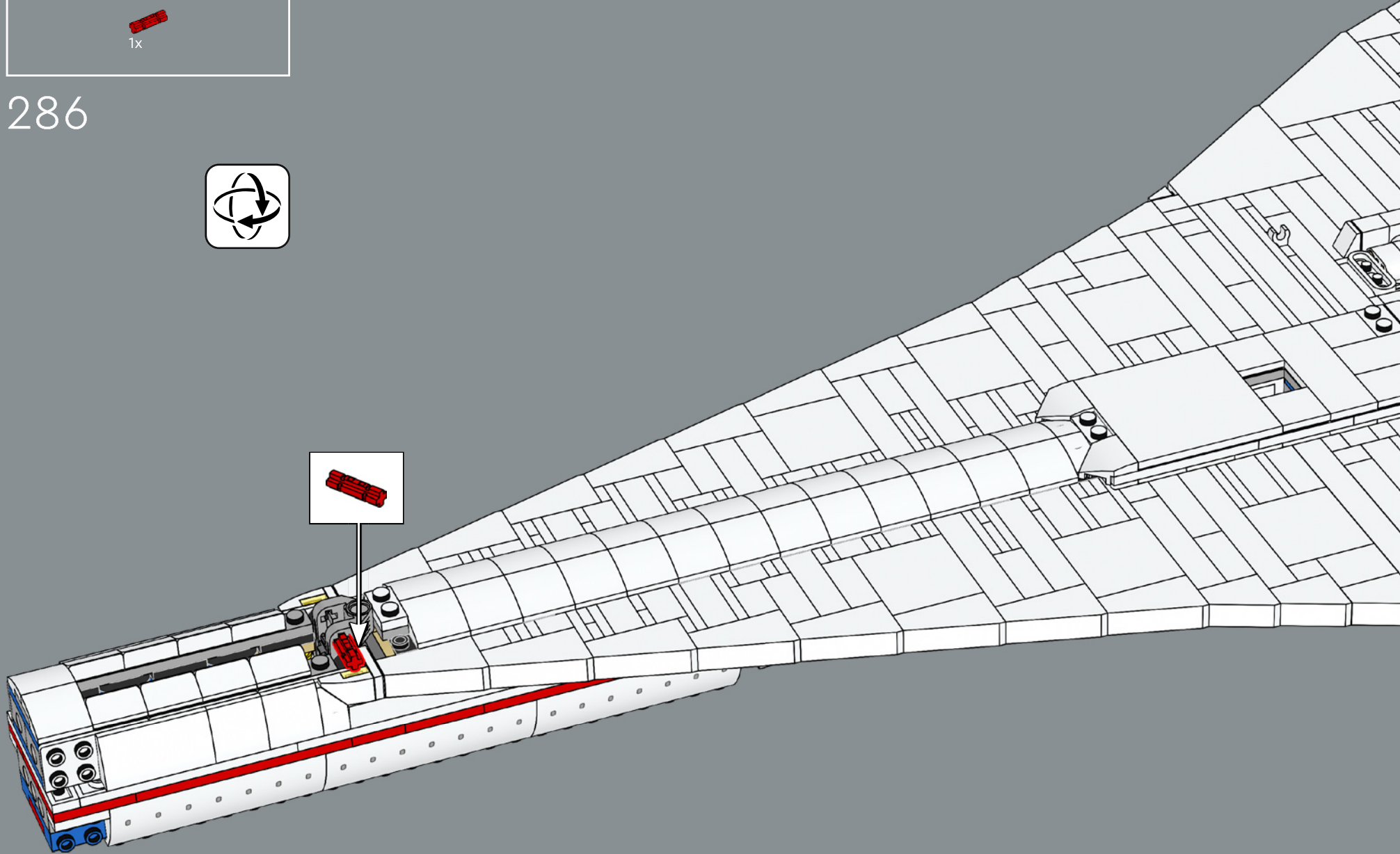

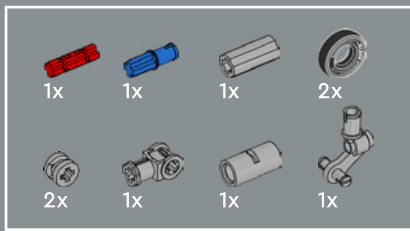

287

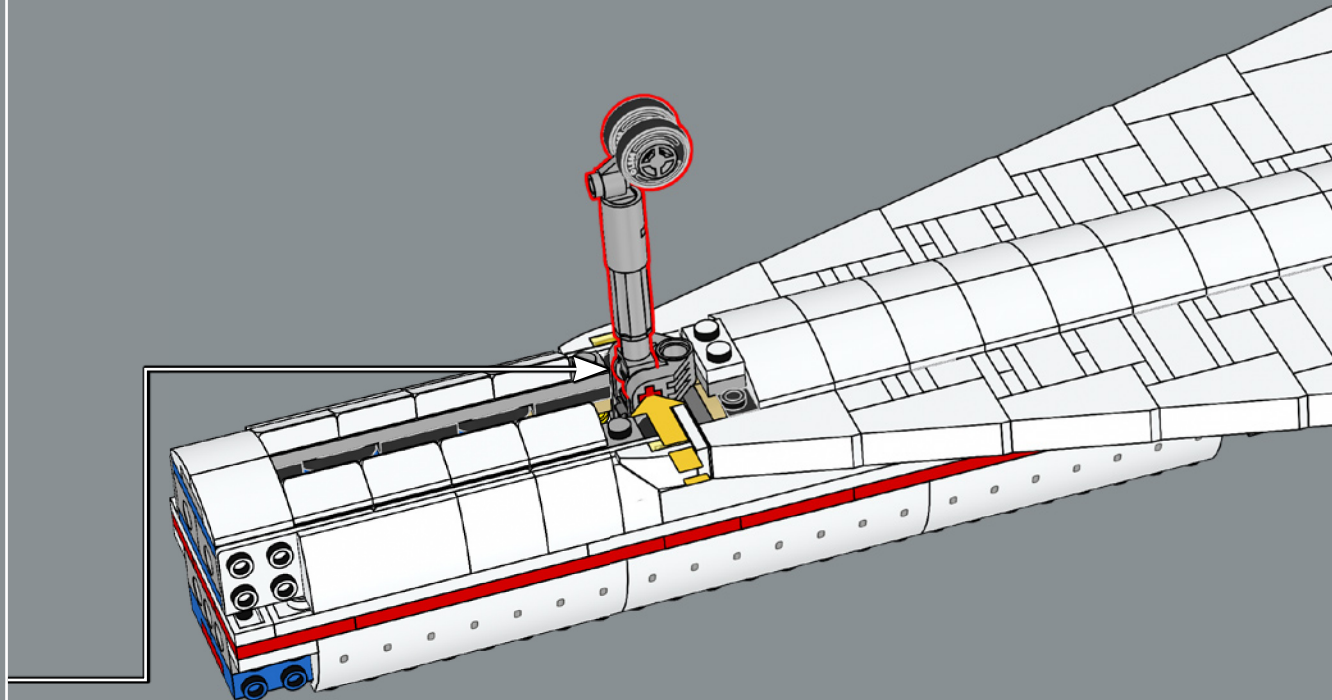
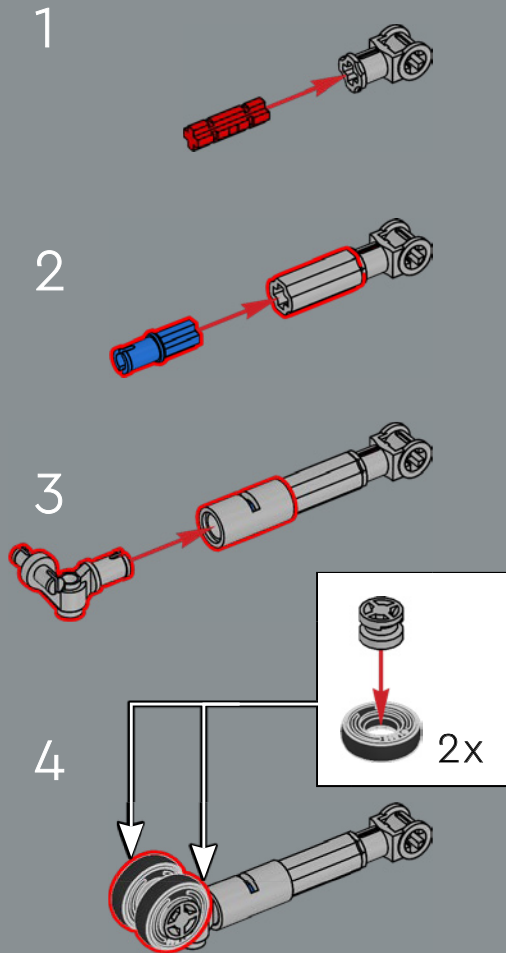

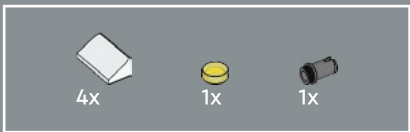

288

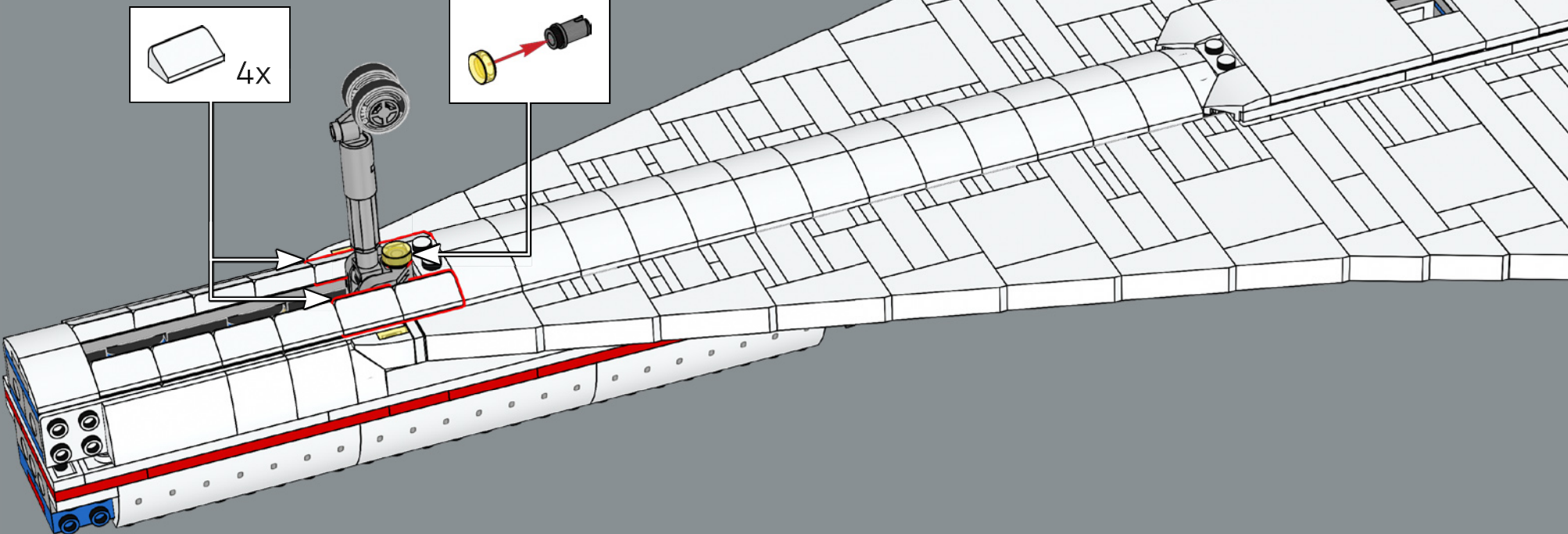

289

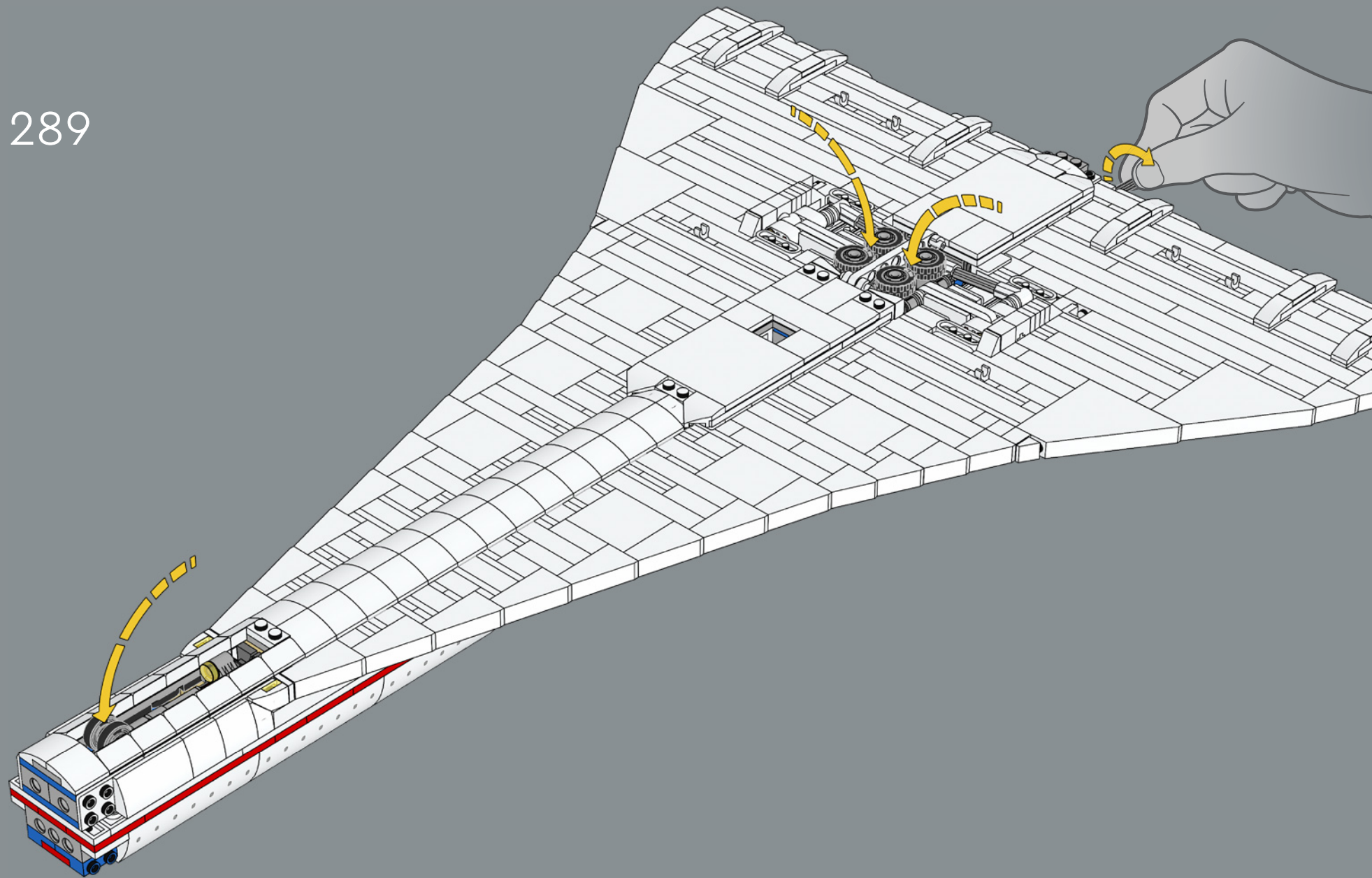

2x 6x

2x

290

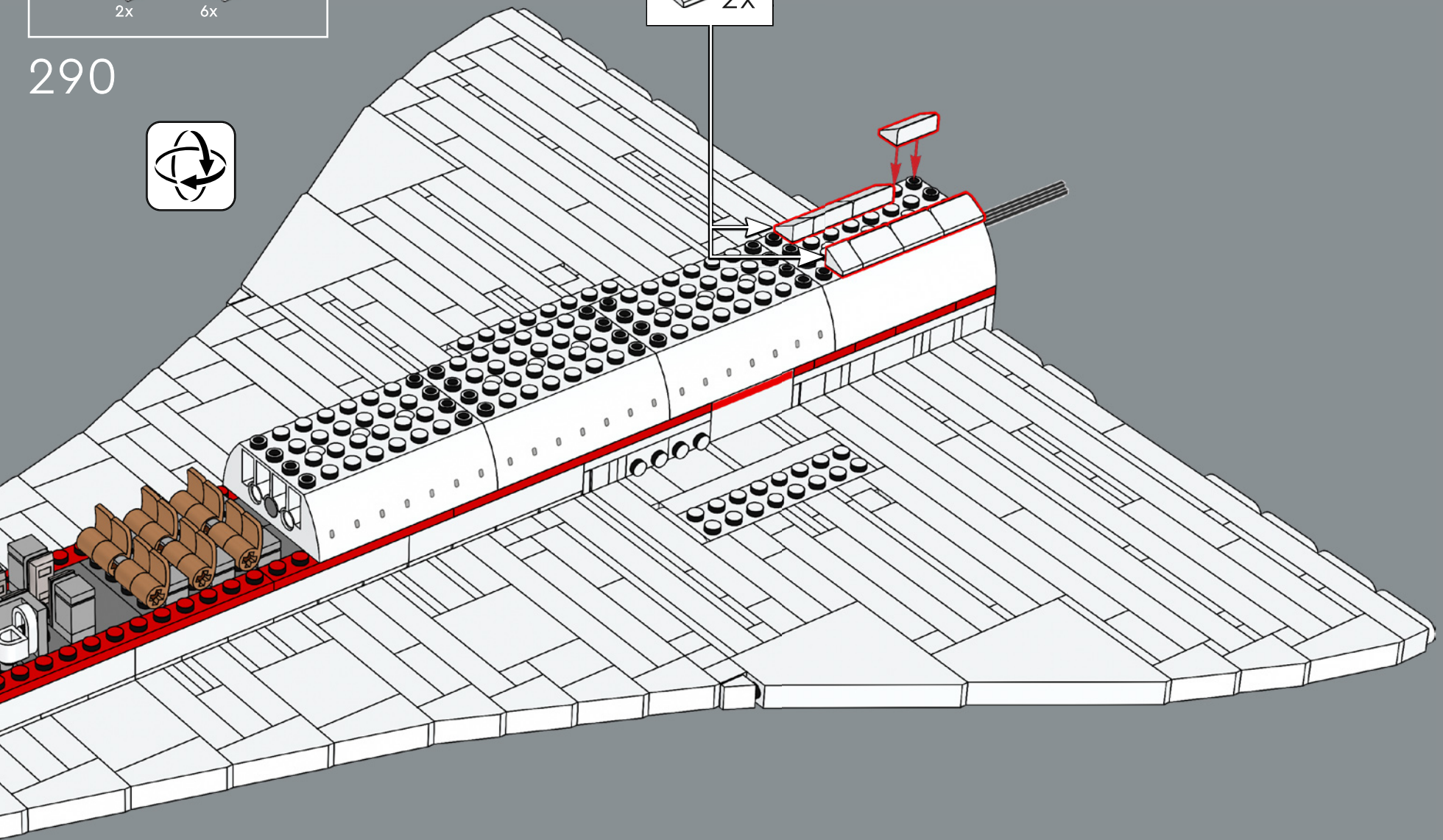

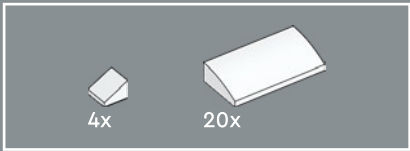

292

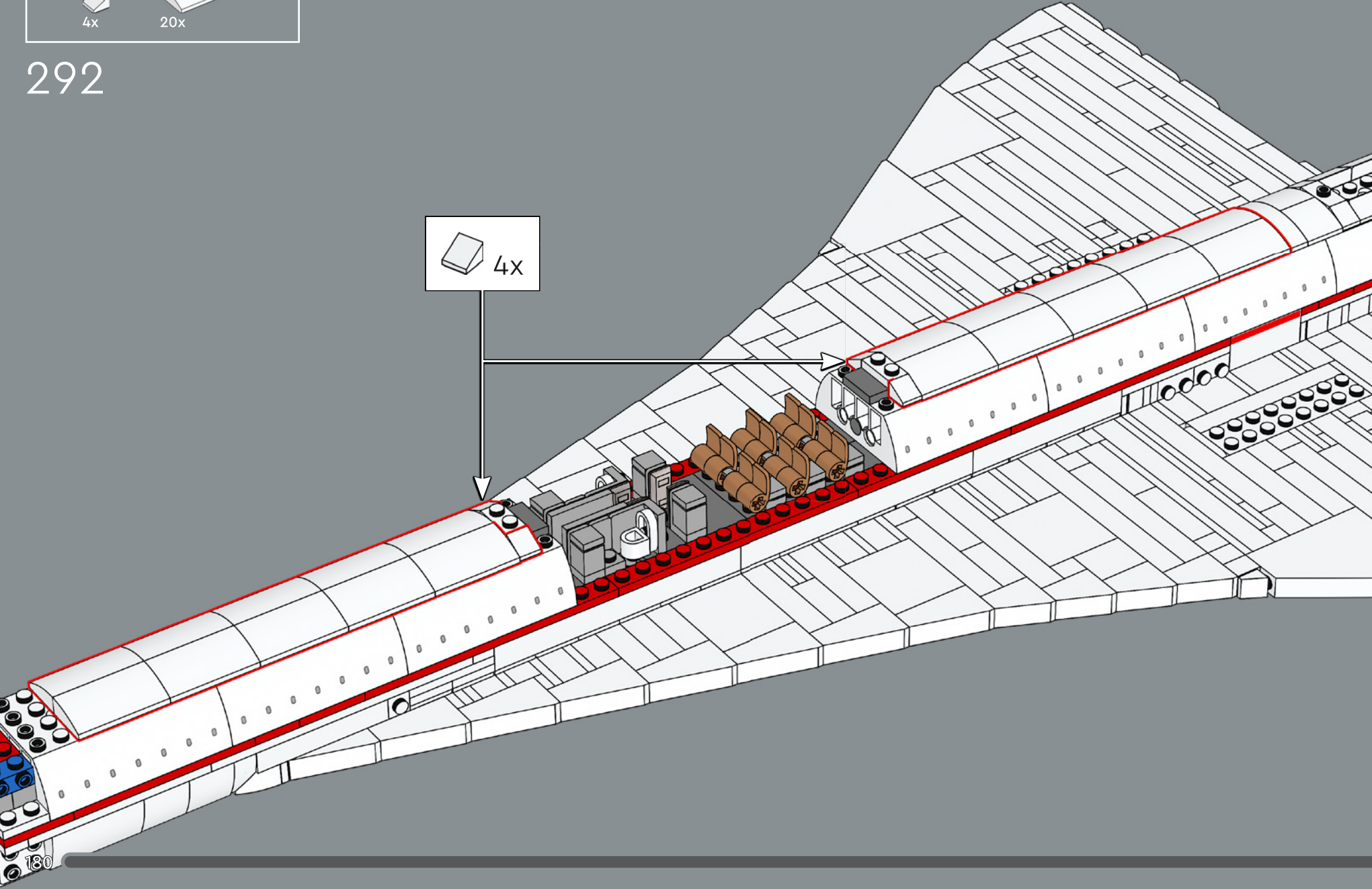
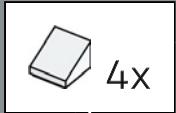

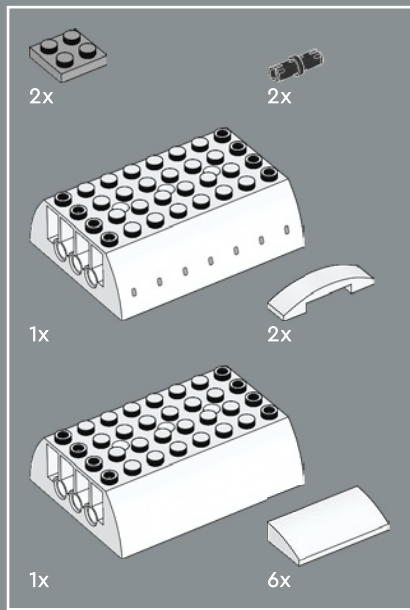

1

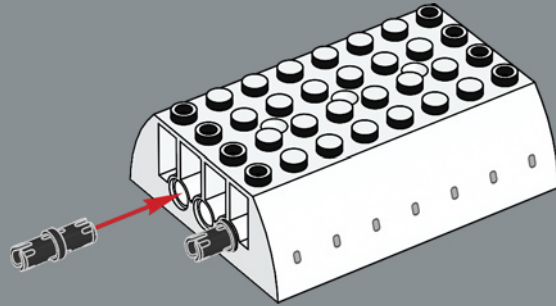

3

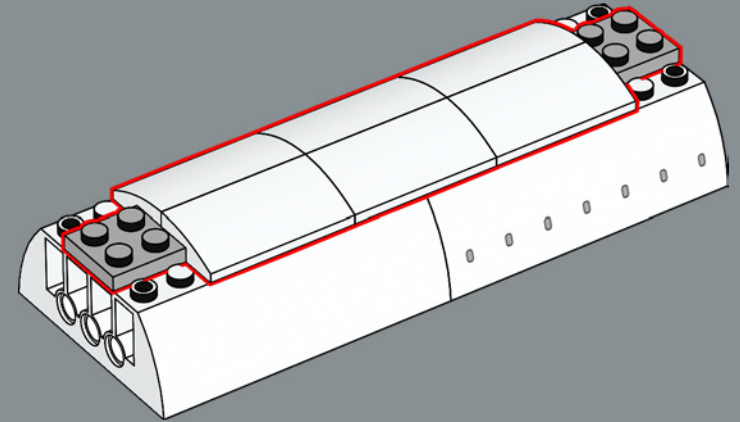

293

2

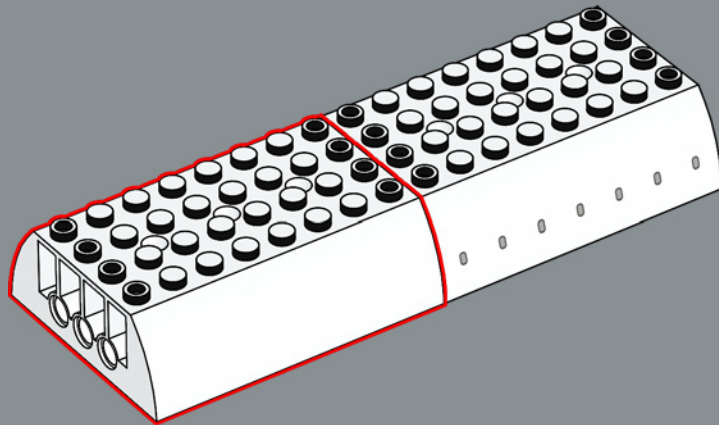

4

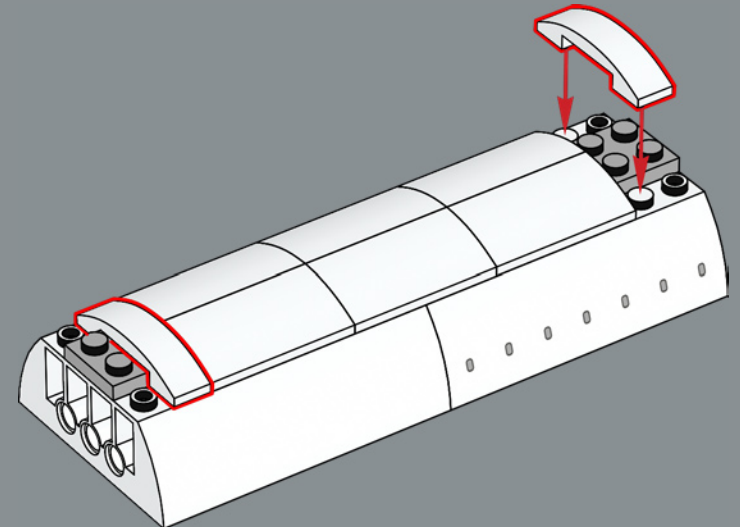

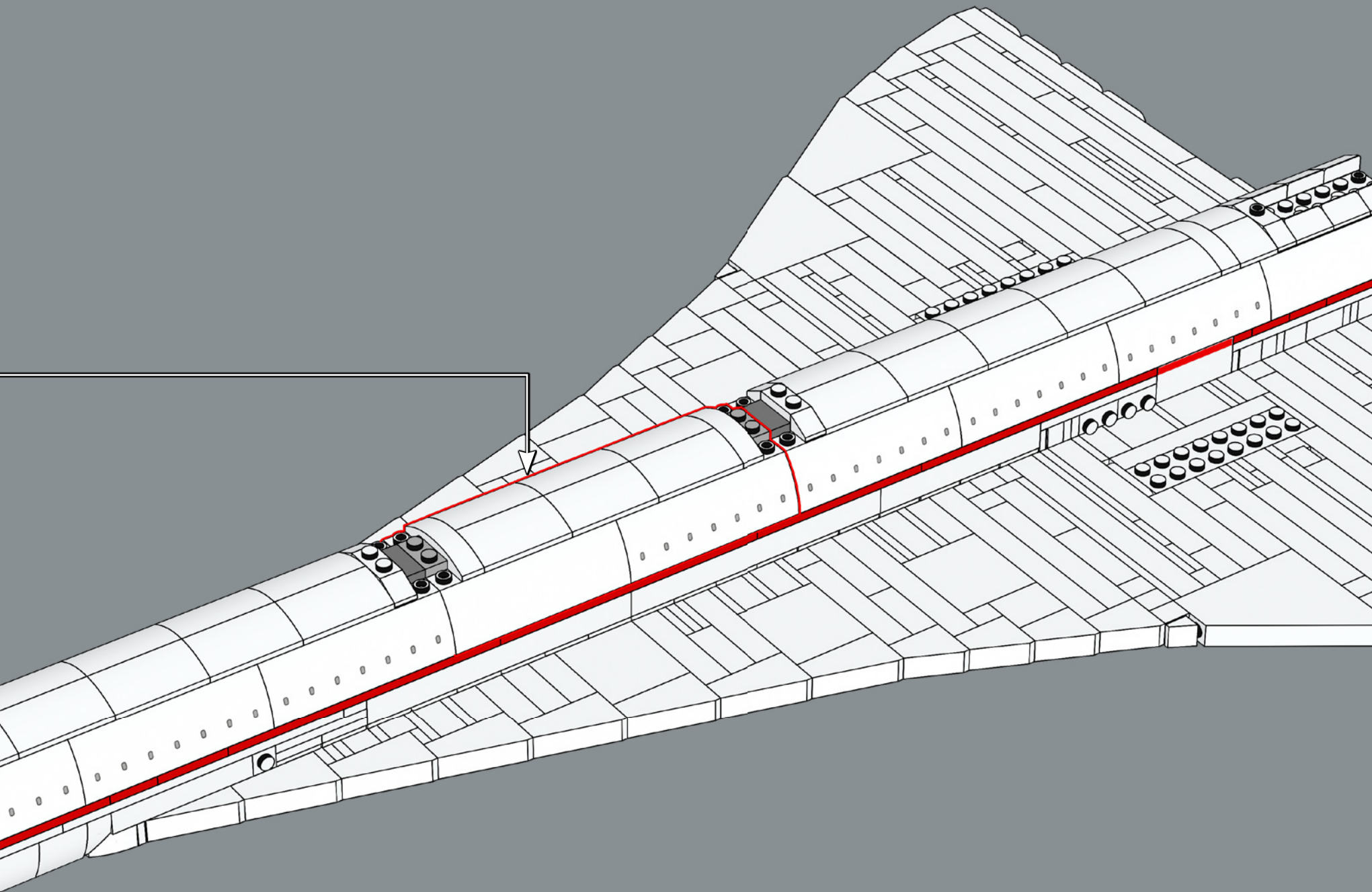



294



拆下机身的中间部分，显露出后舱的一部分，其中乘客座椅的设计灵感来自 20 世纪 70 年代的原始设计。

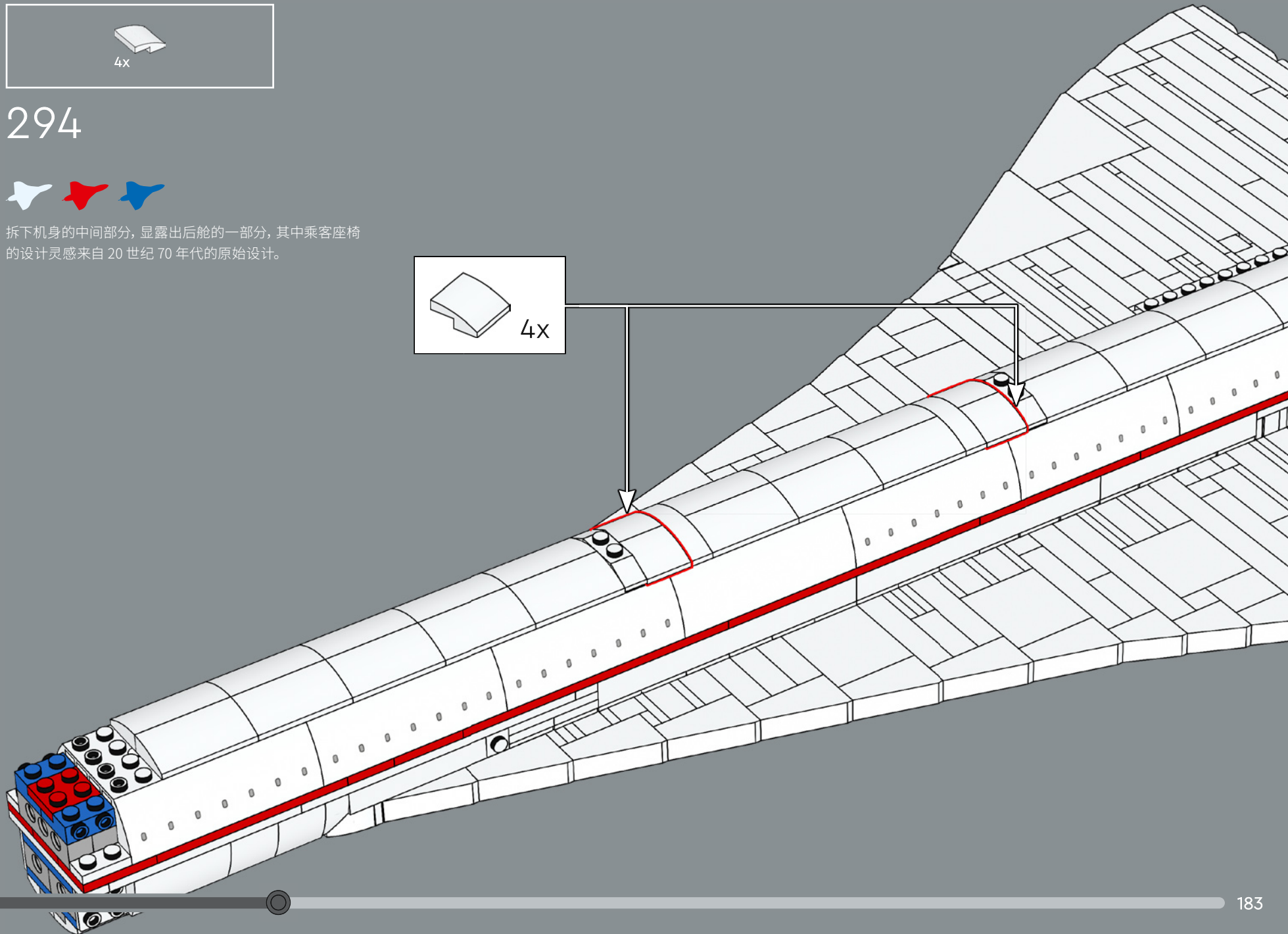
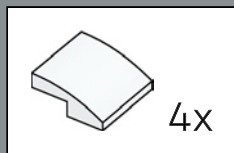

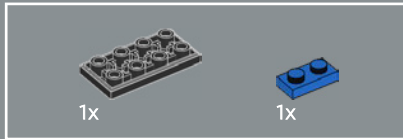
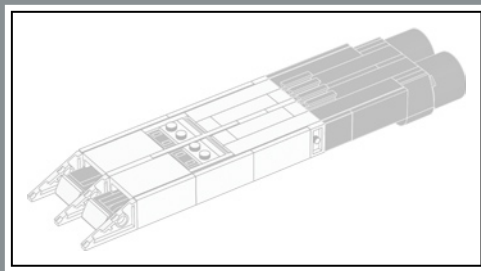

295

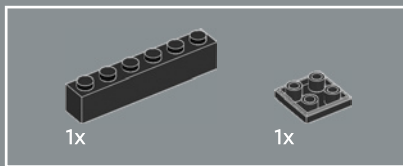
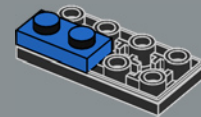

296

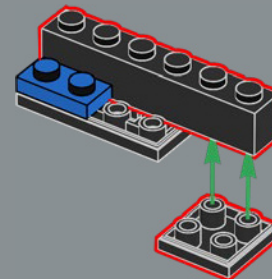

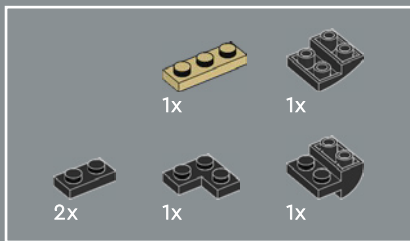

297

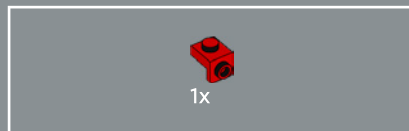
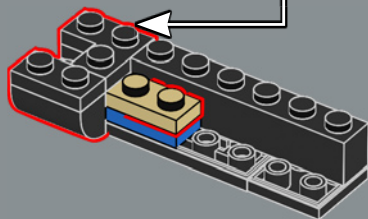
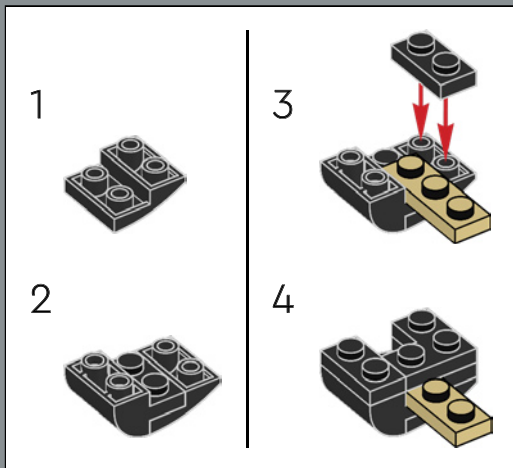

298

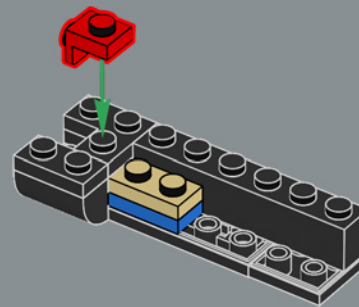

299

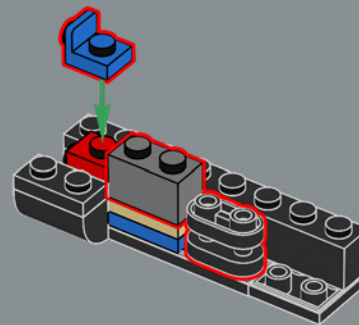

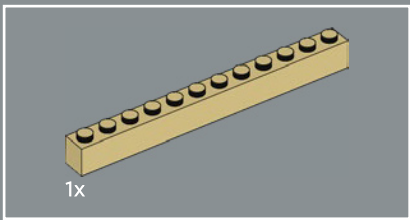

300

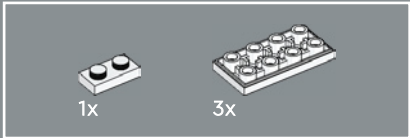
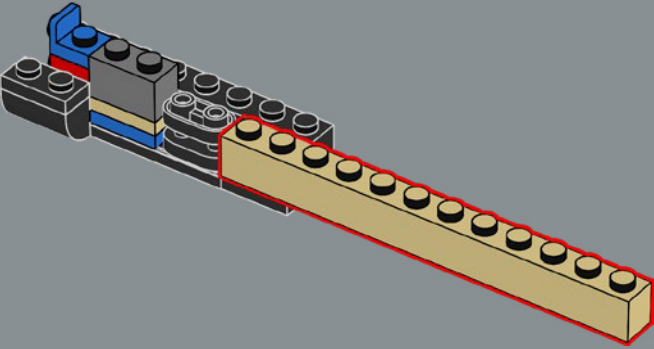

301

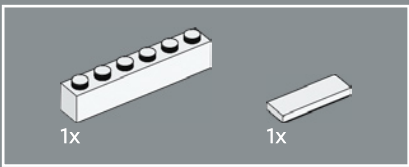
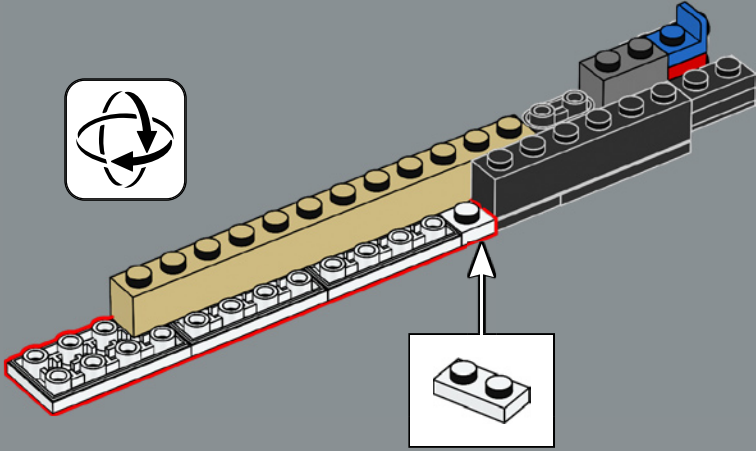

302

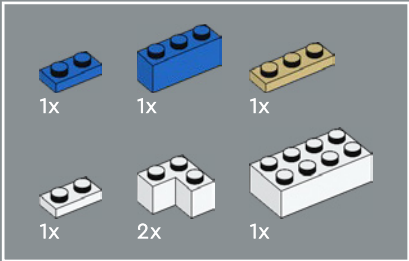
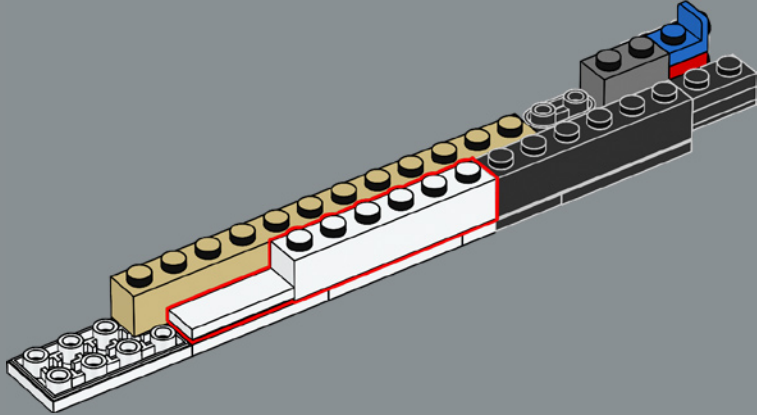

303

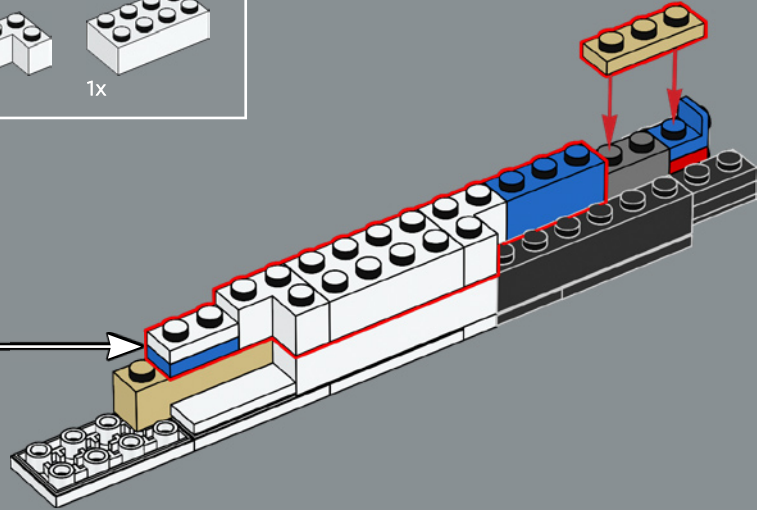
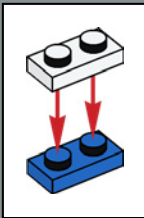

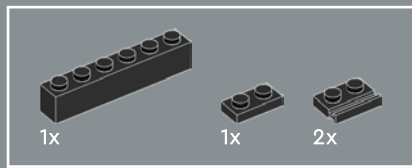

304

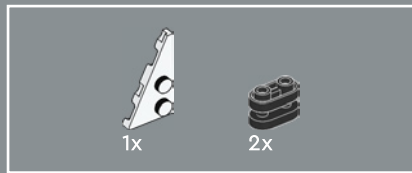
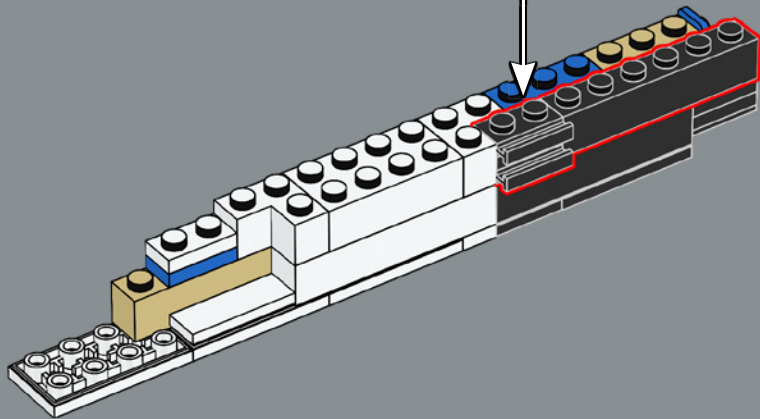
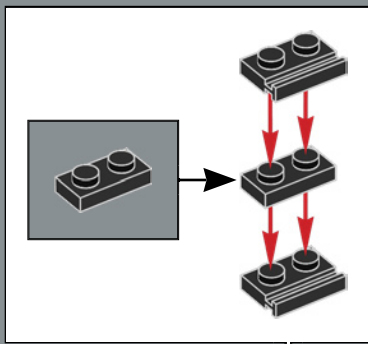

305

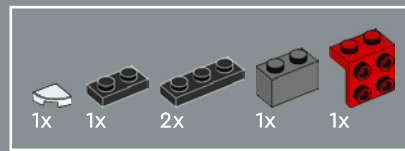
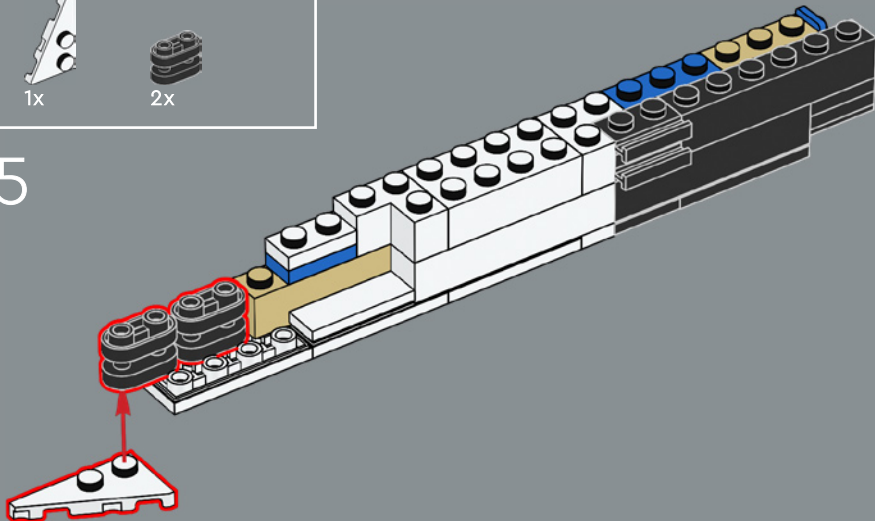

306

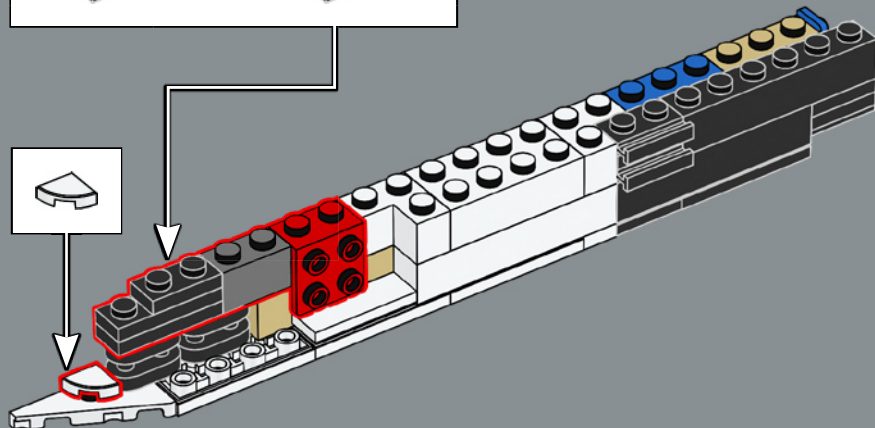
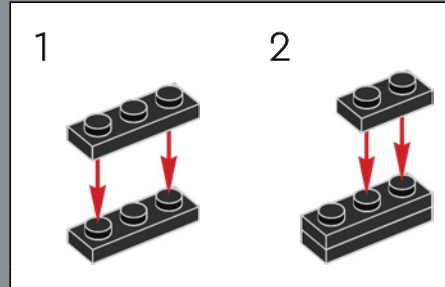

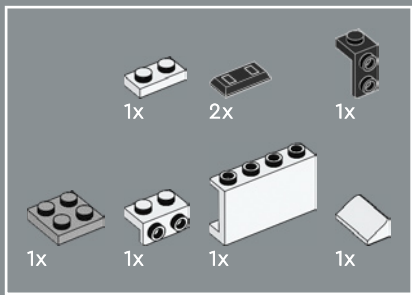

307

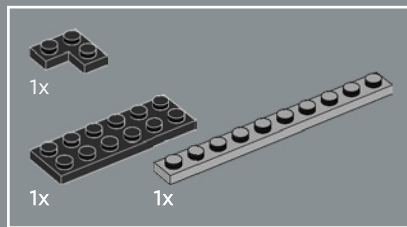
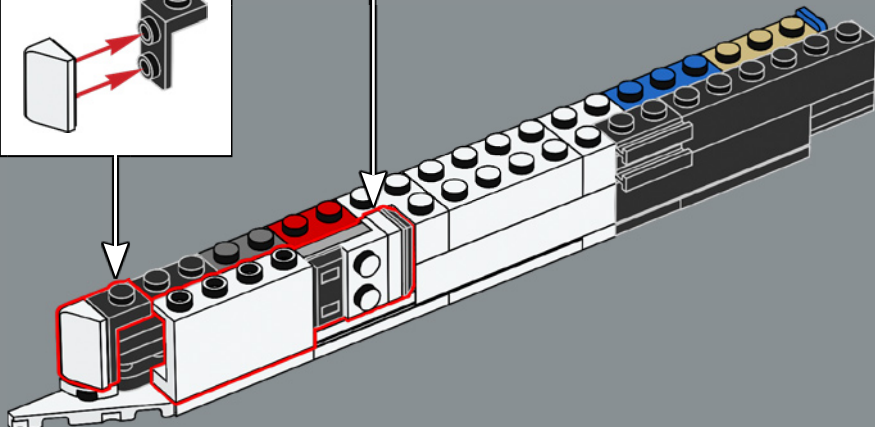
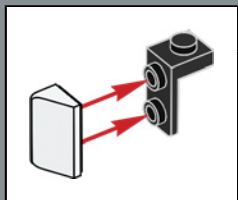
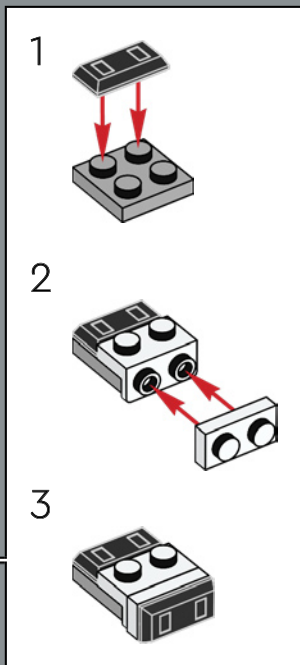

308

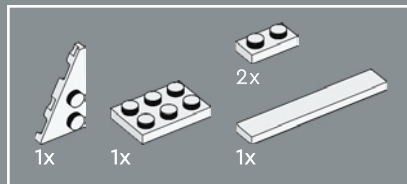
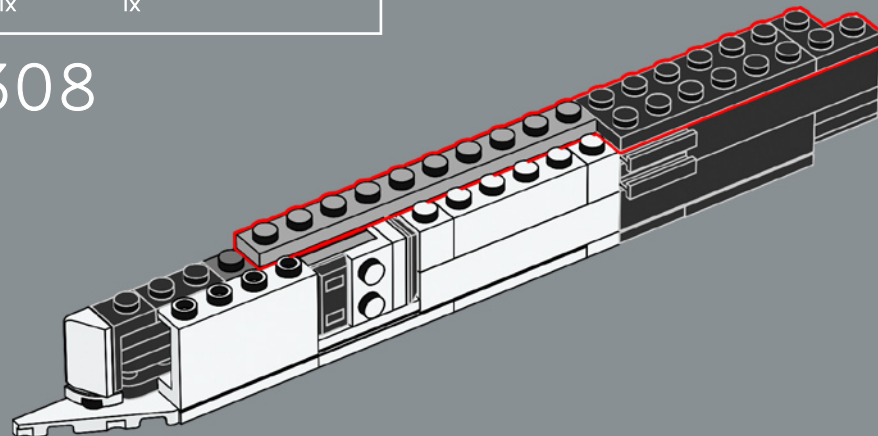

309

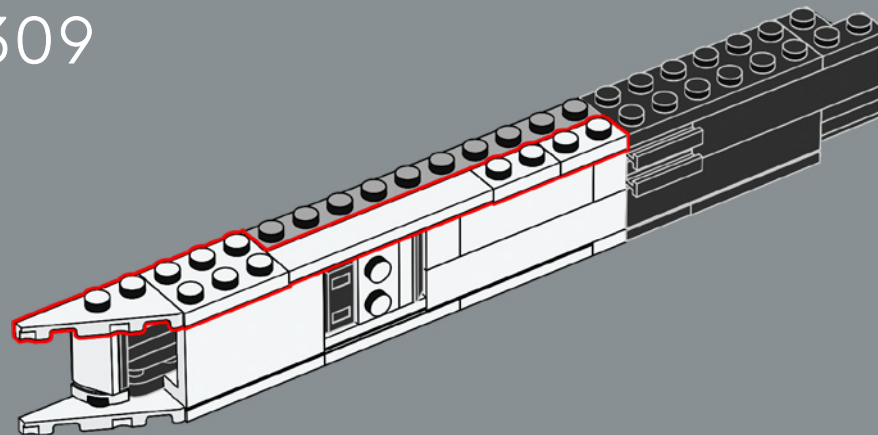

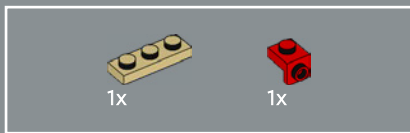

310

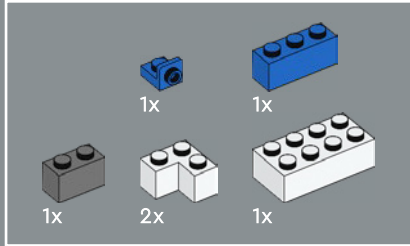
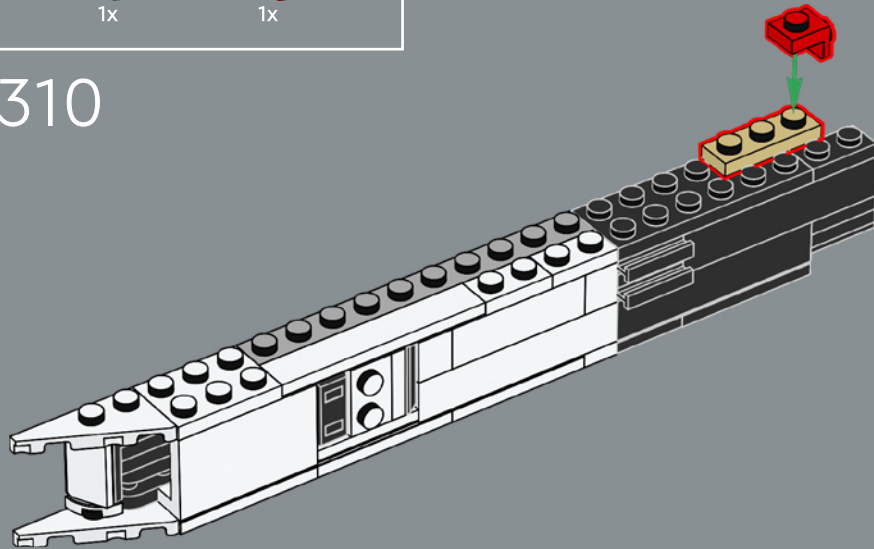

311

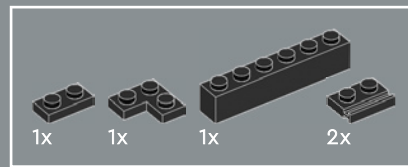
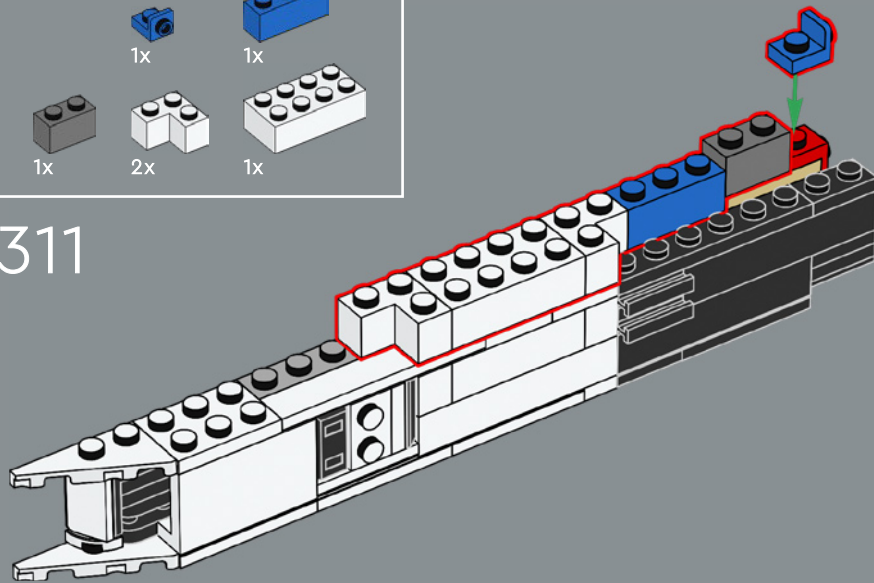

312

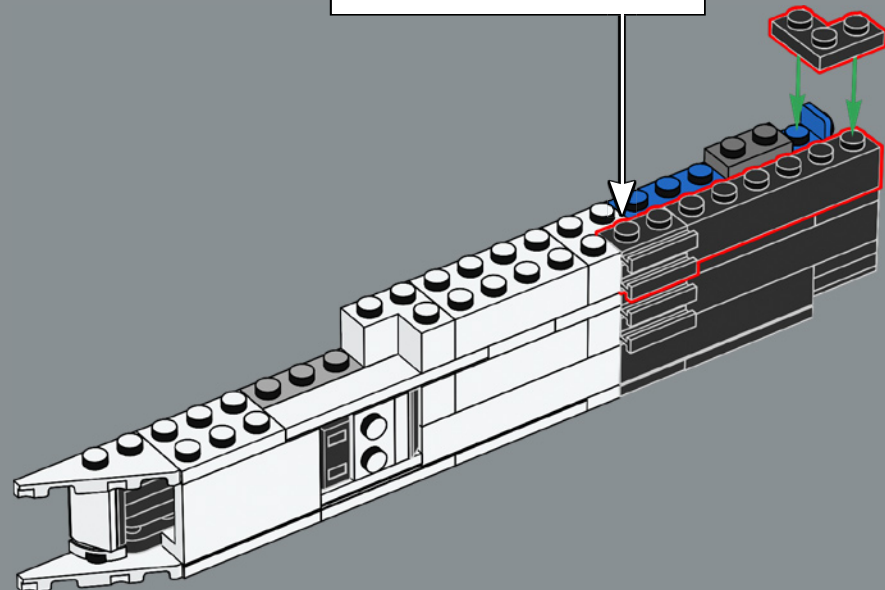
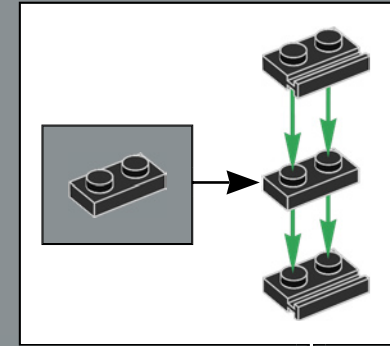

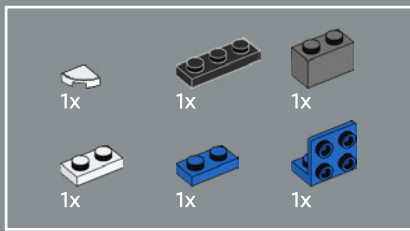

313

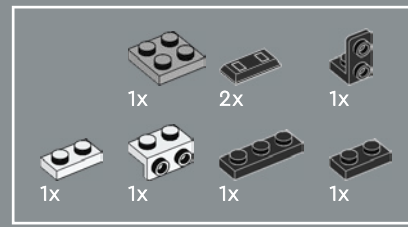
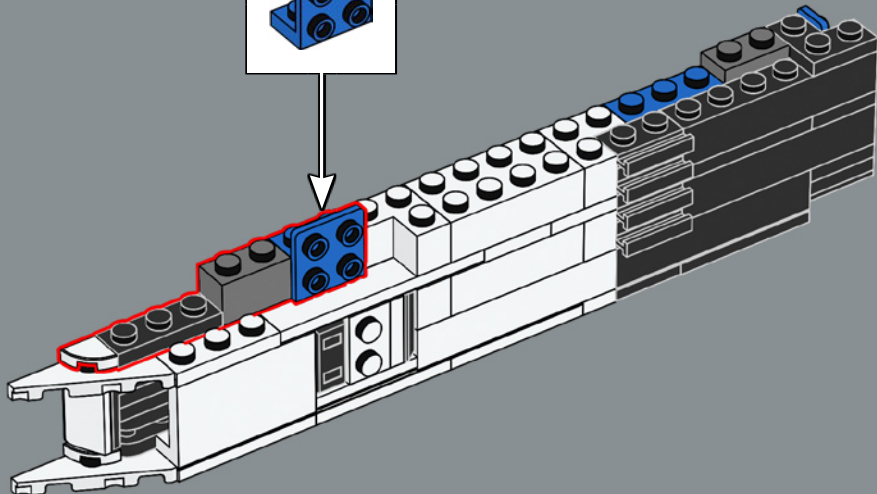
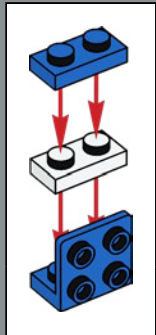

314

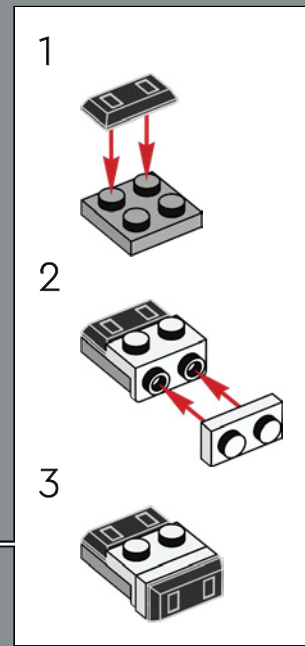
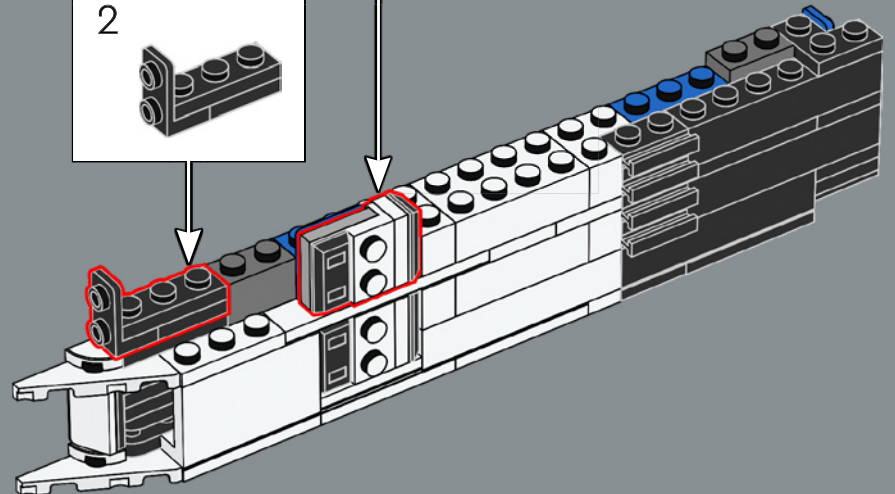
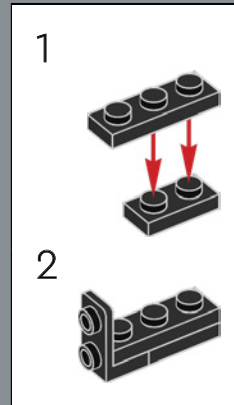

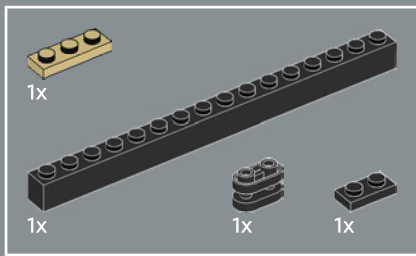

315

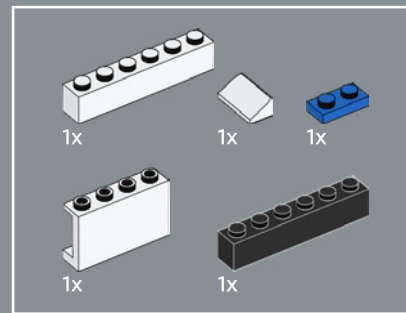
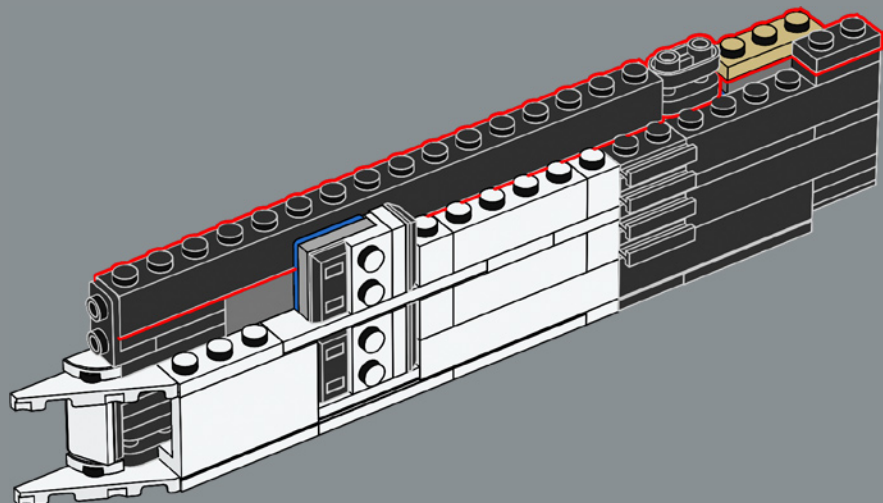

316

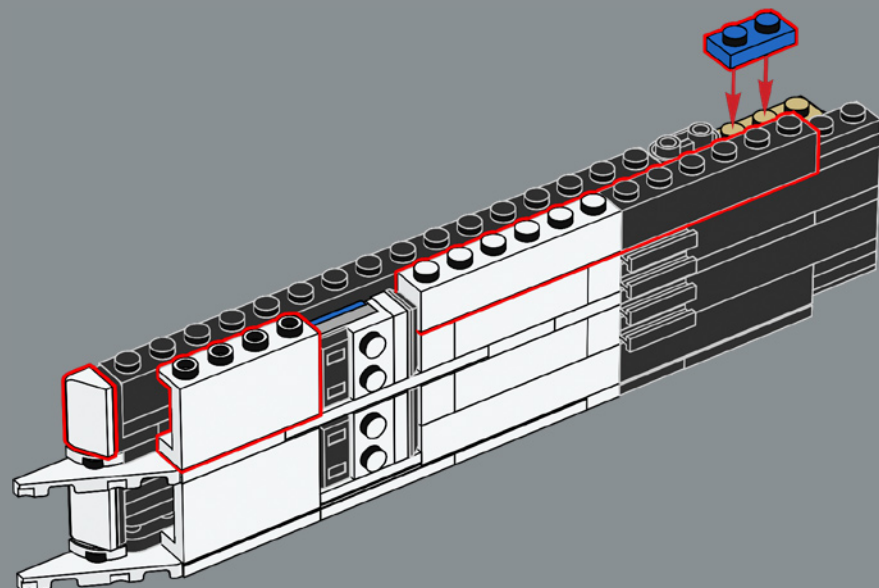

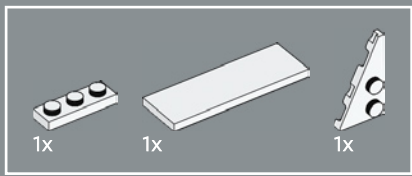

317

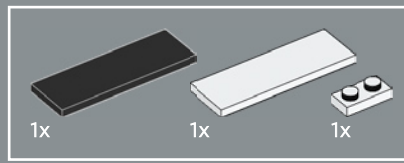
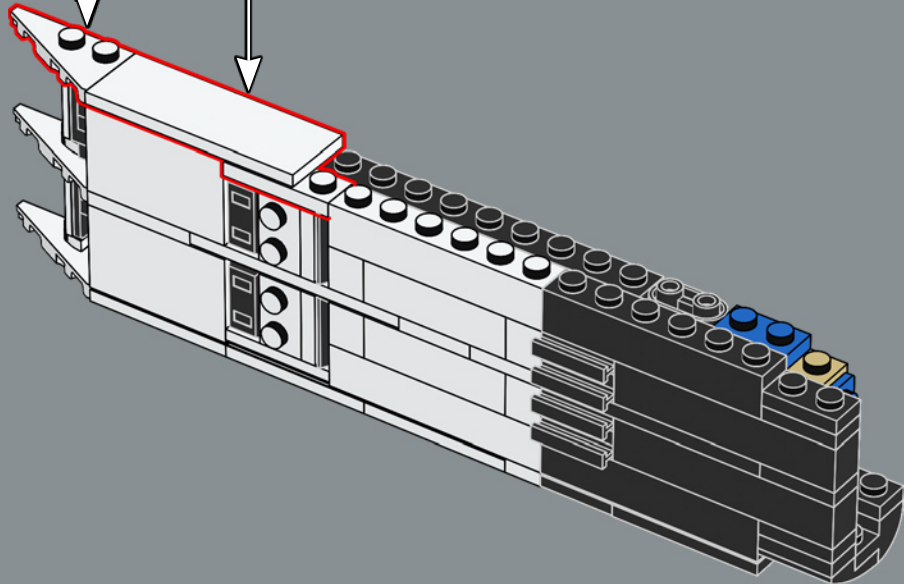
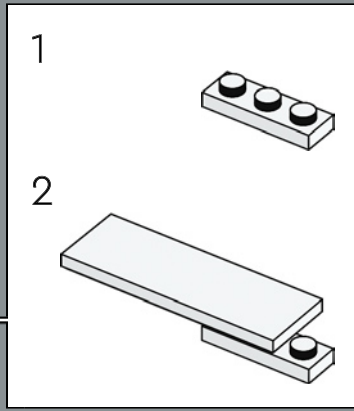
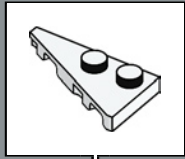

318

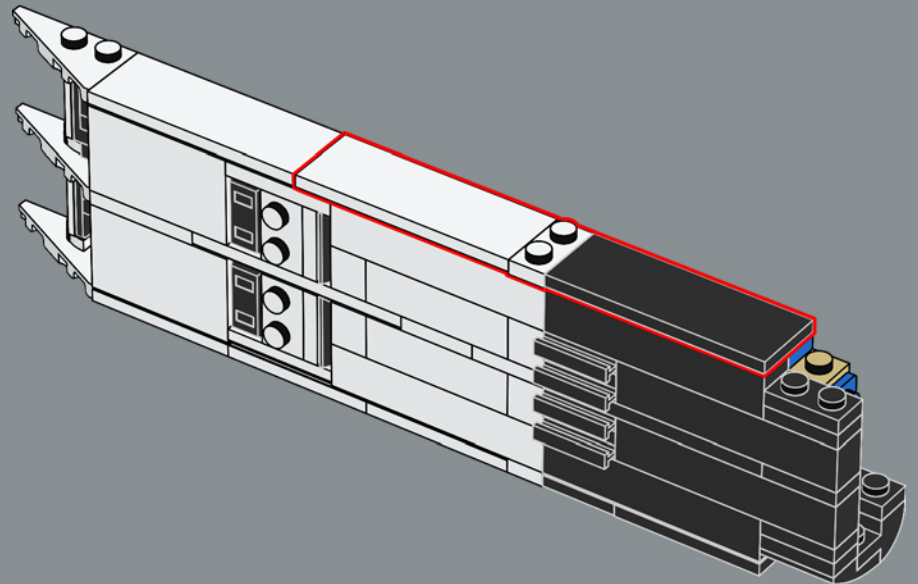



319

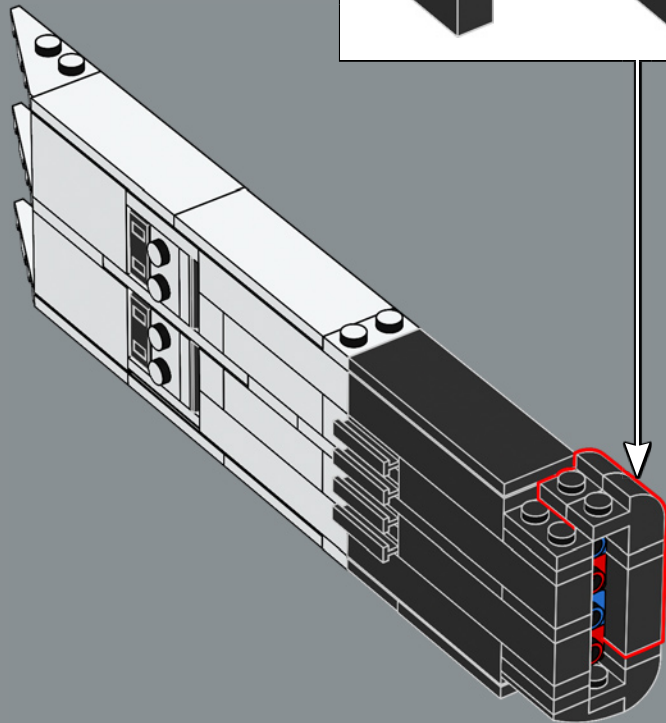
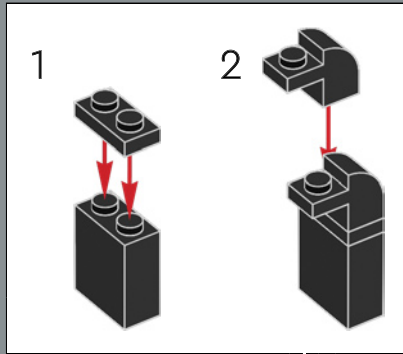

320

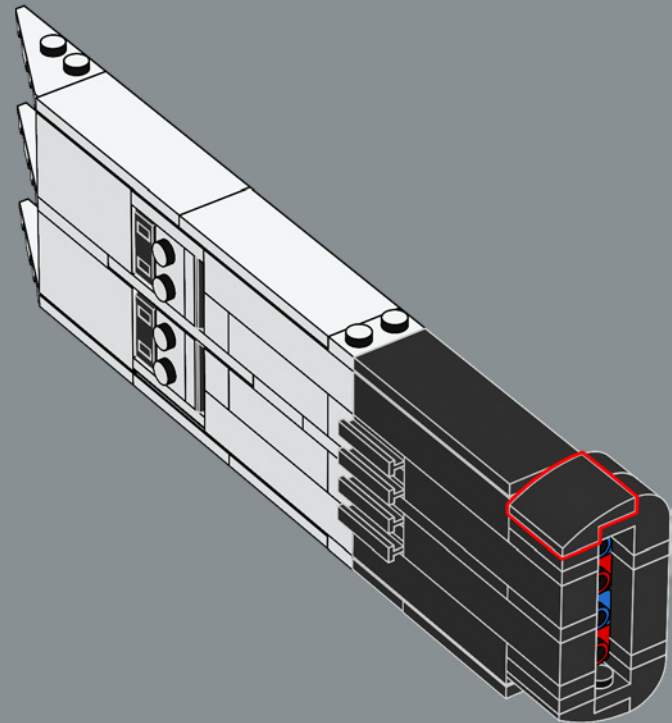



321

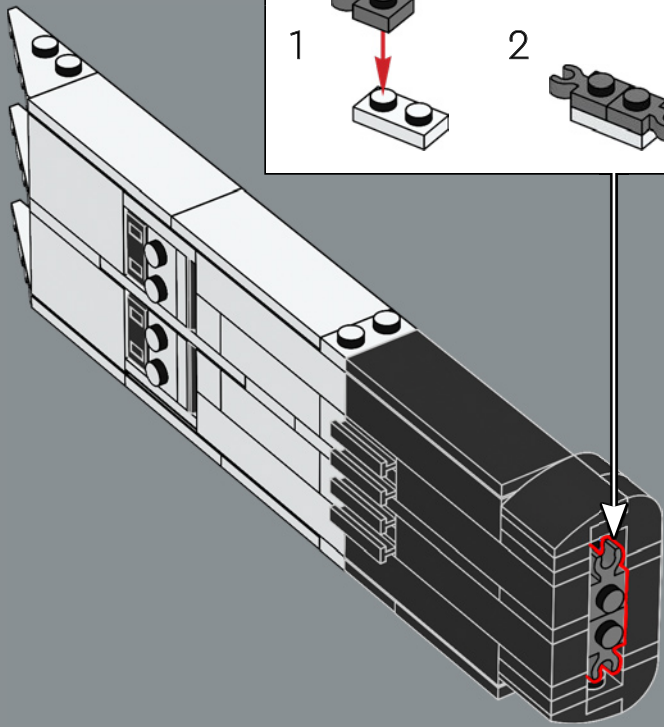
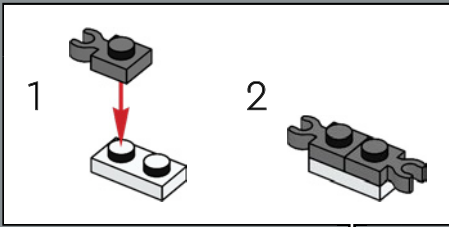

322

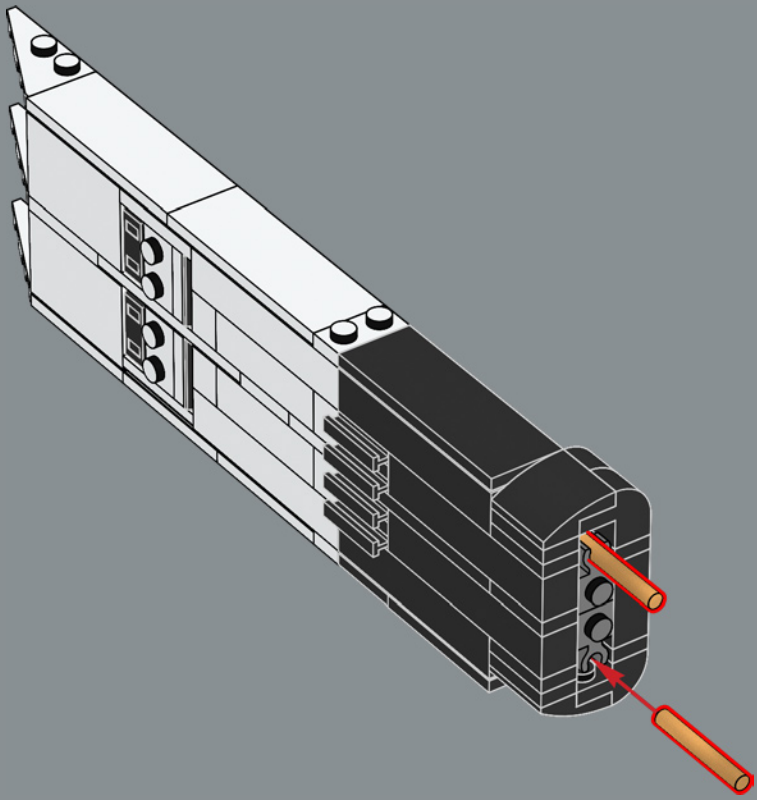

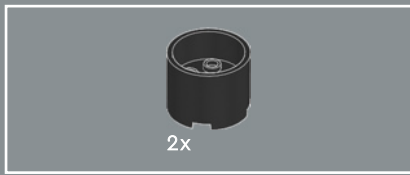

323

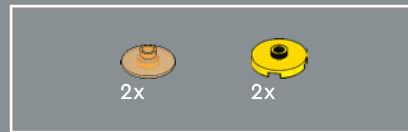
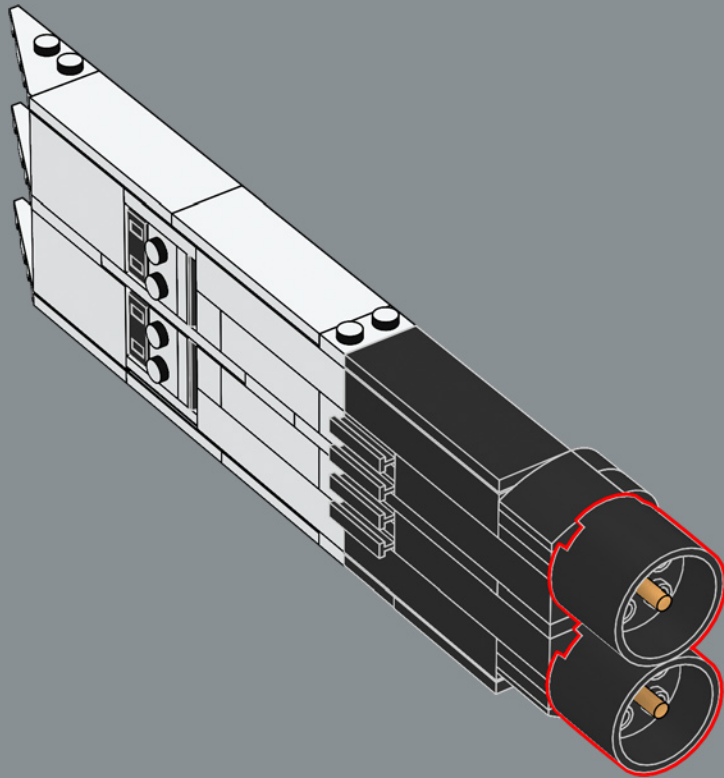

324

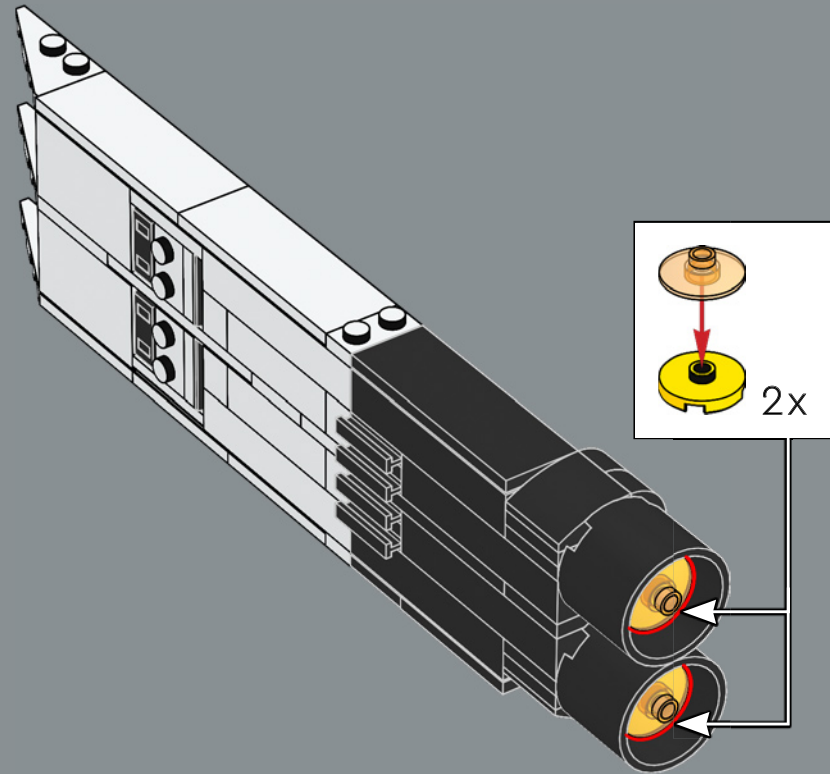



协和式飞机的四台著名的 Olympus 发动机将飞机的速度提升到音速的两倍。

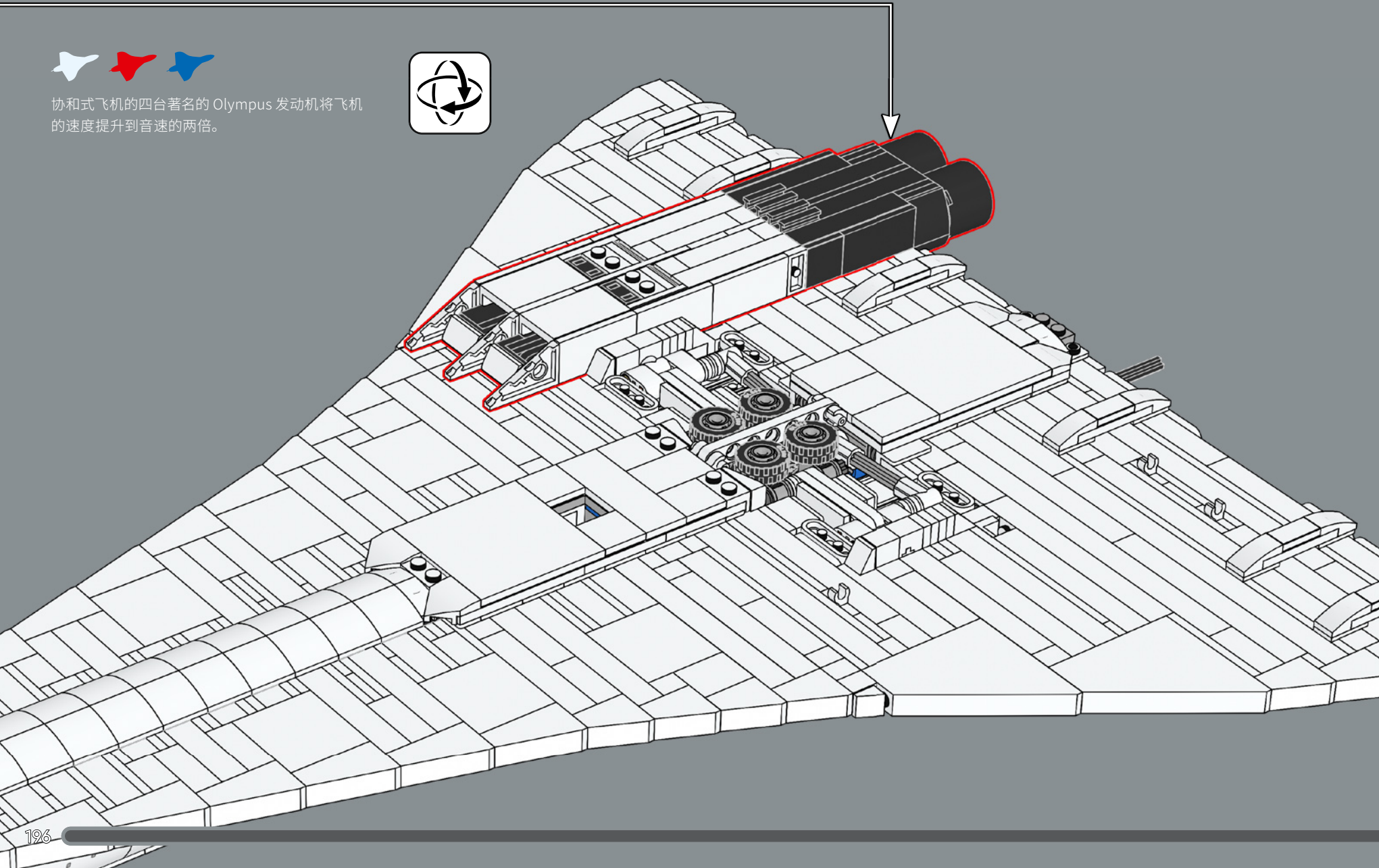

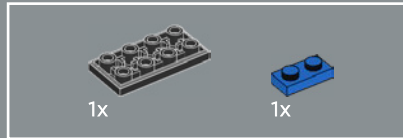
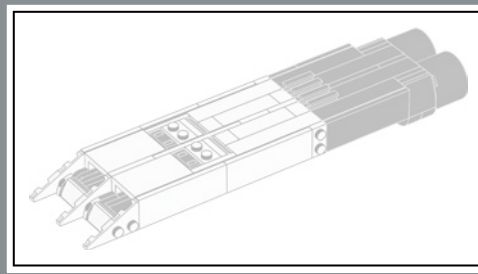

326

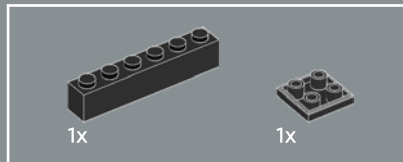
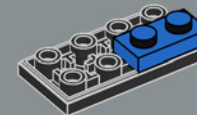

327

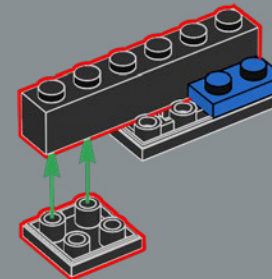

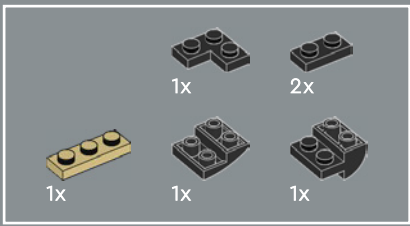

328

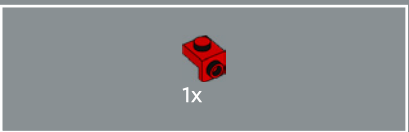
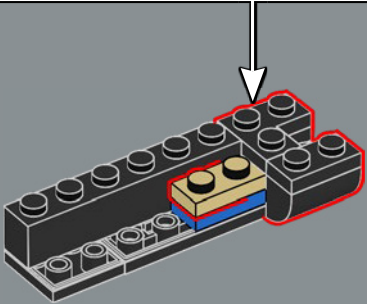
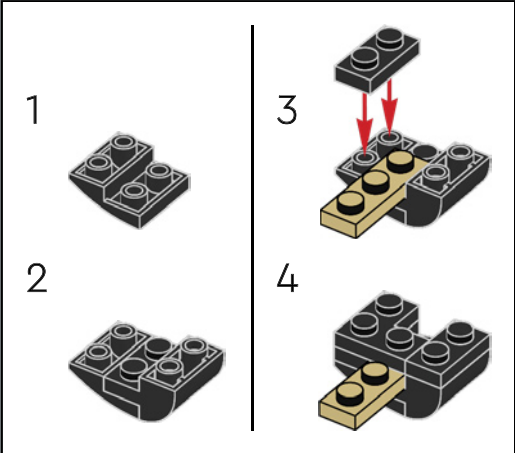

329

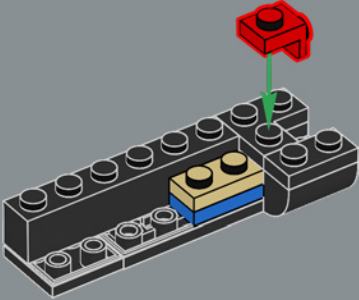

330

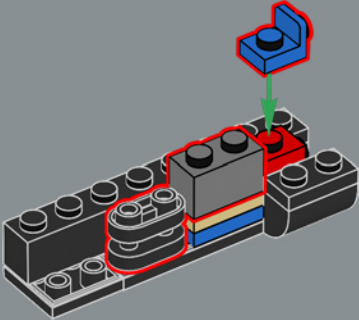

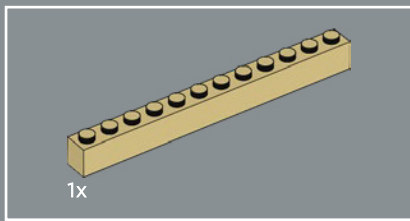

331

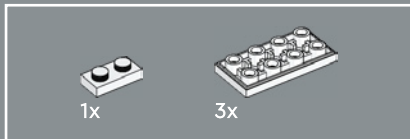
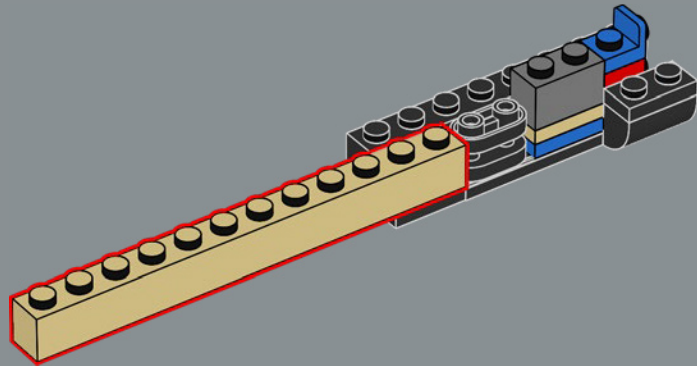

332

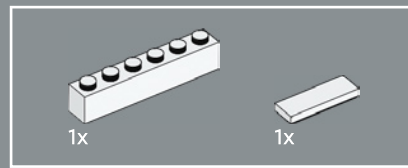
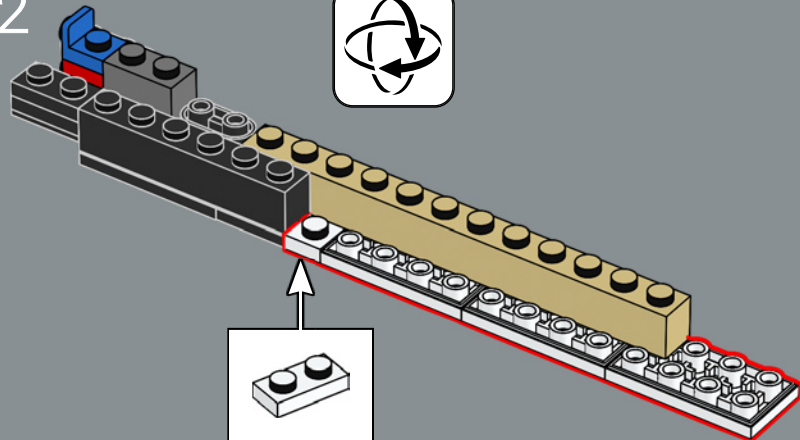

333

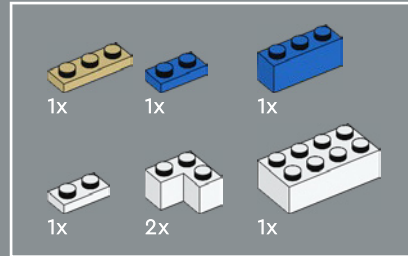
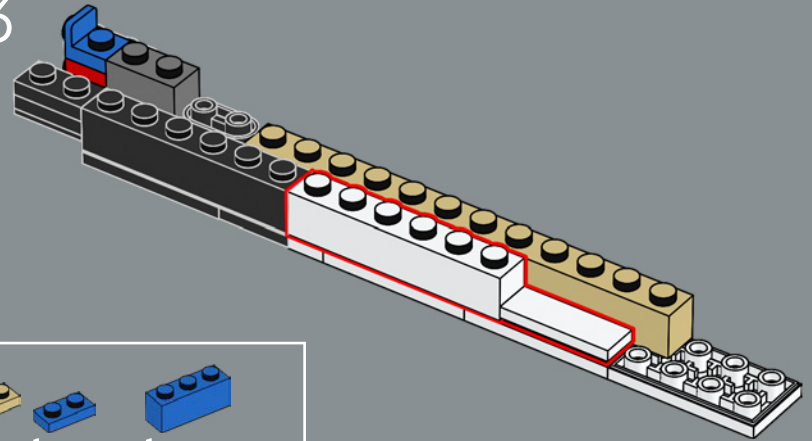

334

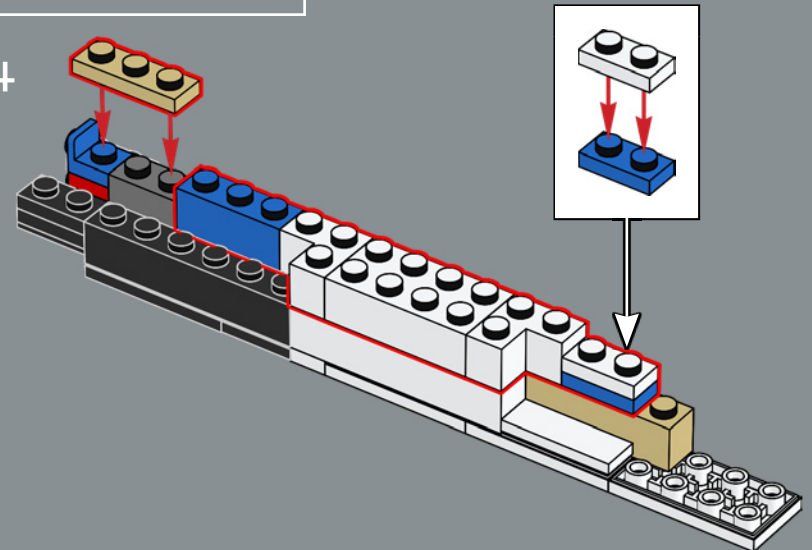

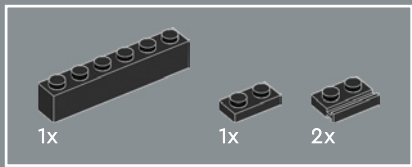

335

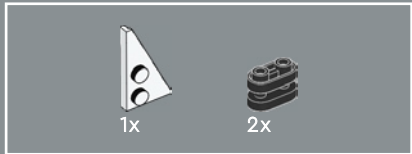
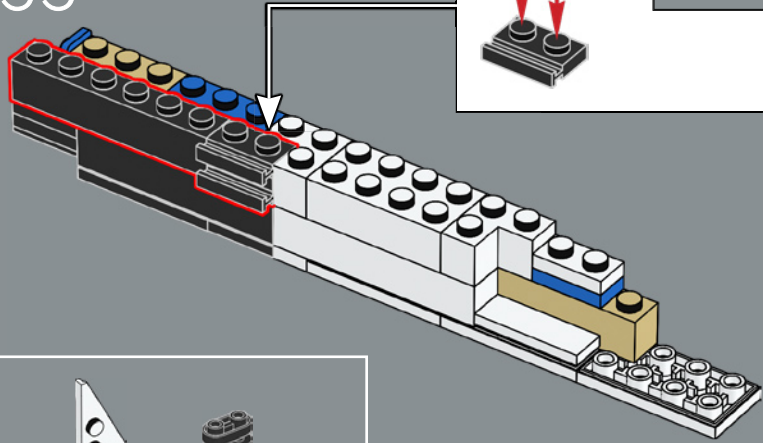
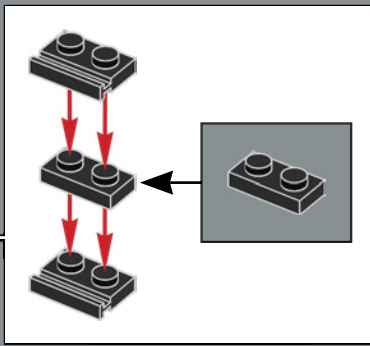

336

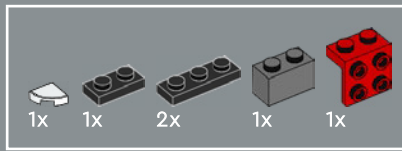
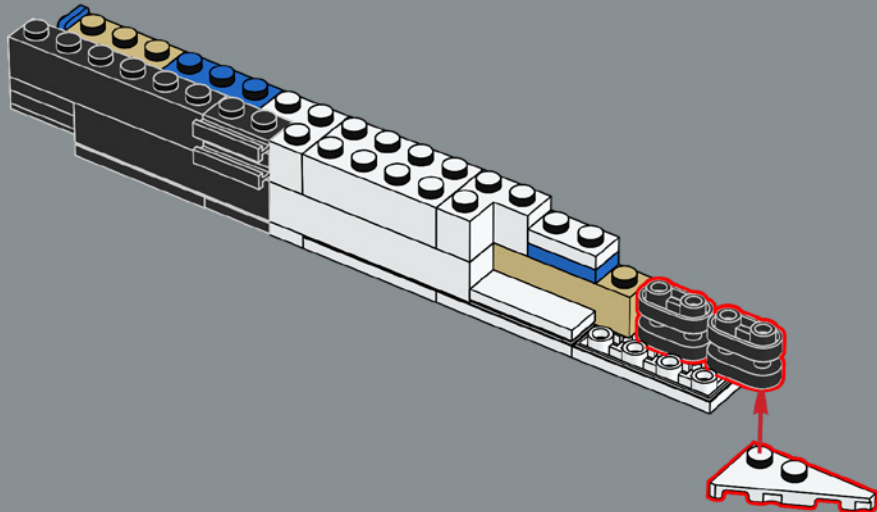

337

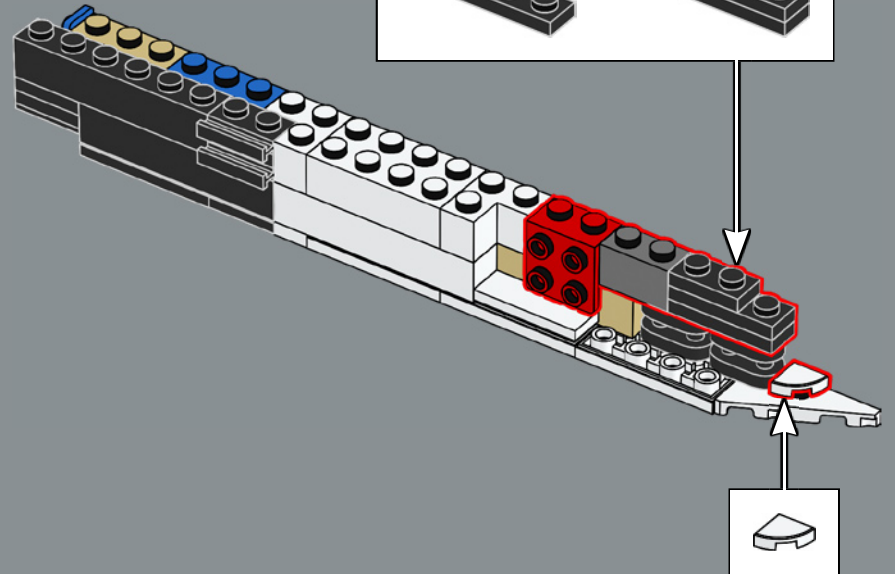
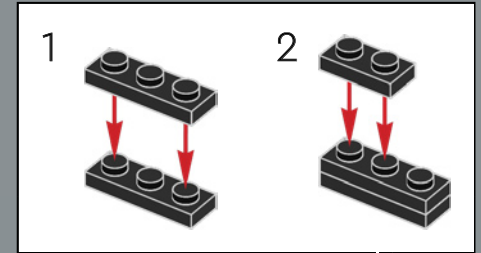

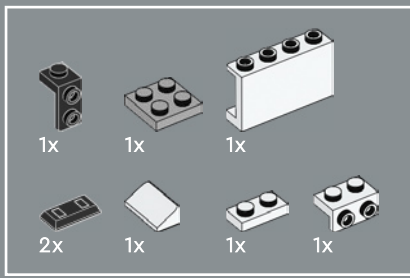

338

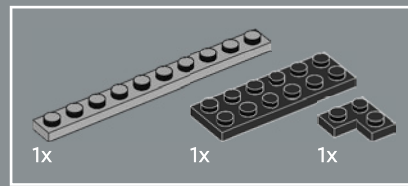
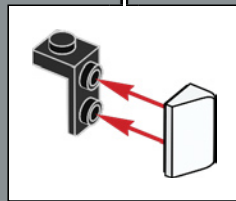
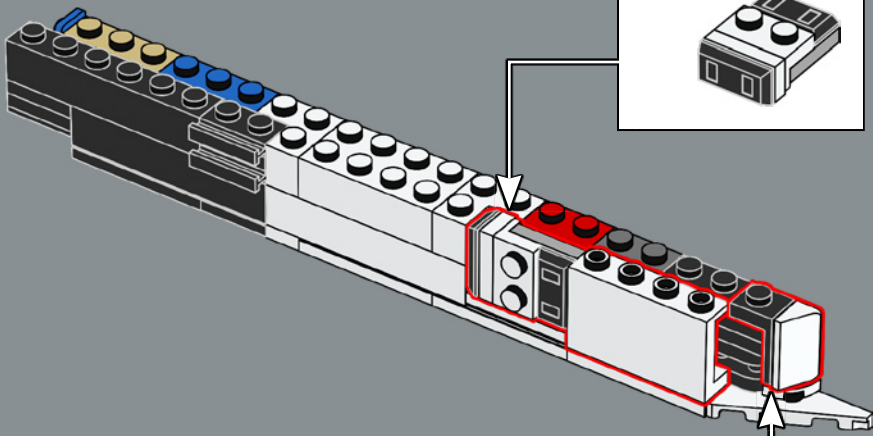
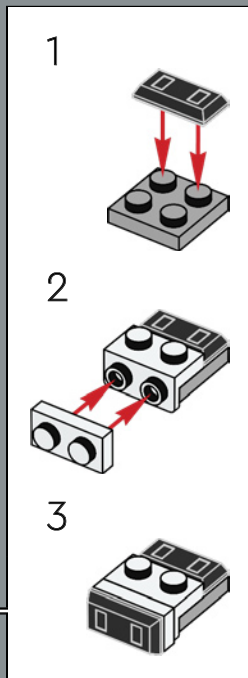

339

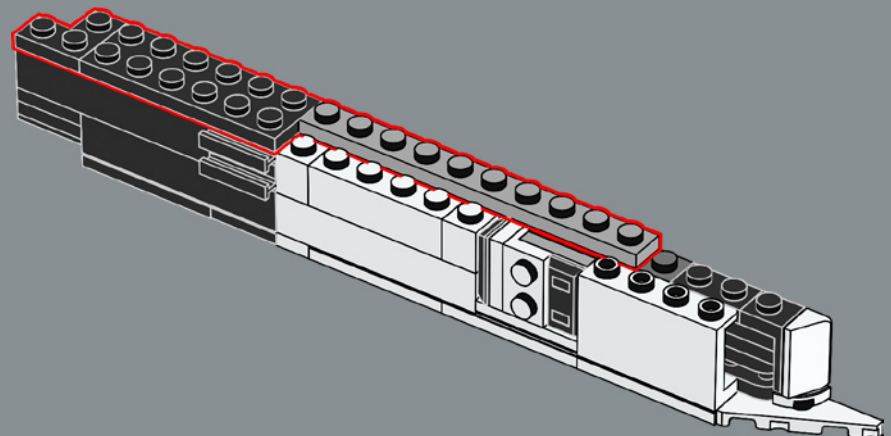

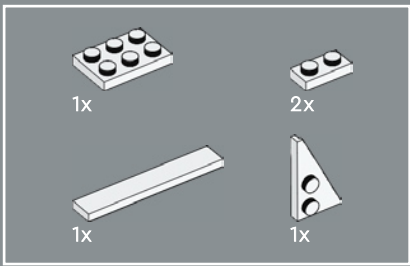

340

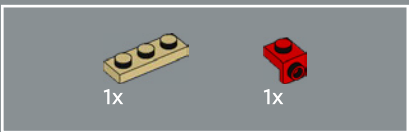
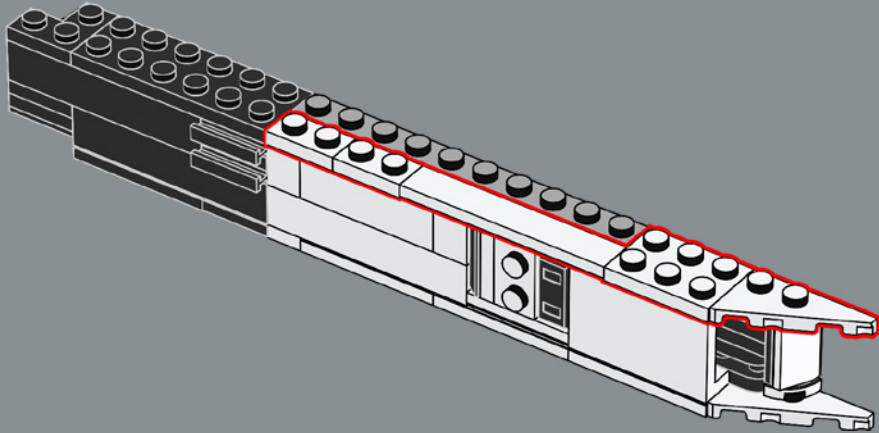

341

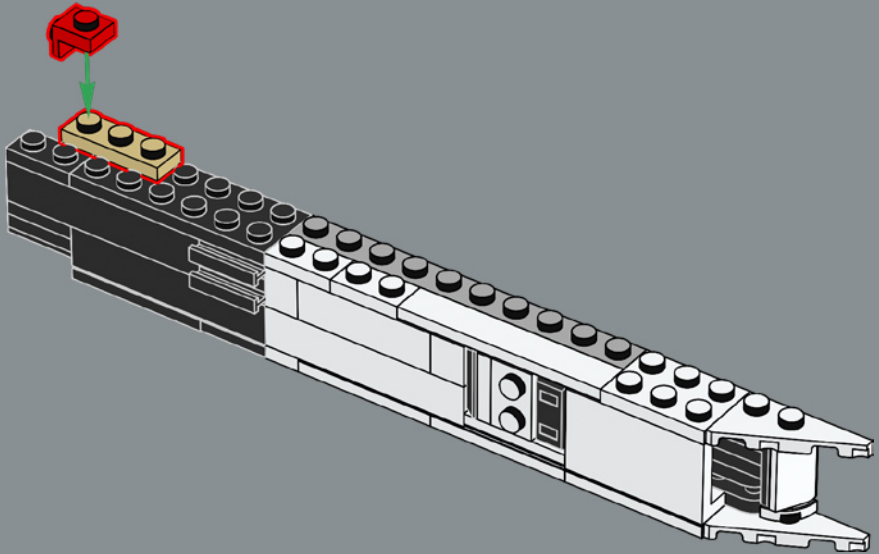

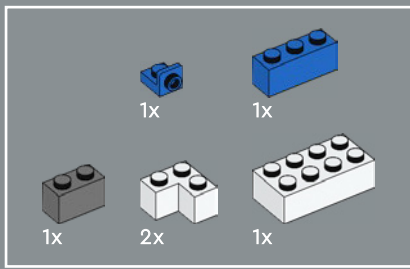

342

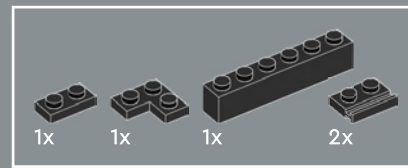
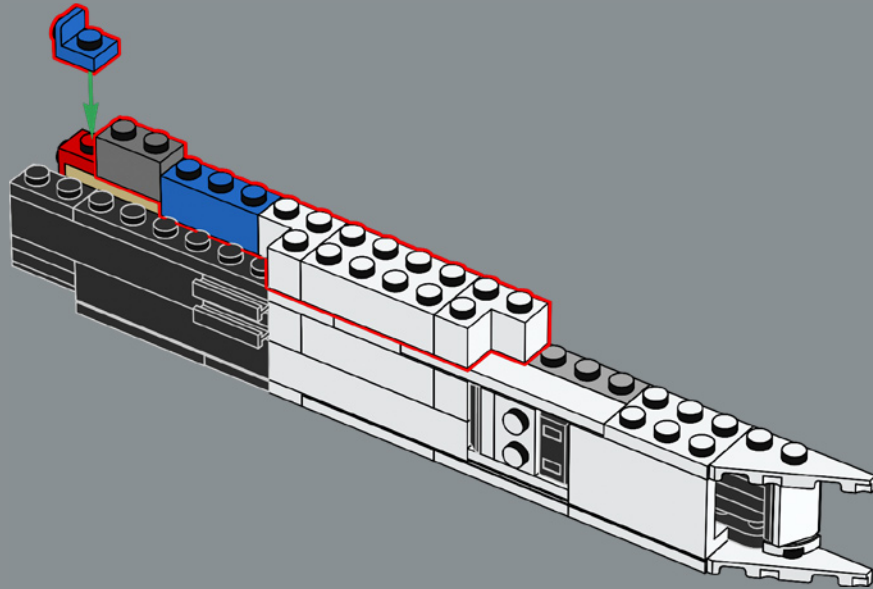

343

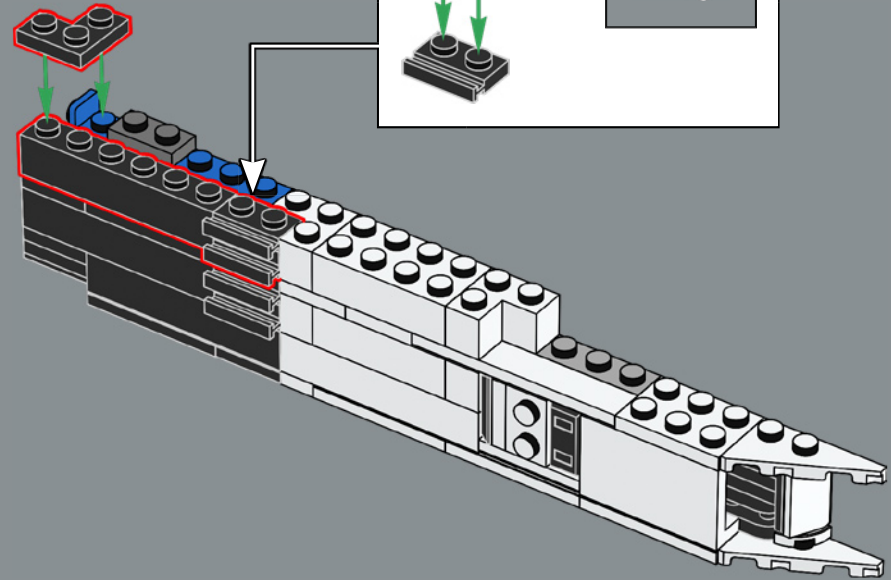
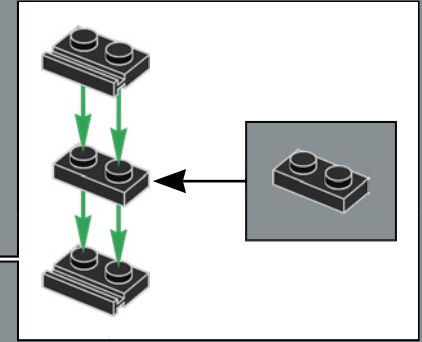

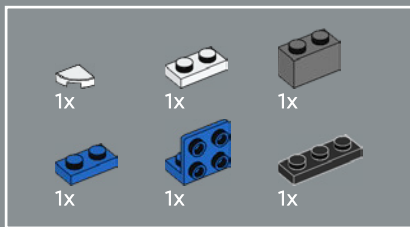

344

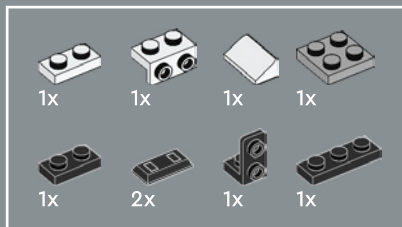
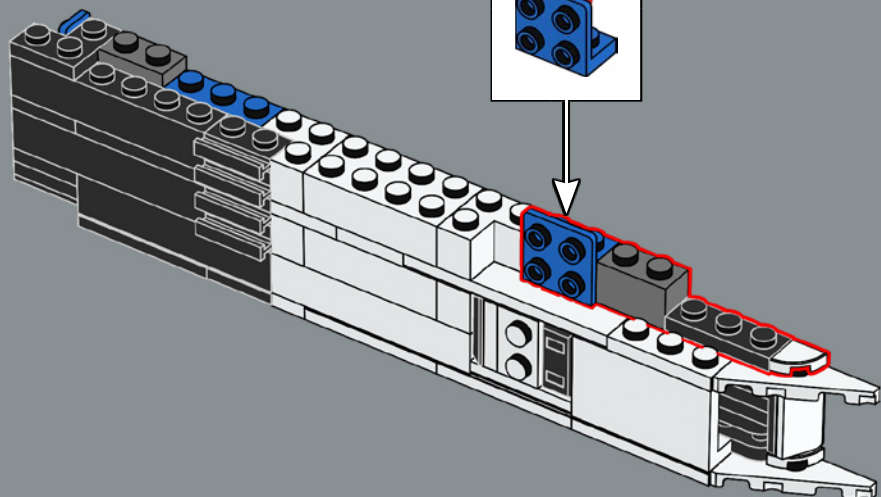
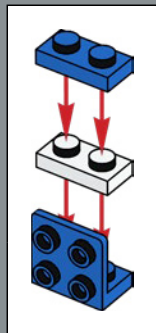

345

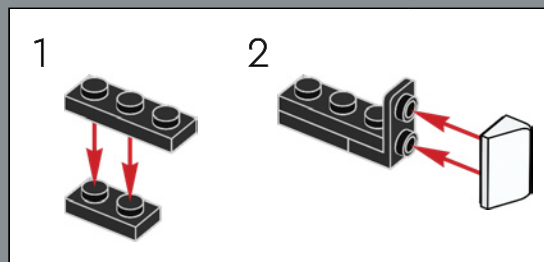
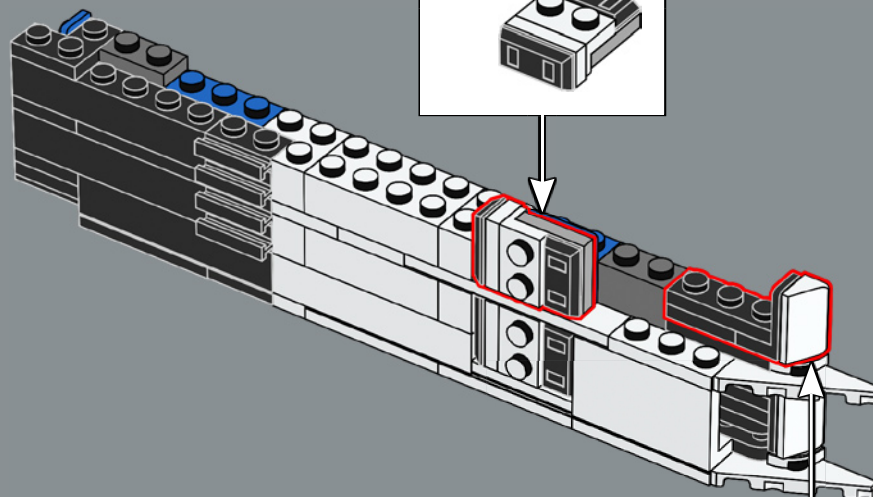
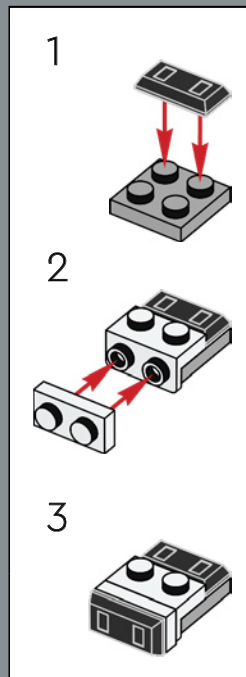

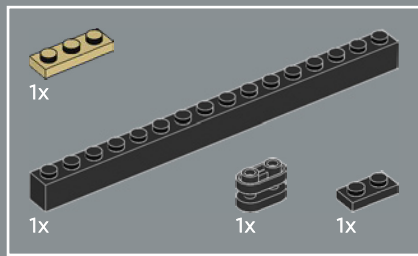

346

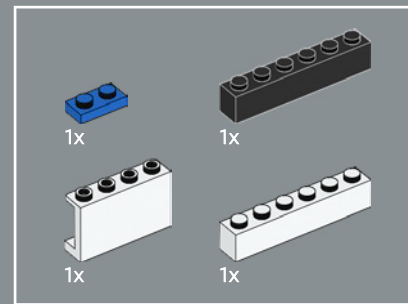
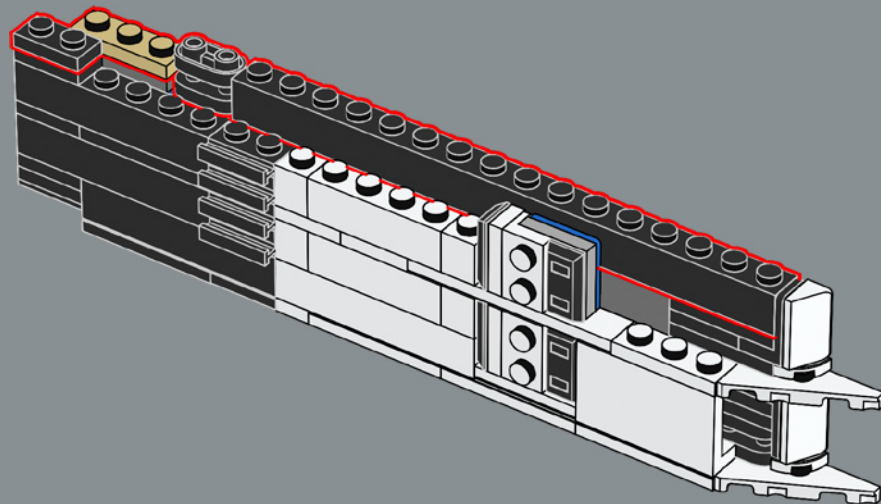

347

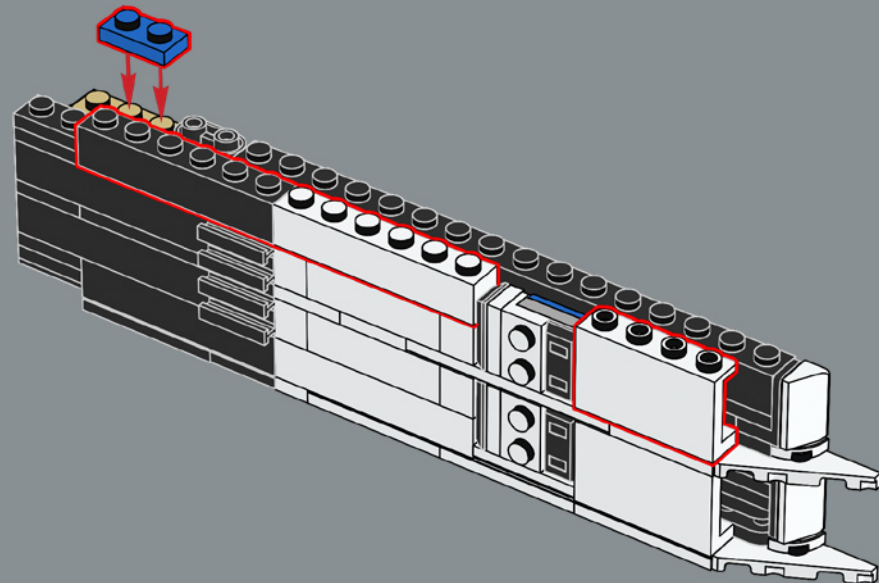

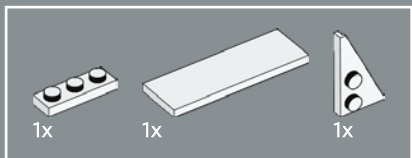

348

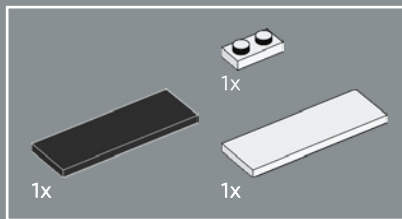
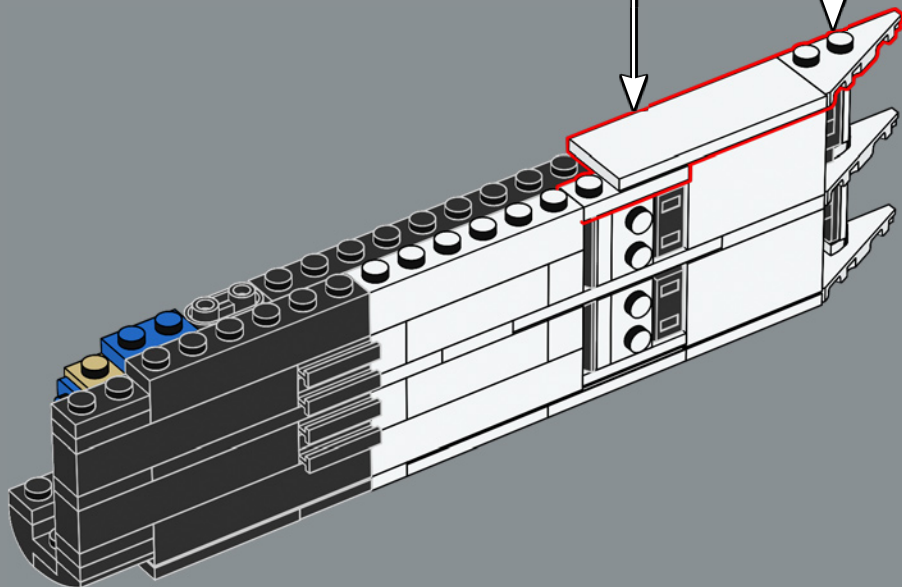
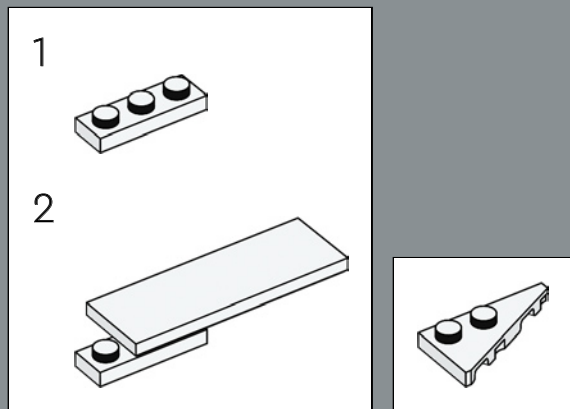

349

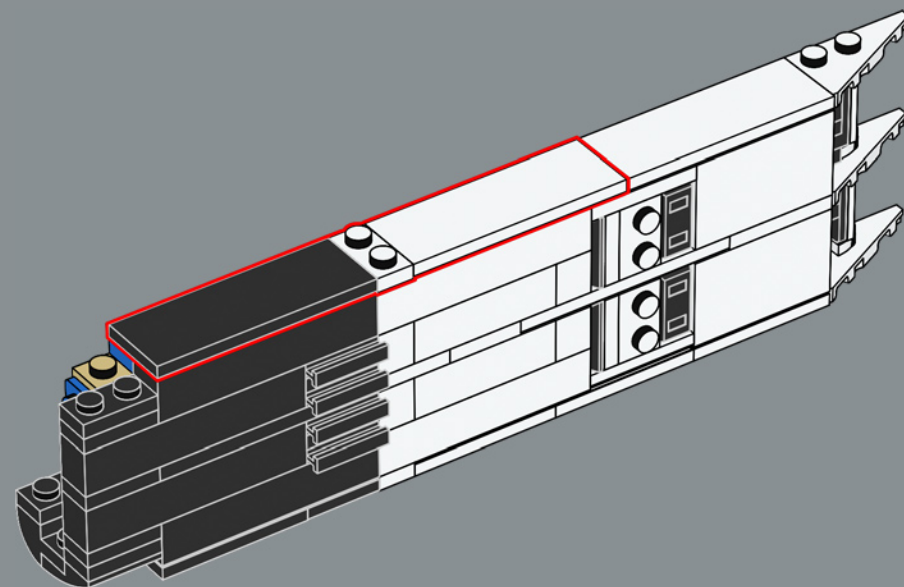



350

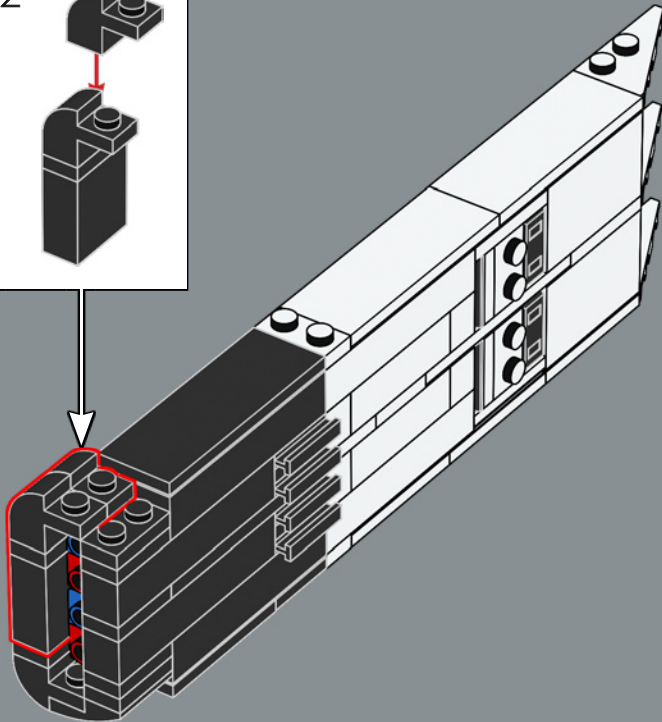
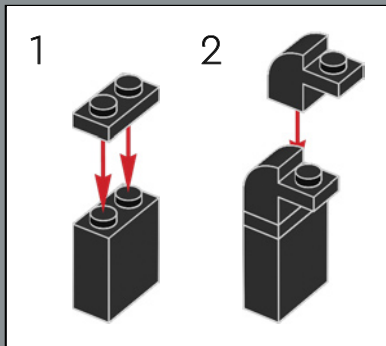

351

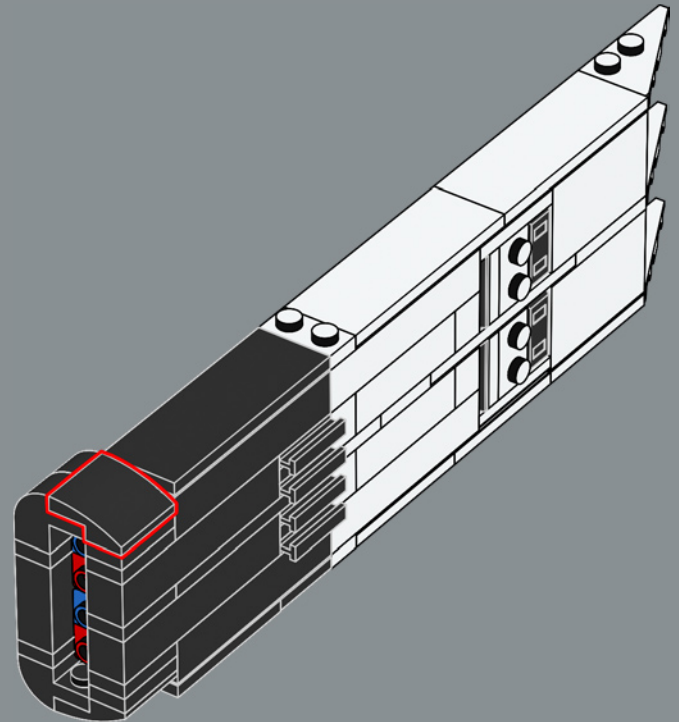



352

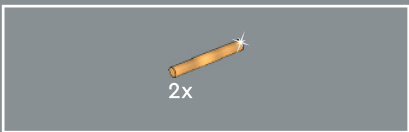
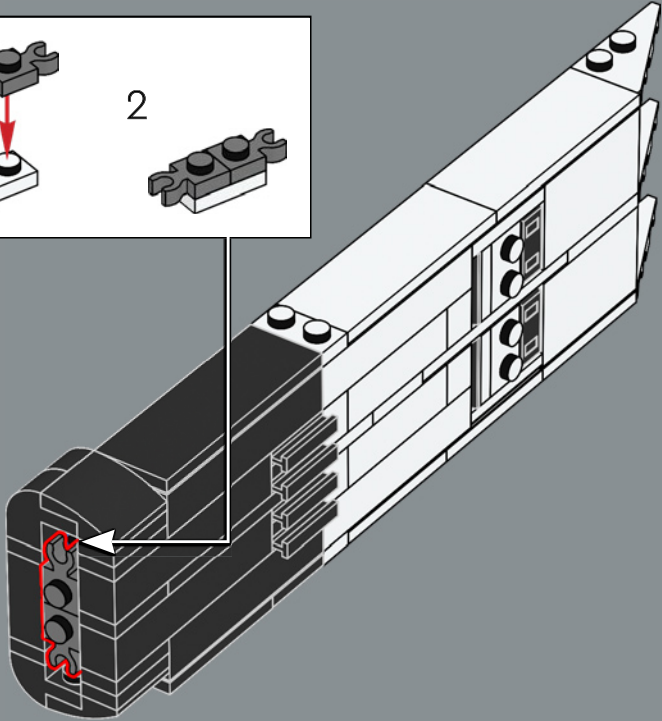
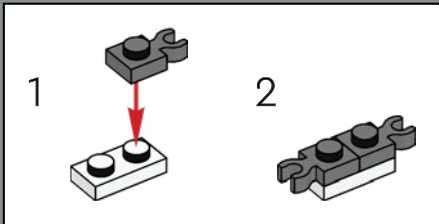

353

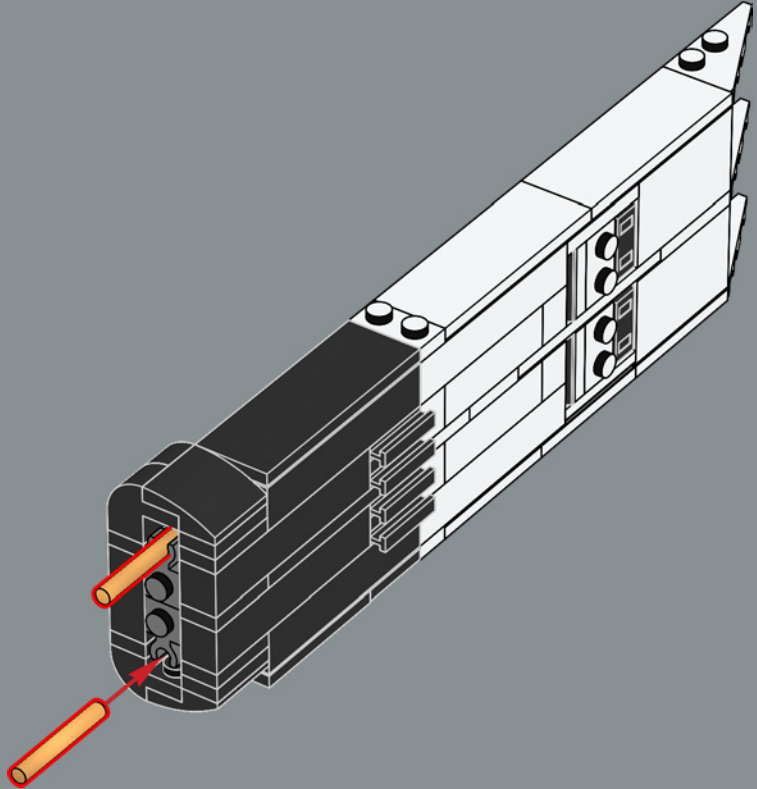

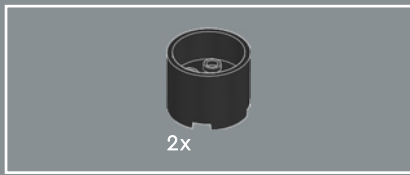

354

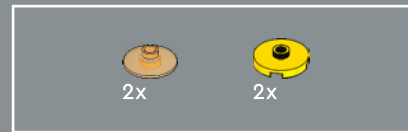
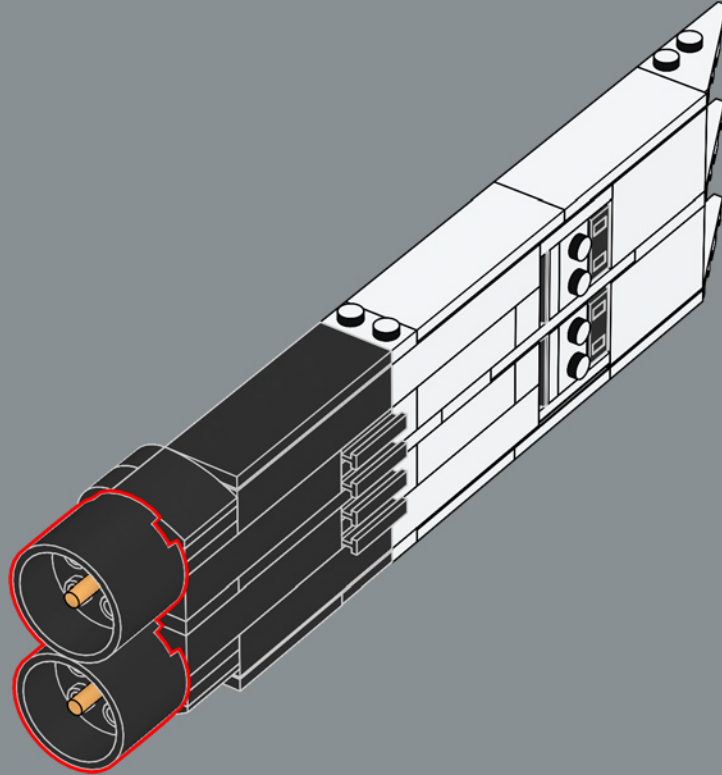

355

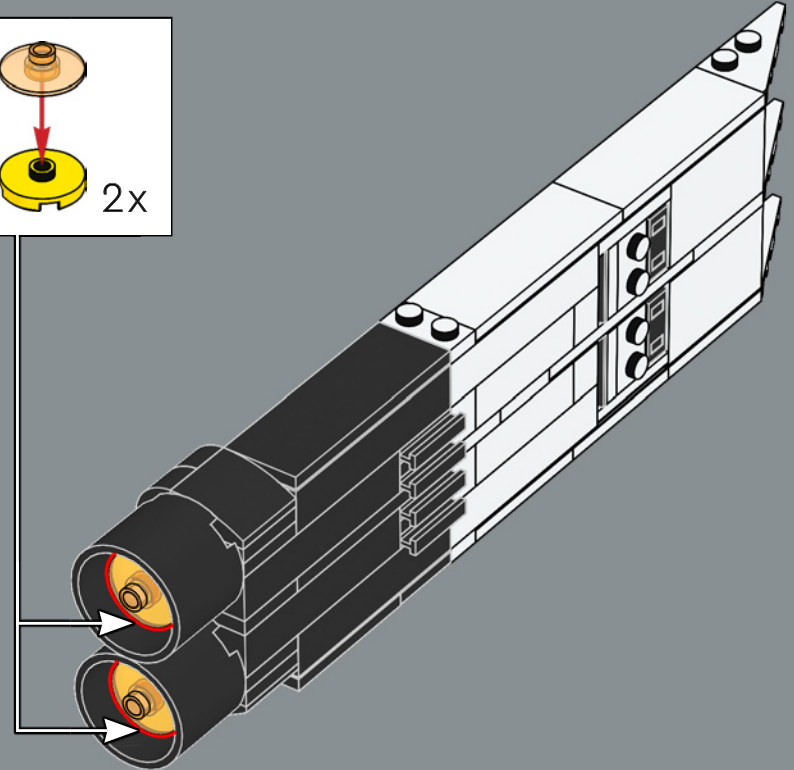
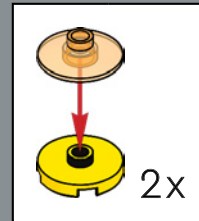



地球以 1673 公里/小时 (1040 英里/小时) 的速度旋转, 而协和式飞机以 2146 公里/小时 (1334 英里/小时) 的速度飞行, 那些乘坐飞机的人可以看到两次相同的日落。

356

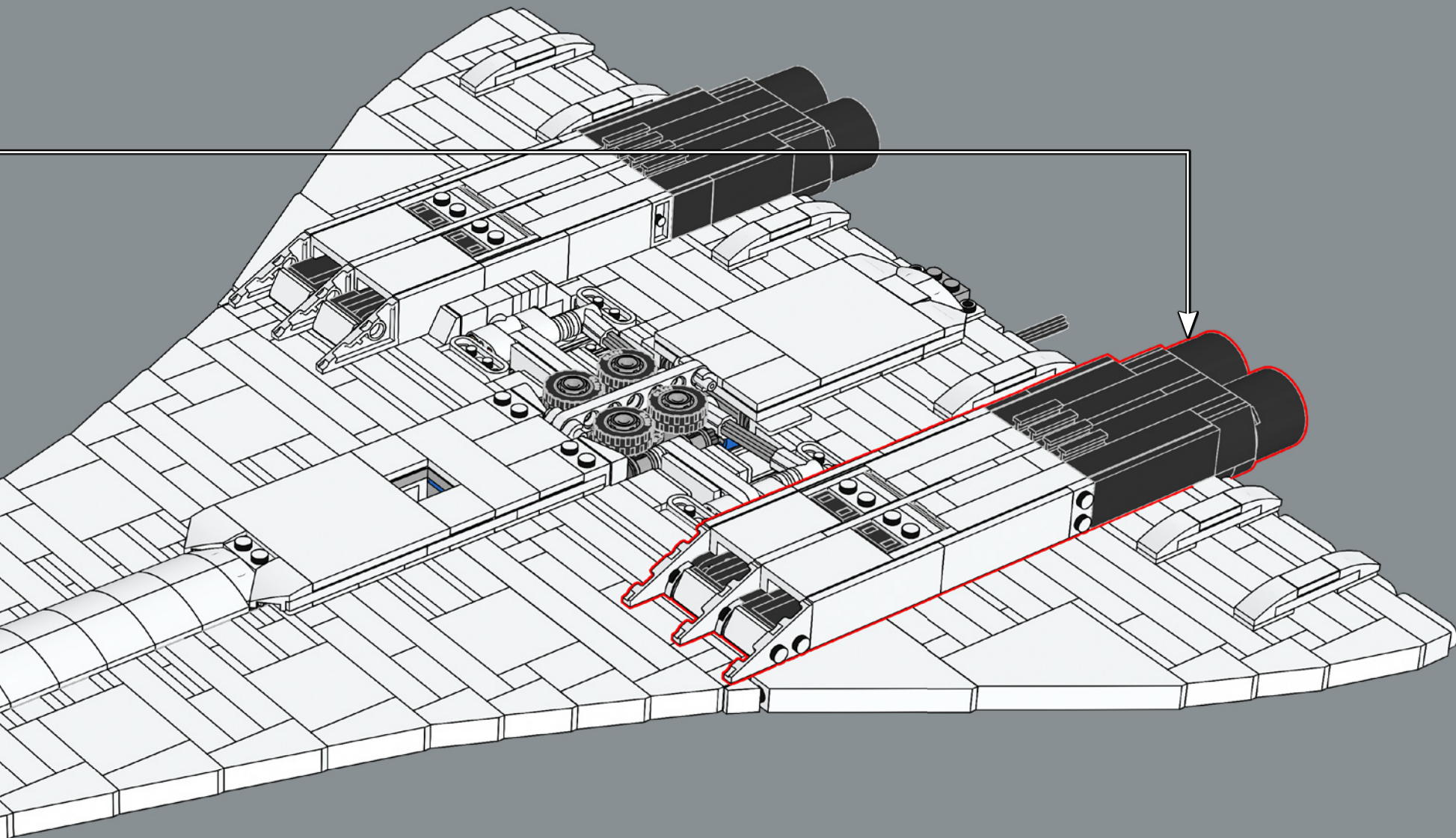

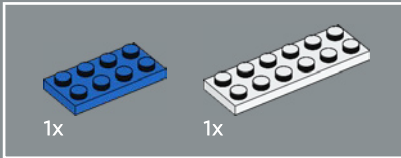
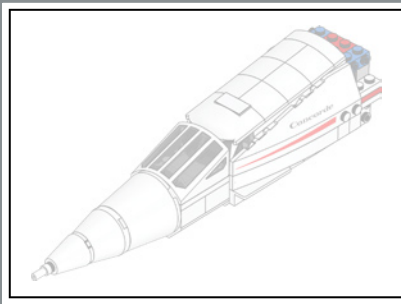

357

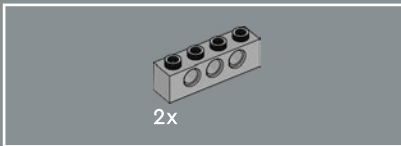
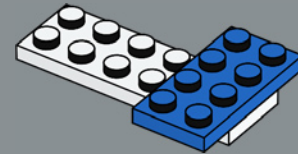

358

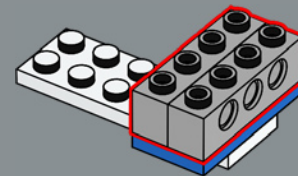

2x

359

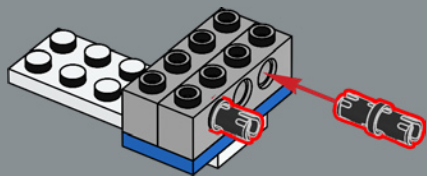

1x

361

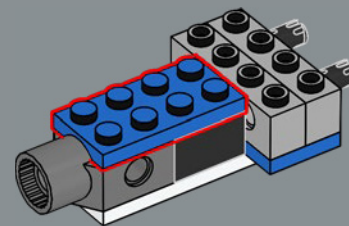

1x

1x

360

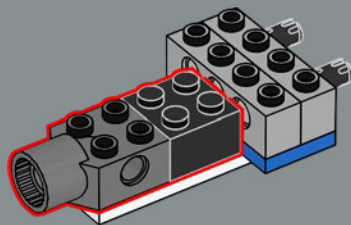

1x

1x

362

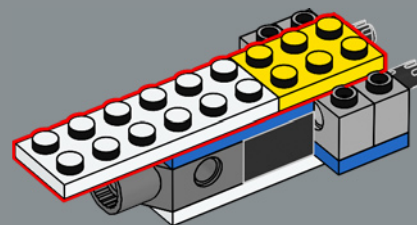



363

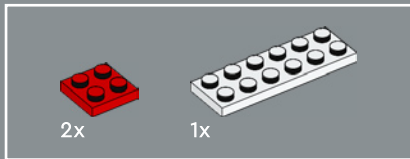
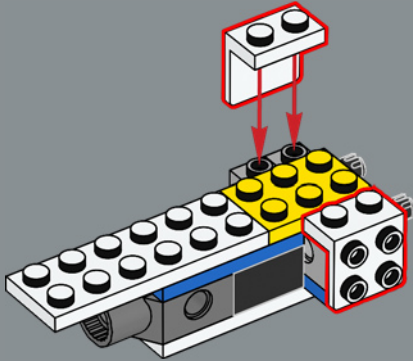

364

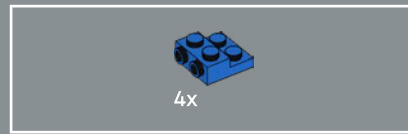
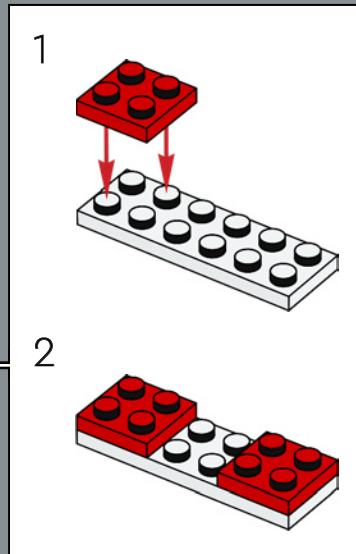
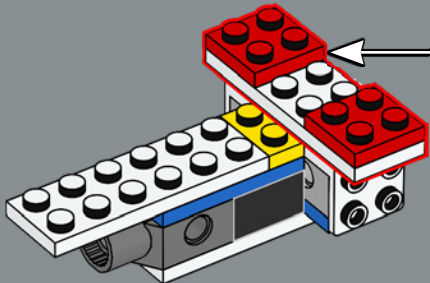

365

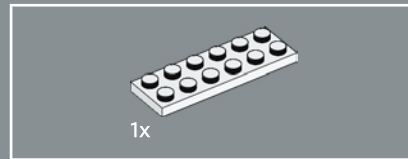
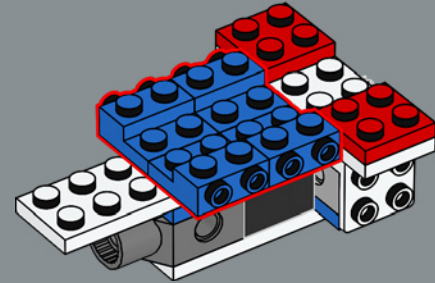

366

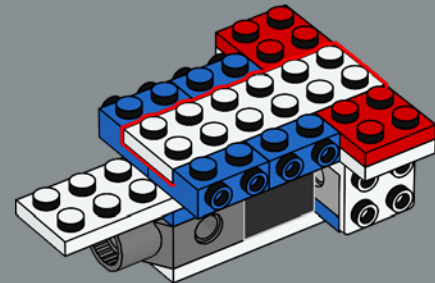



1x

367

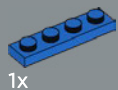

1x

368

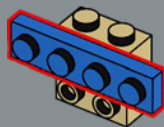

1x



1x

369

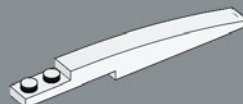
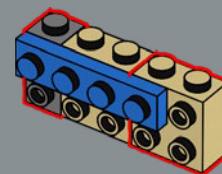

1x

370

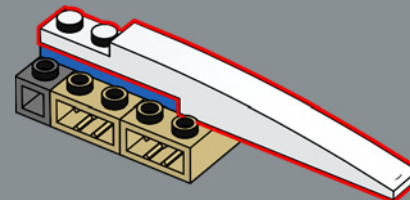

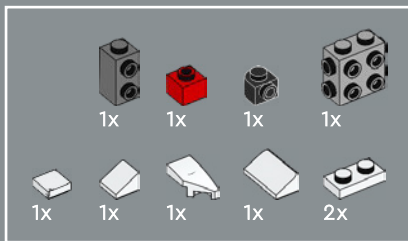

371

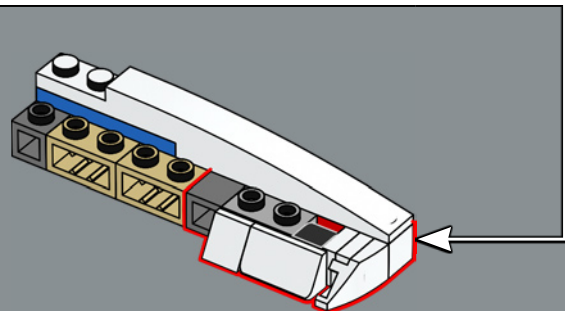
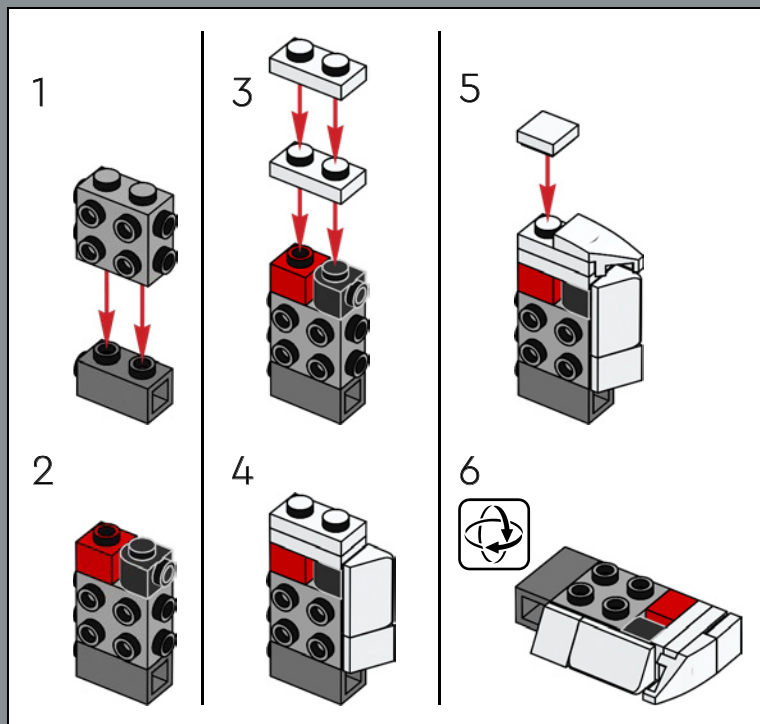

372

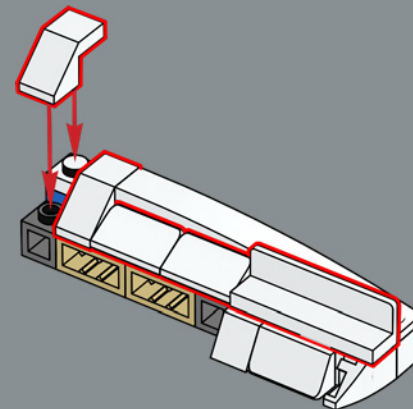

373

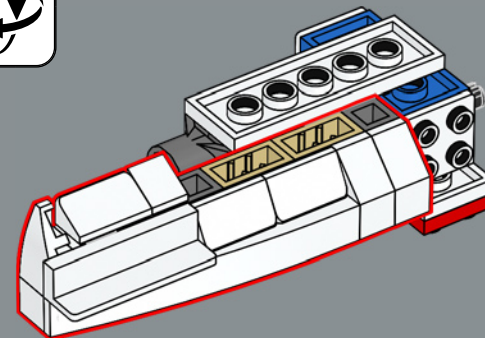



1x

374



1x

375

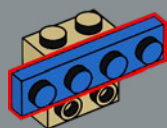

共有 134 名飞行员和 57 名飞行工程师接受了操作这款独特飞机的培训。



1x



1x

376

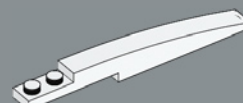
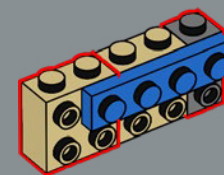

1x

377

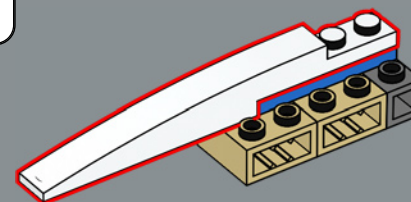

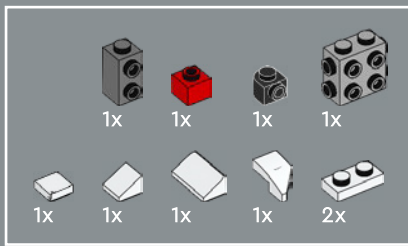

378

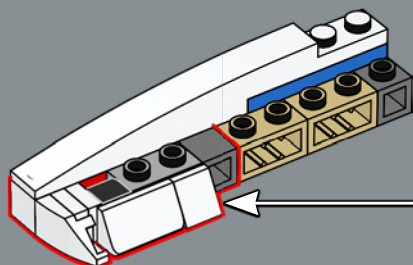
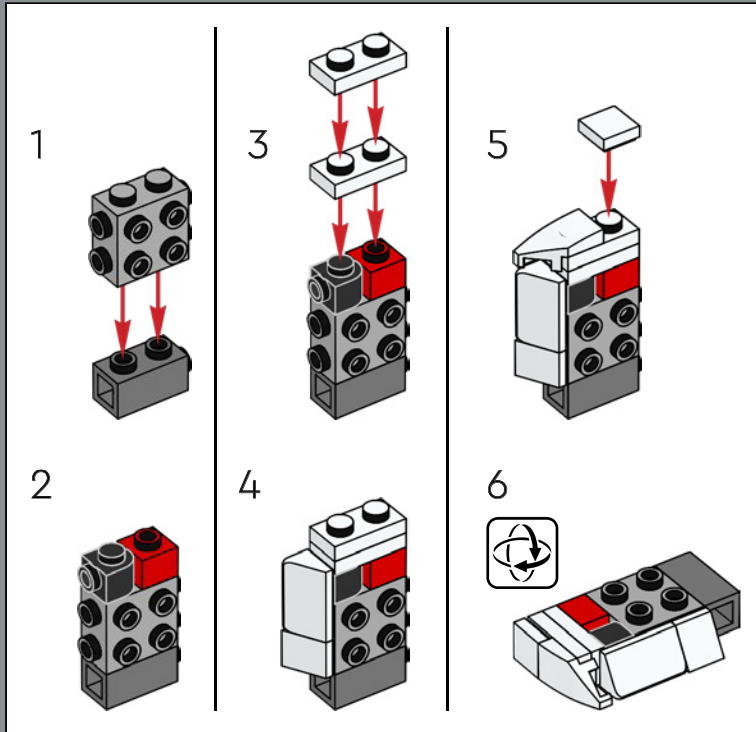

379

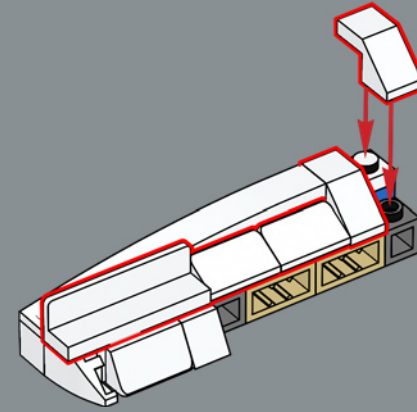

380

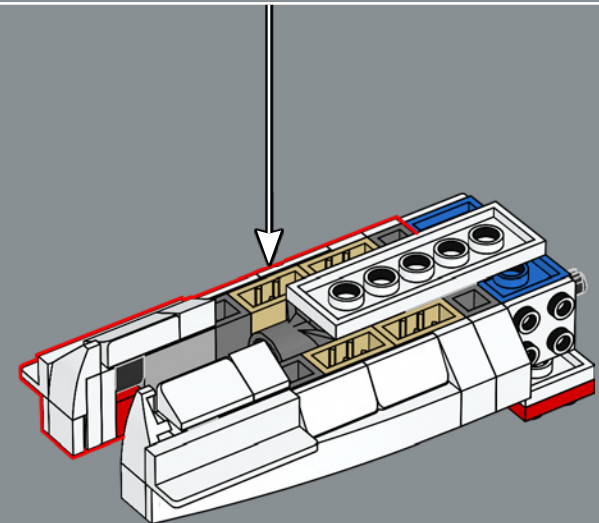

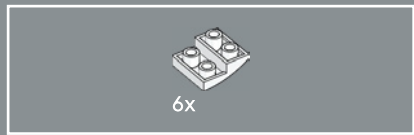

381

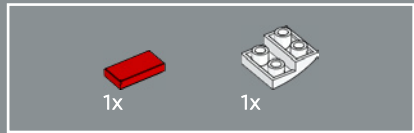
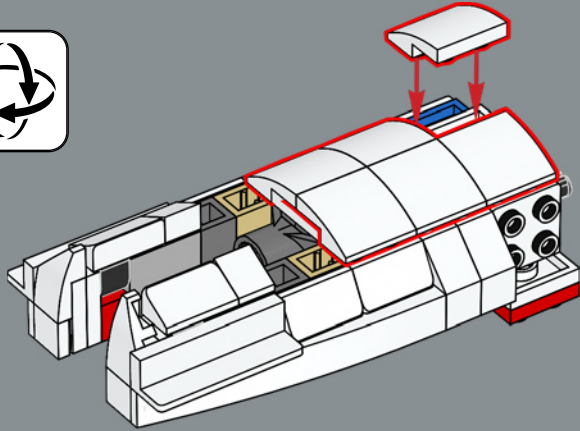

382

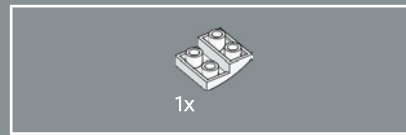
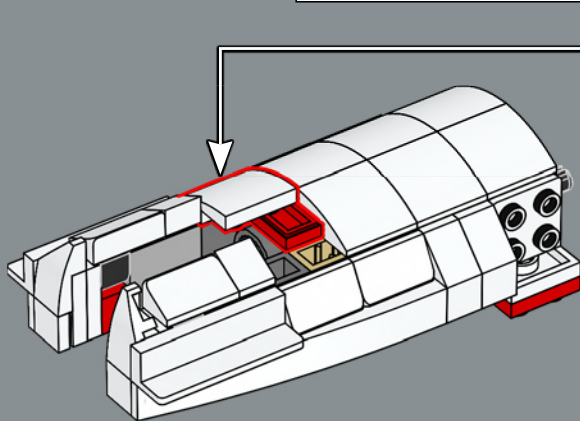
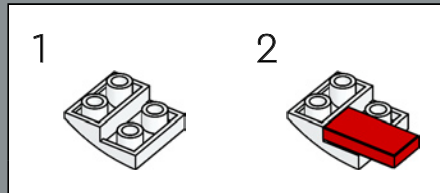

383

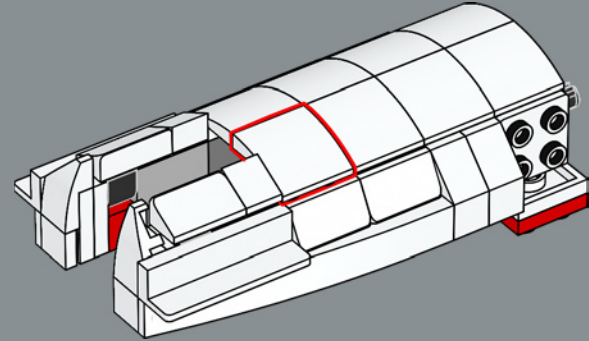

384

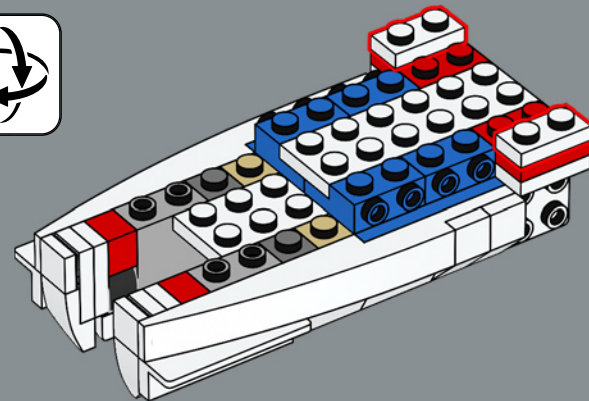

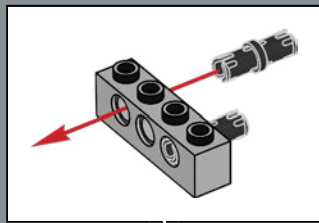
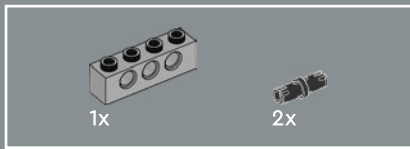

385

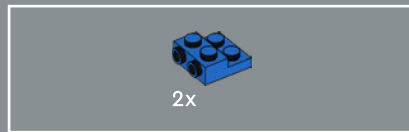
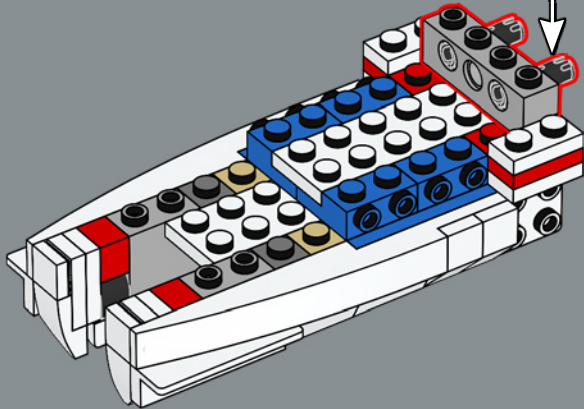

387

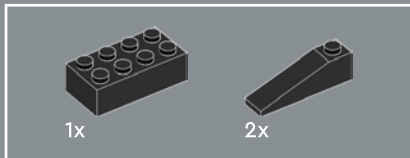
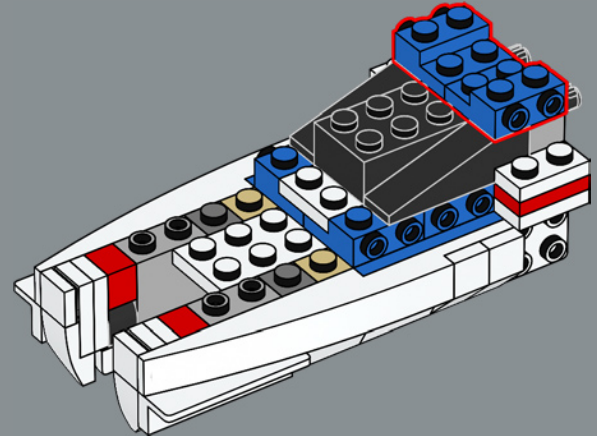

386

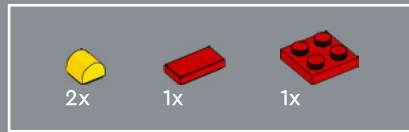
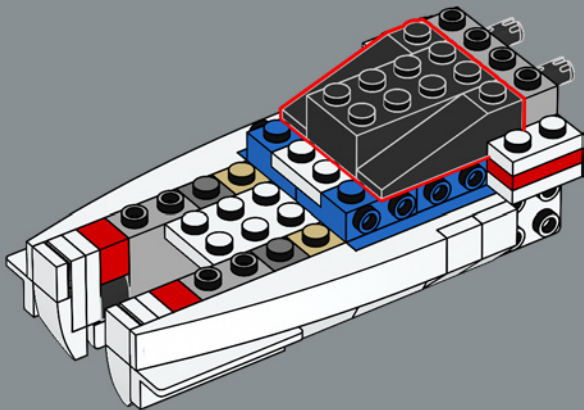

388

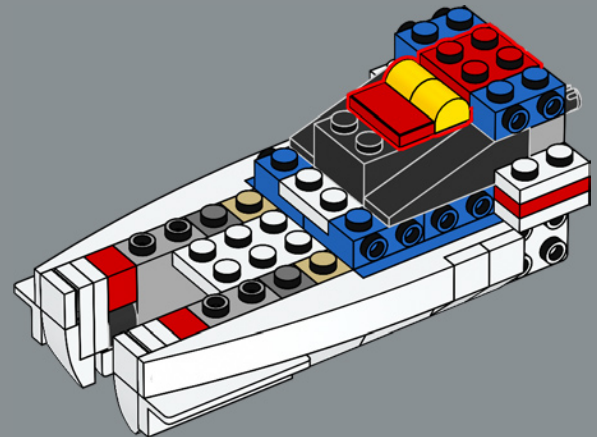

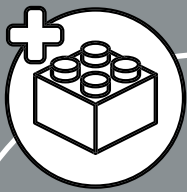

1x



17

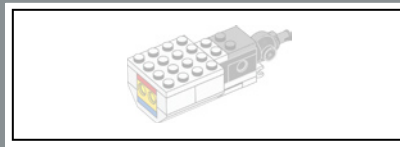

1x



1x

389

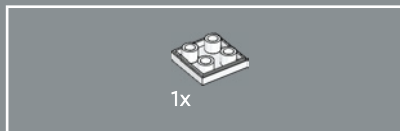
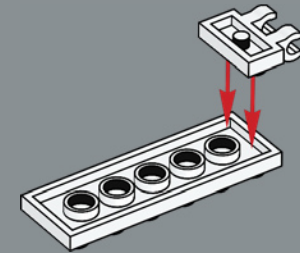

1x

390

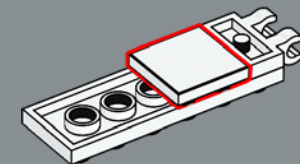

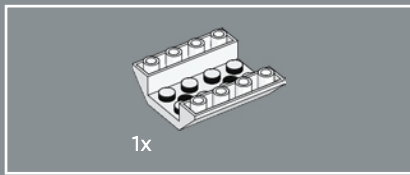

391

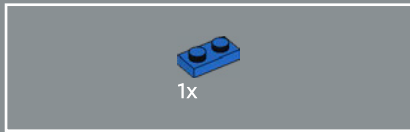
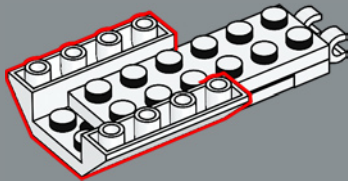

392

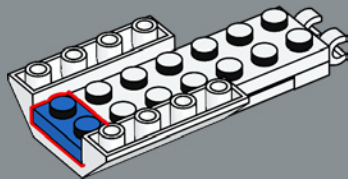

393

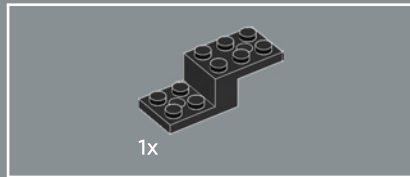
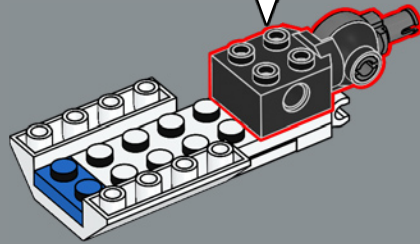
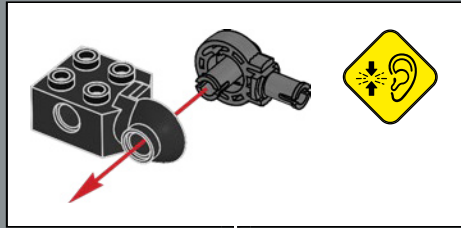

394

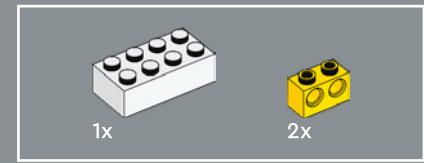
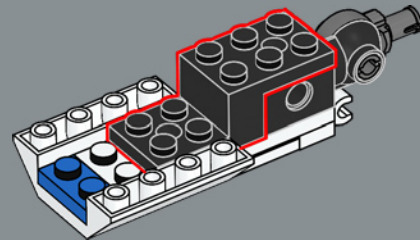

395

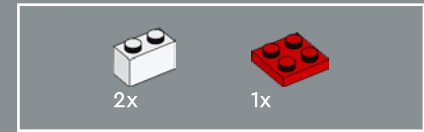
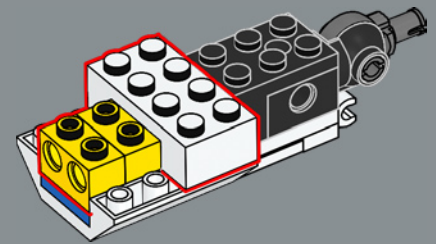

396

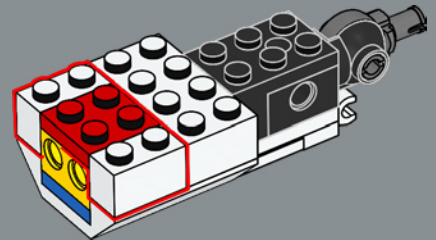

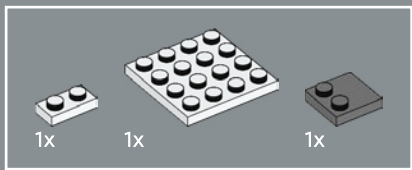

397

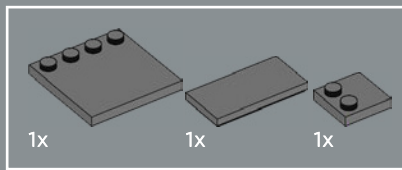
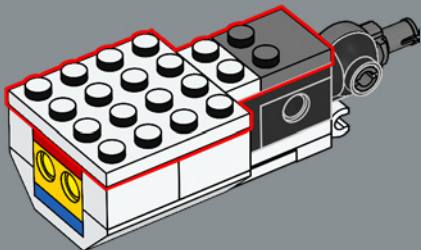

399

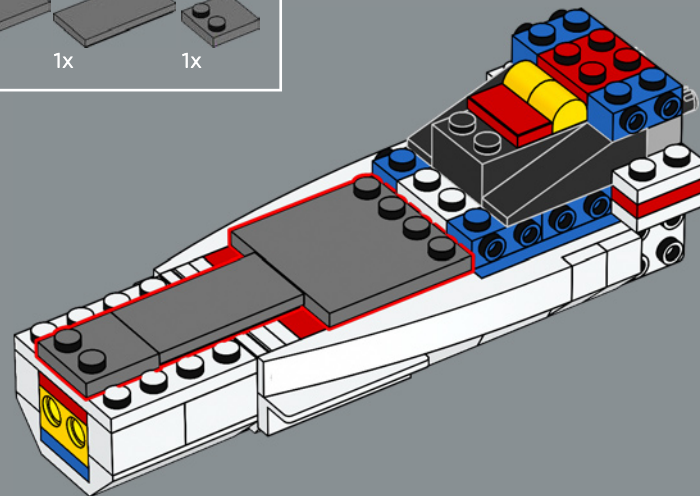

398

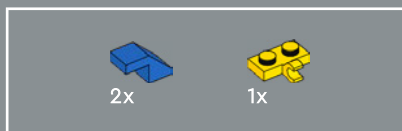
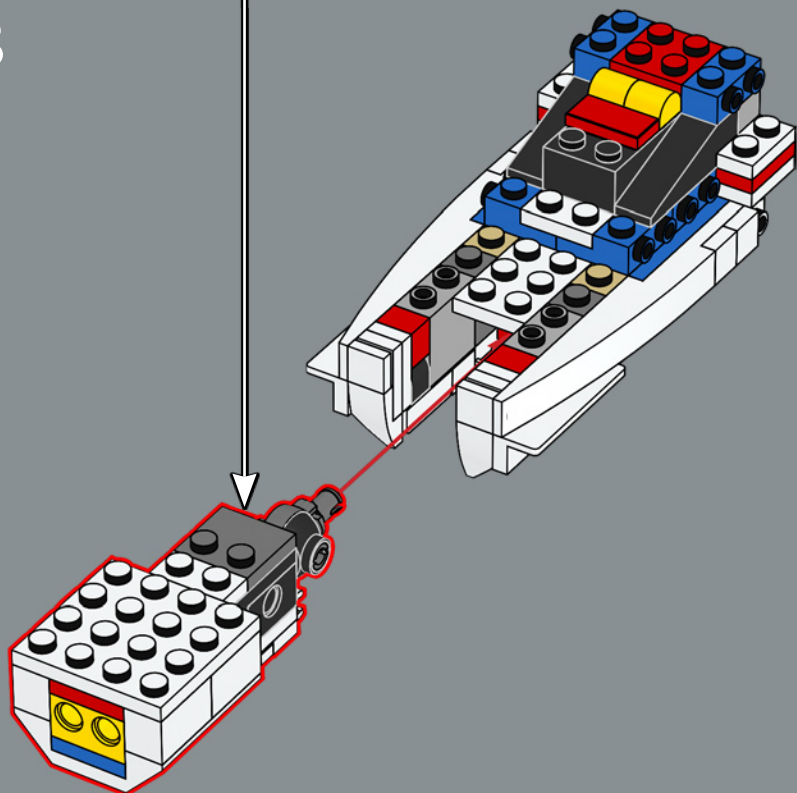

400

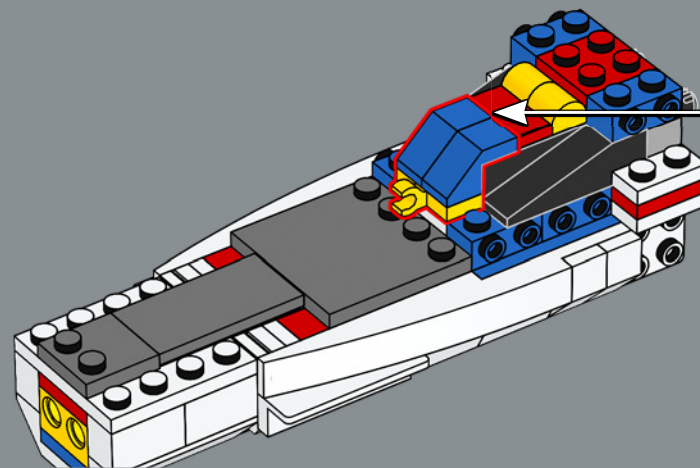
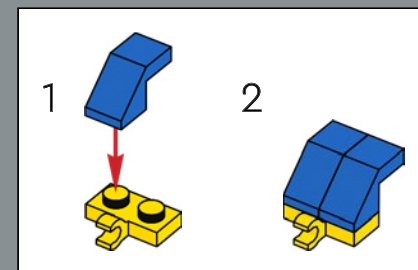

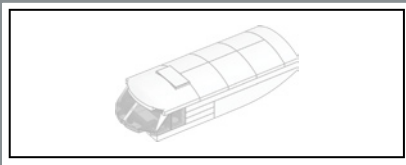

401

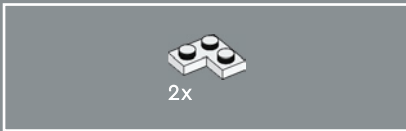
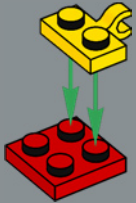

402

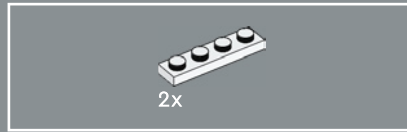

403

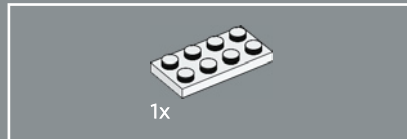
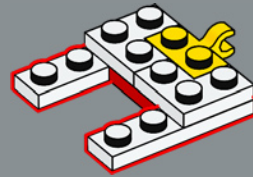

404

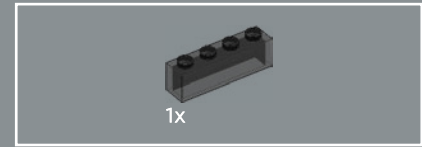
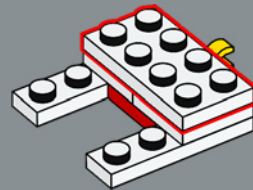

405

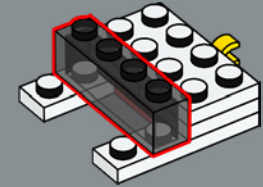

406



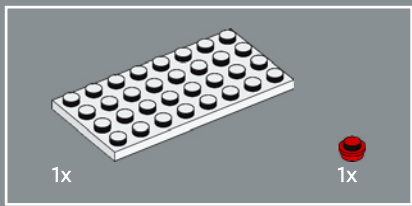

407

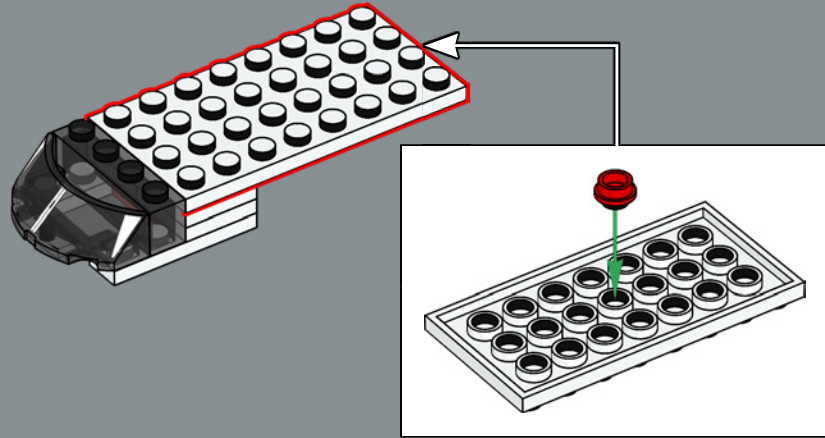

408

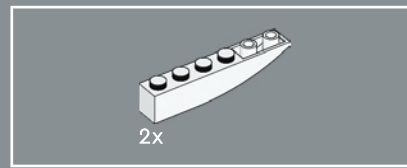
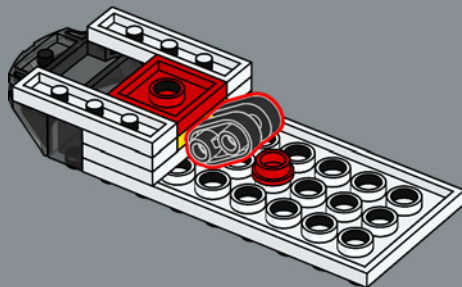

409

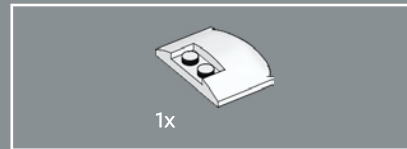
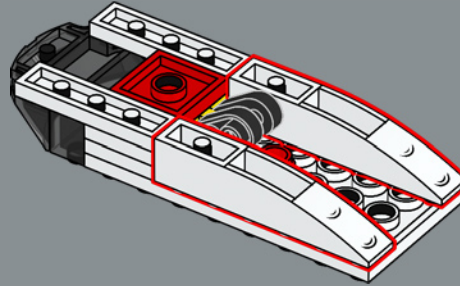

410

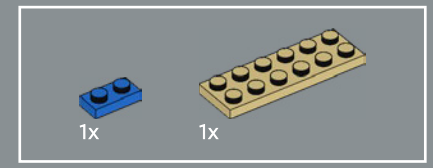
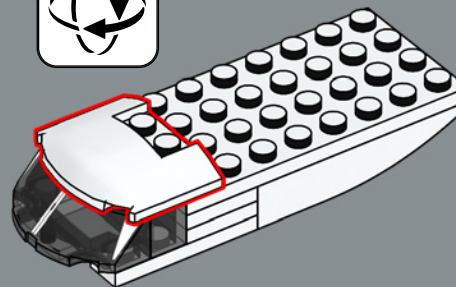

411

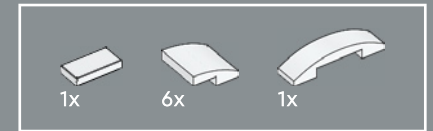
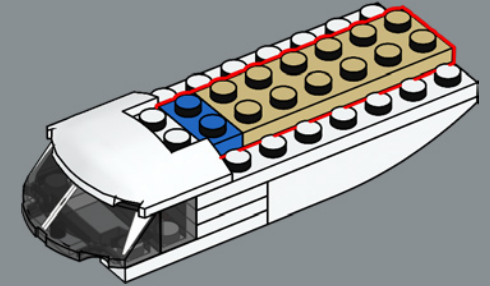

412

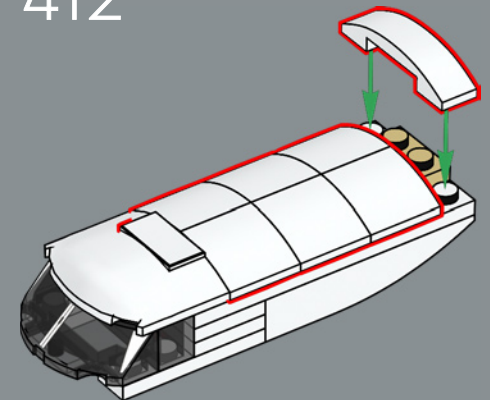

413

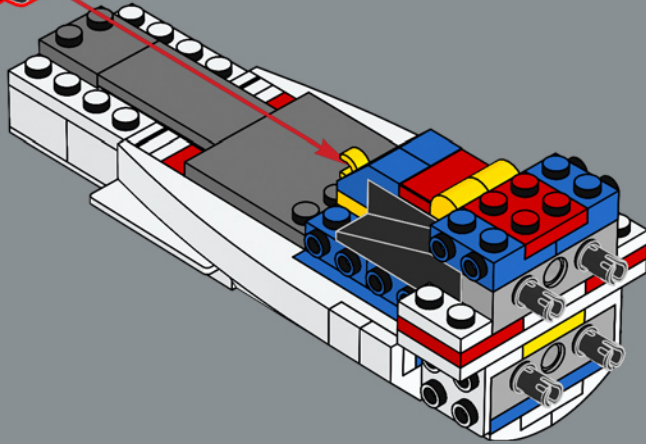
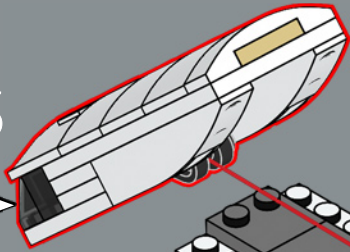

414

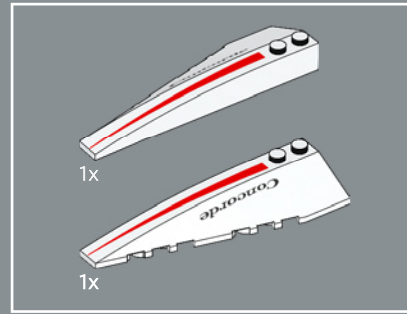
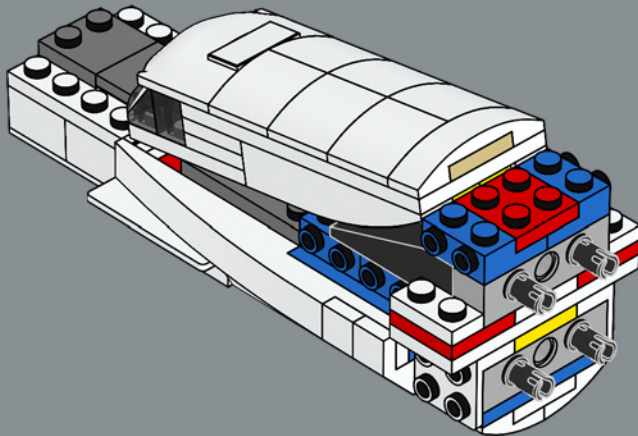

415

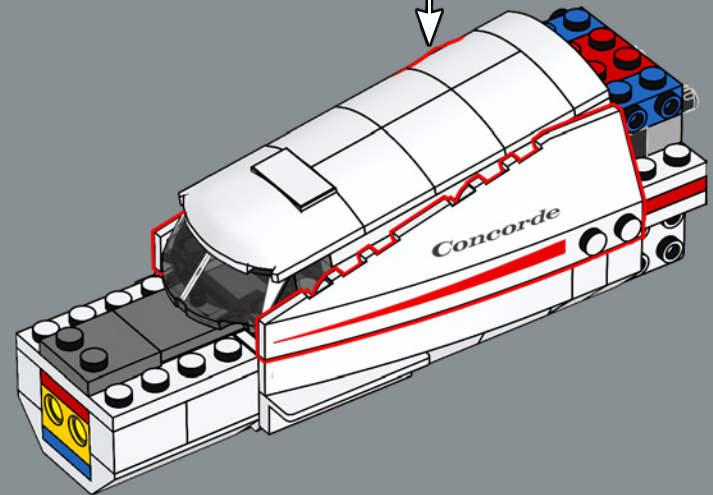
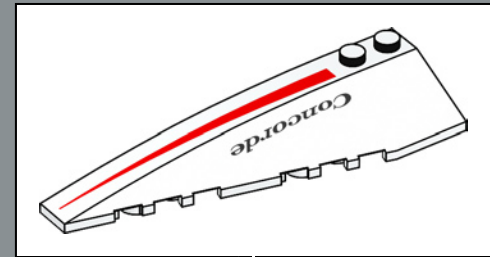



专为该模型开发了两个全新的乐高®组件：头锥和遮阳板。
协和式飞机的伸缩式遮阳板与机头一起向下折叠，会显露
出隐藏在后面的驾驶舱挡风玻璃。

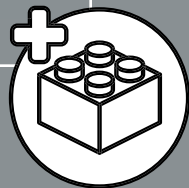
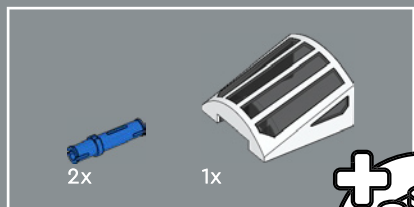

416

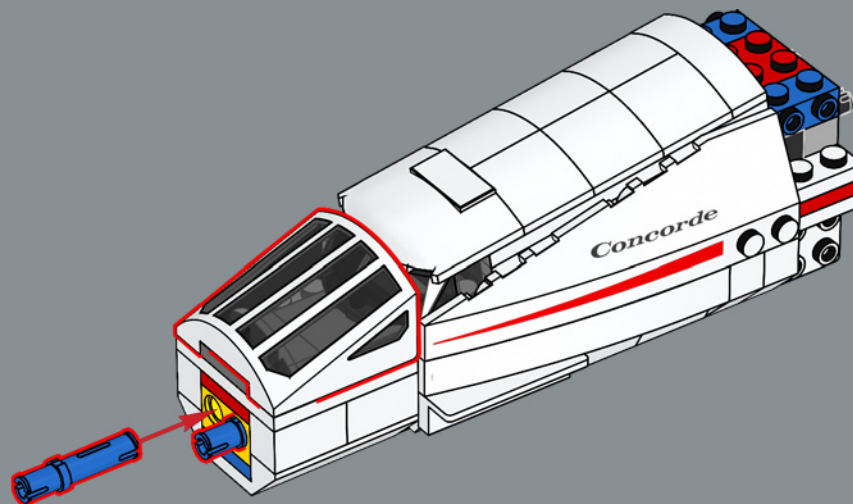

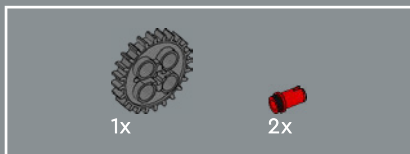

417

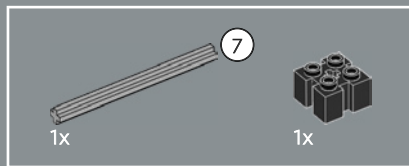
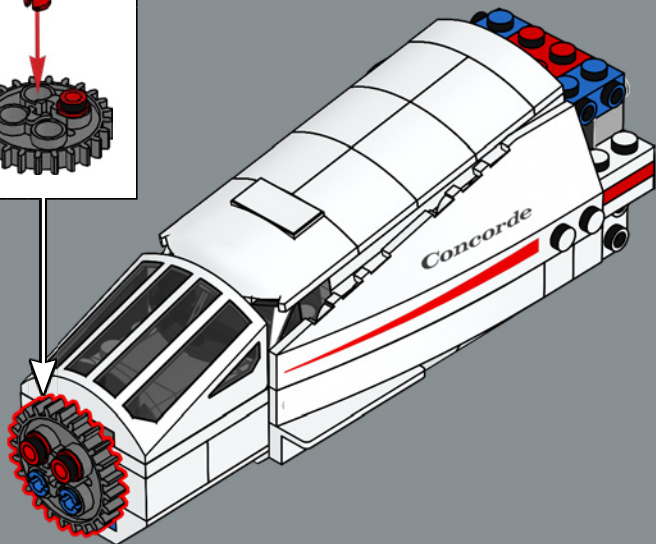
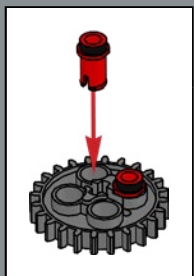

418

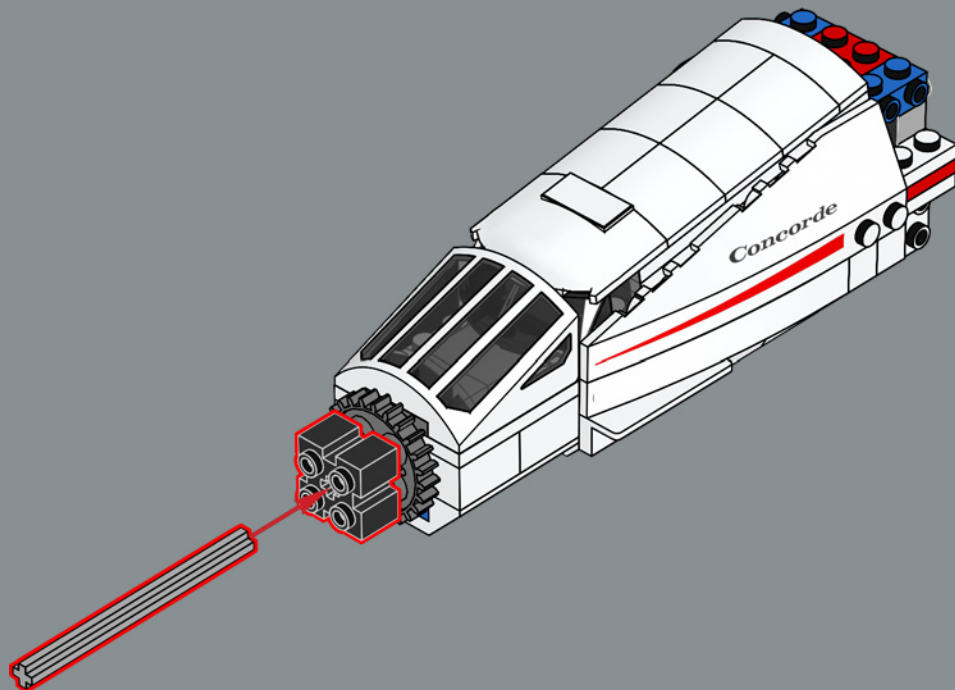



协和式飞机的长机头和三角翼对于实现超音速至关重要，
但起飞和着陆时的高迎角和头锥的长度使飞行员难以看
到跑道。解决方案——标志性的可下垂式头锥！

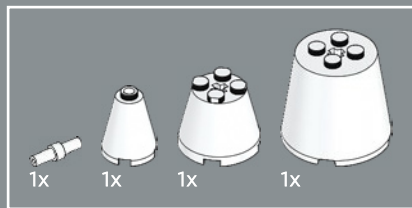

419

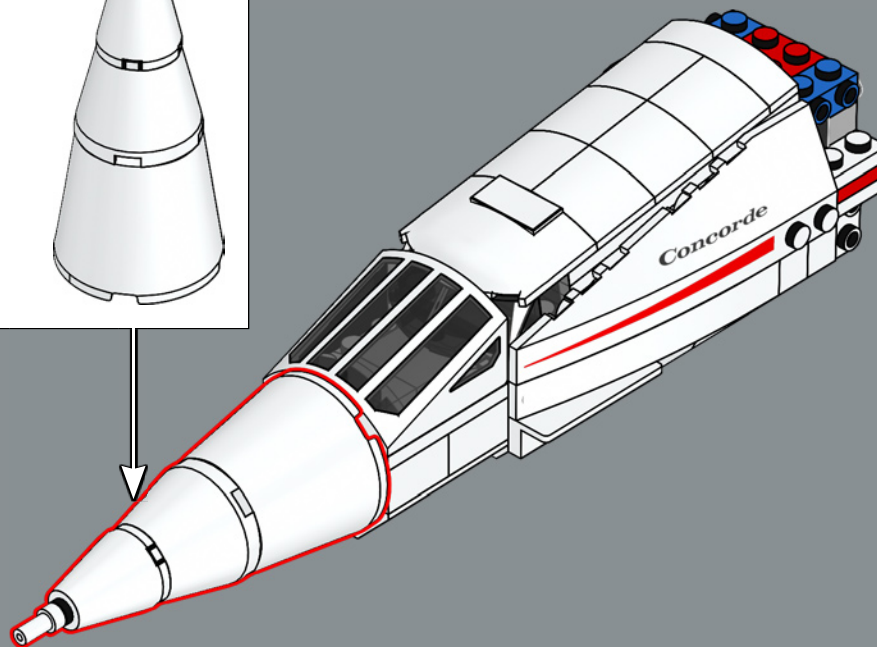
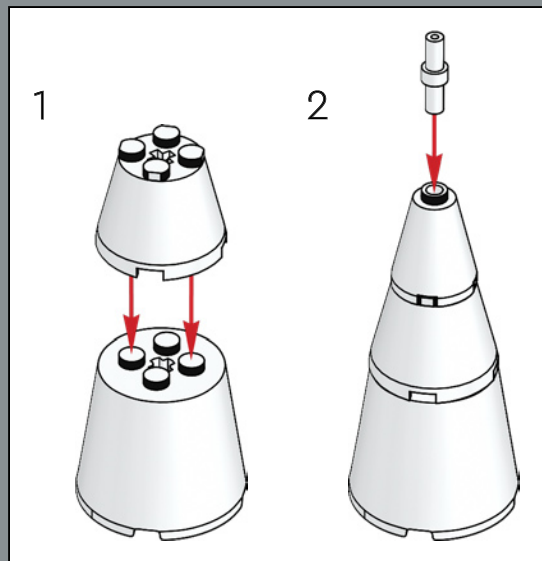

420

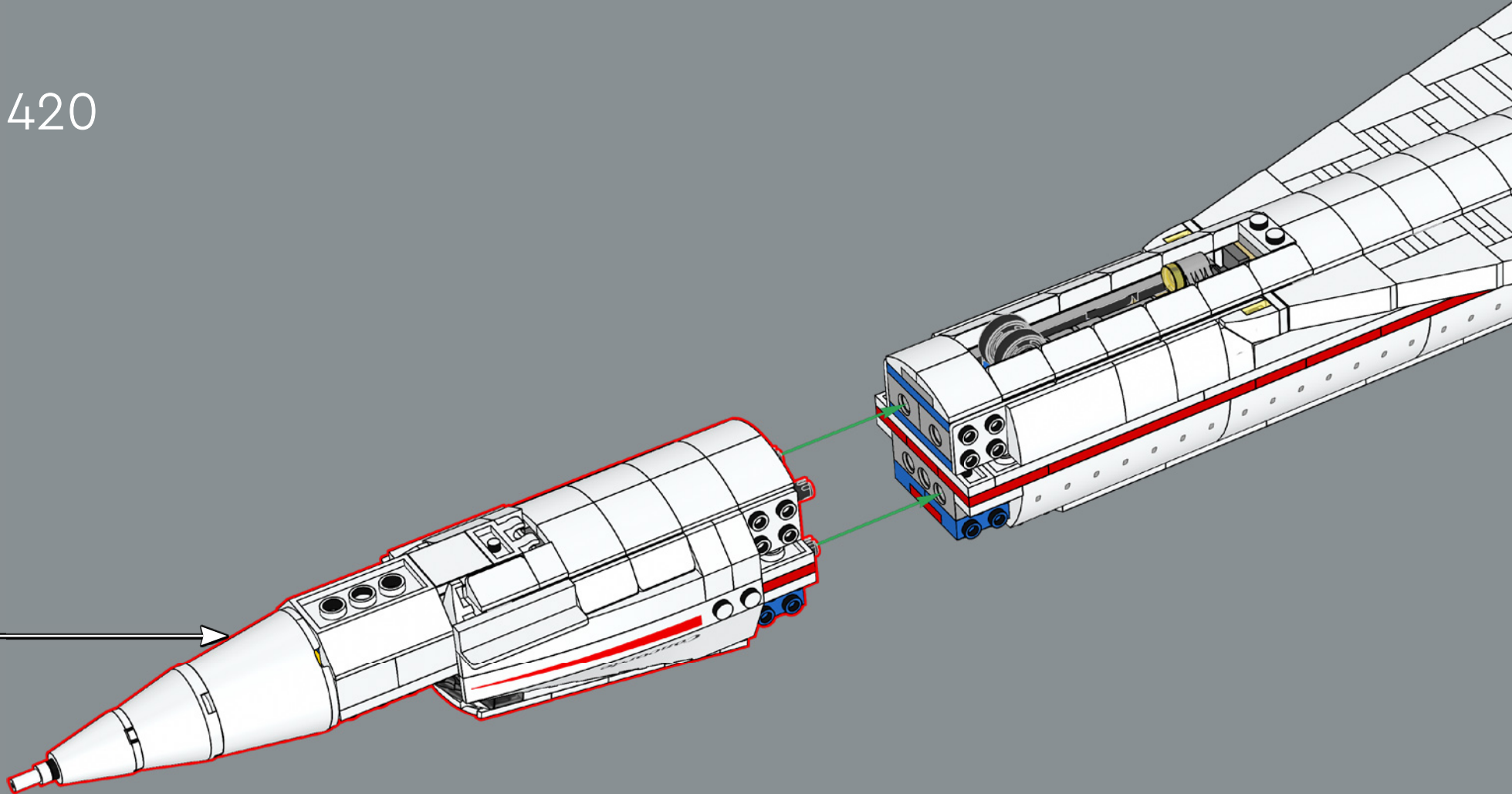

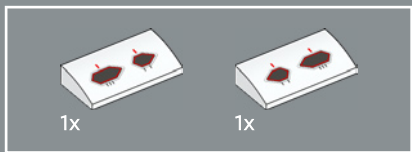

这些面板是静压孔，为飞机提供静态气压数据。

421

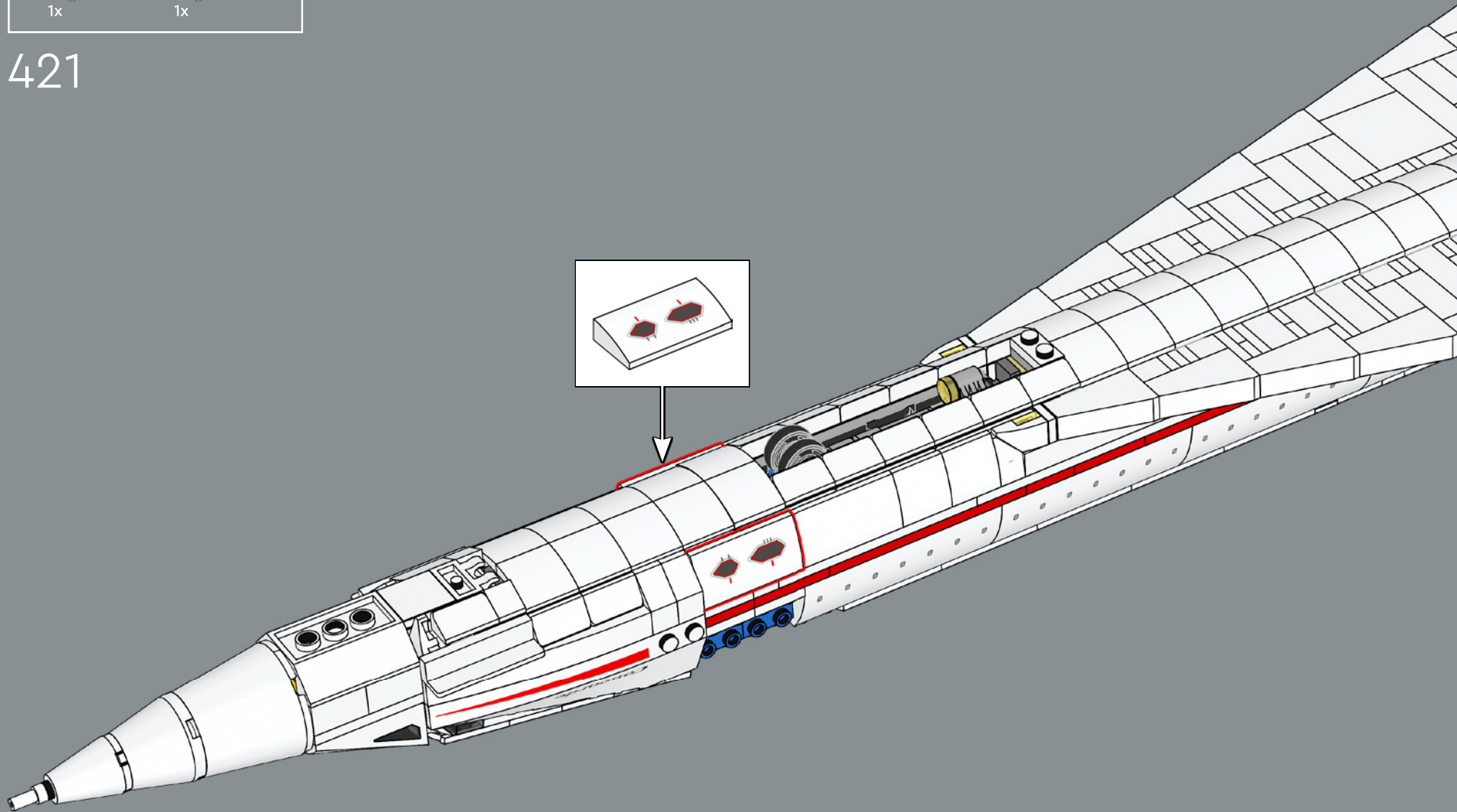



422

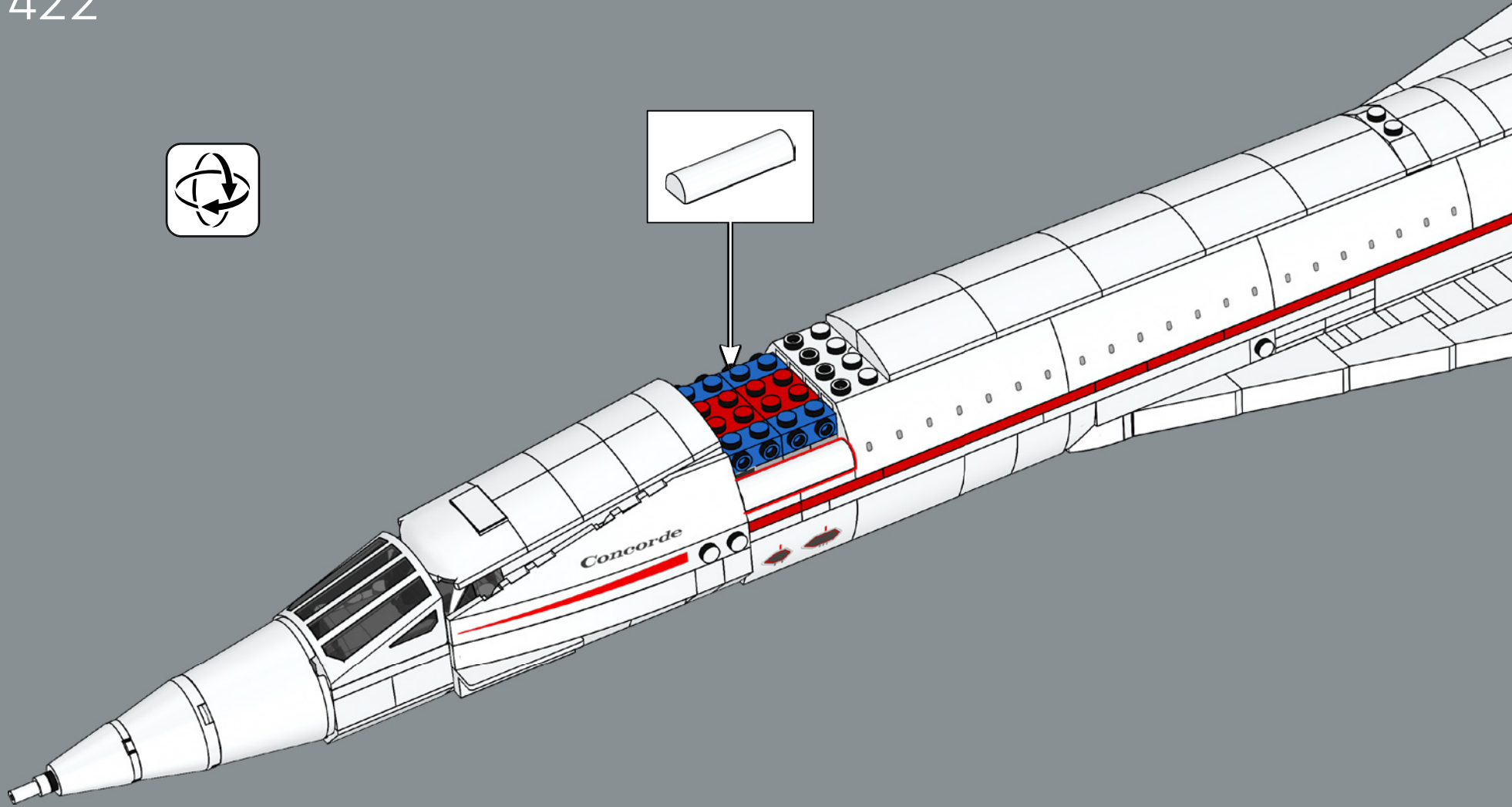
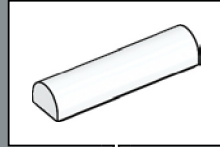

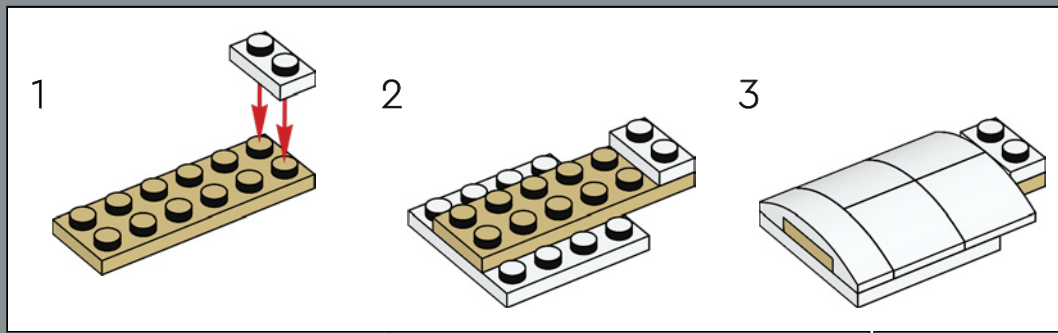
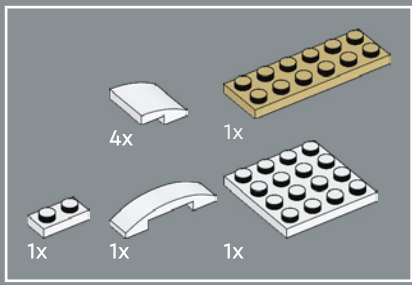

423

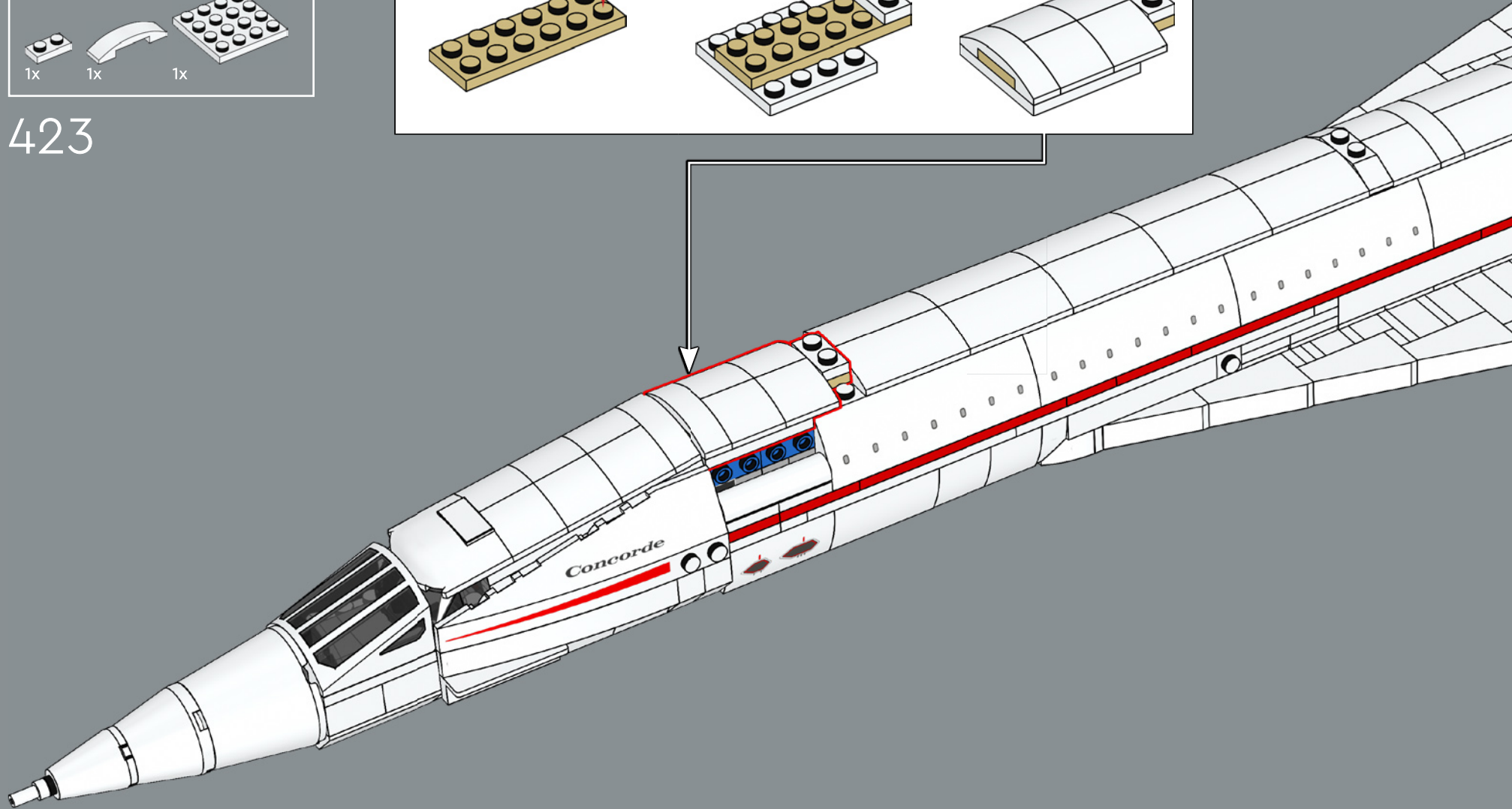

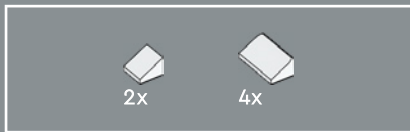

424

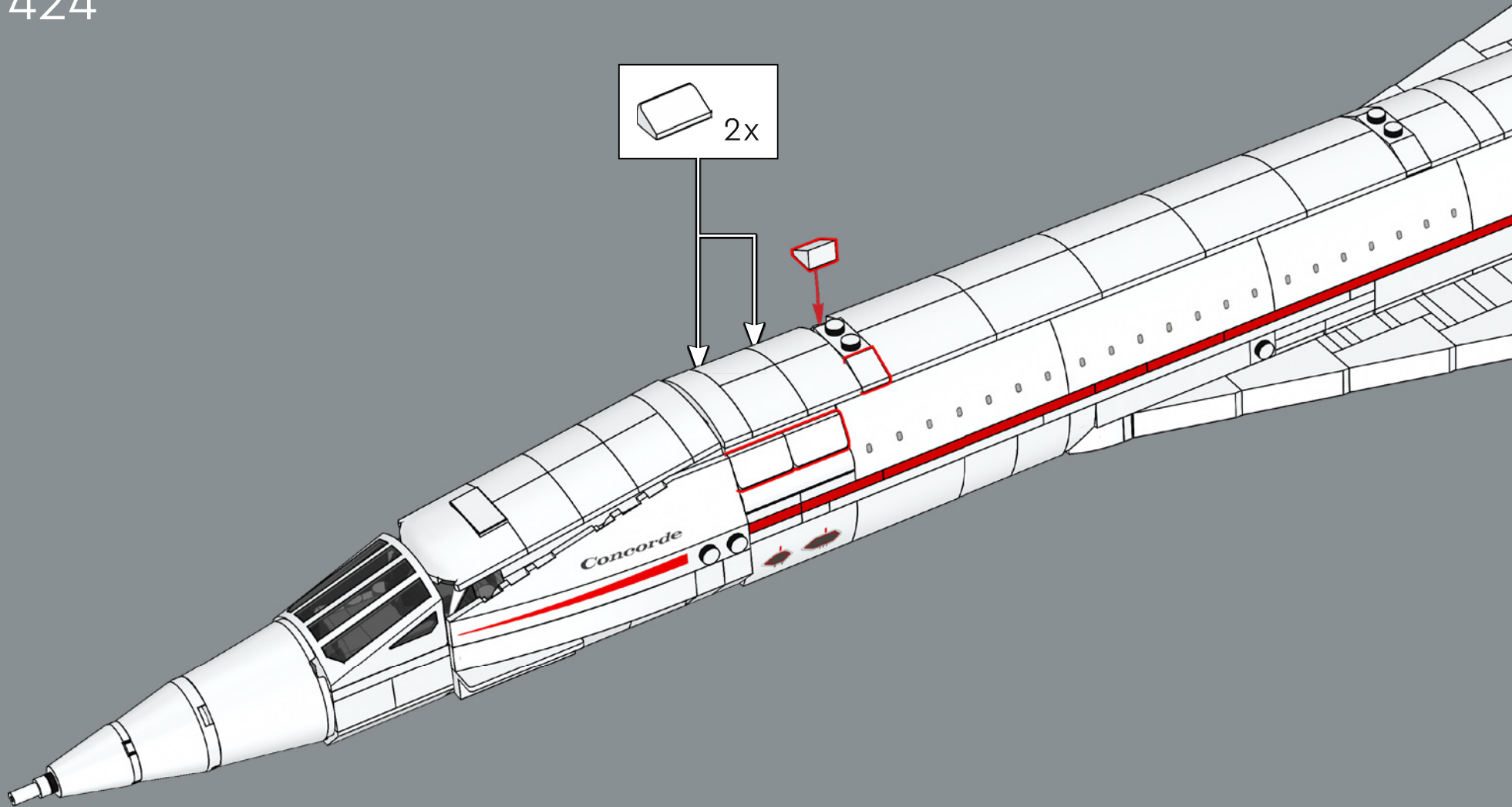
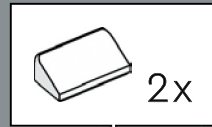

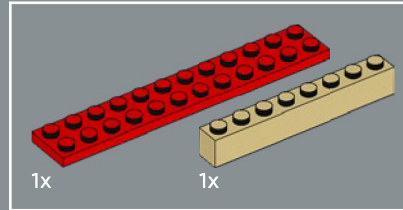
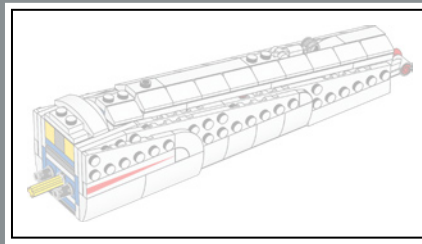

425

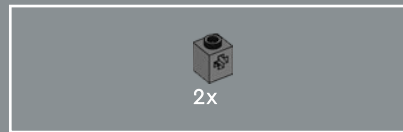
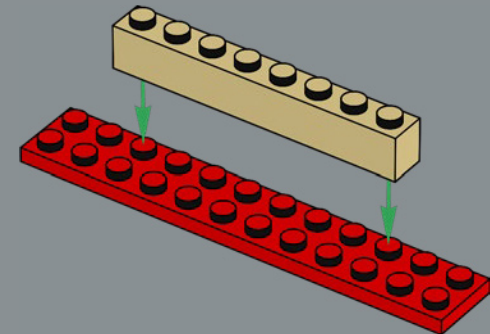

426

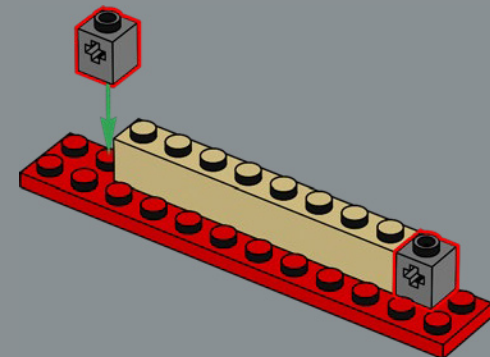

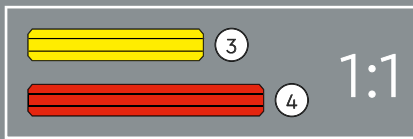
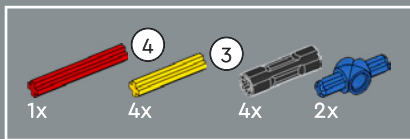

427

1

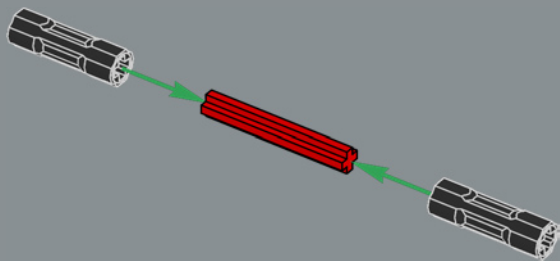

2

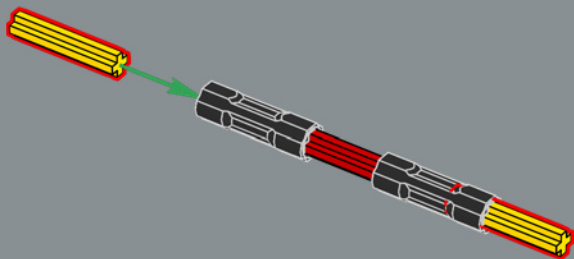

3

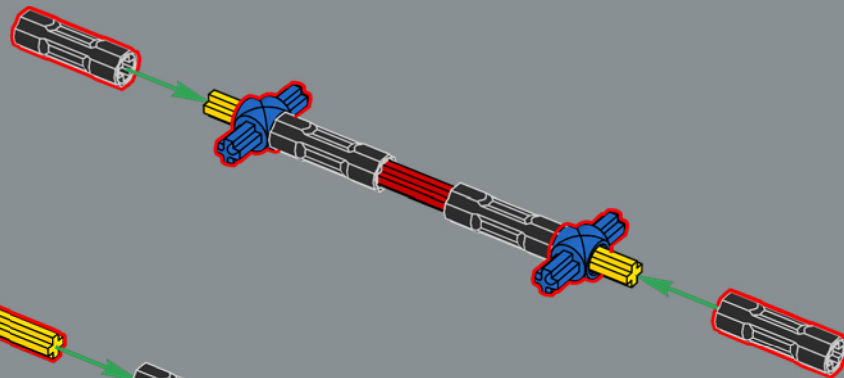

4

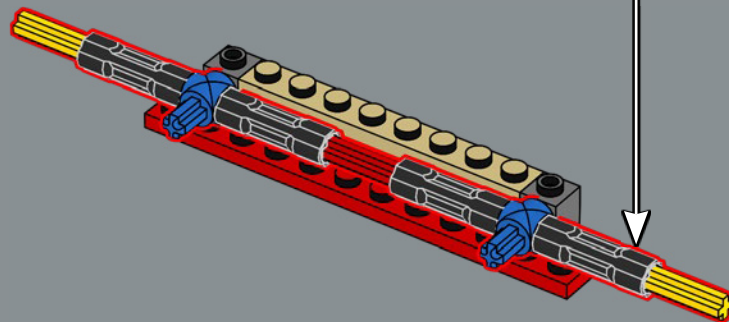
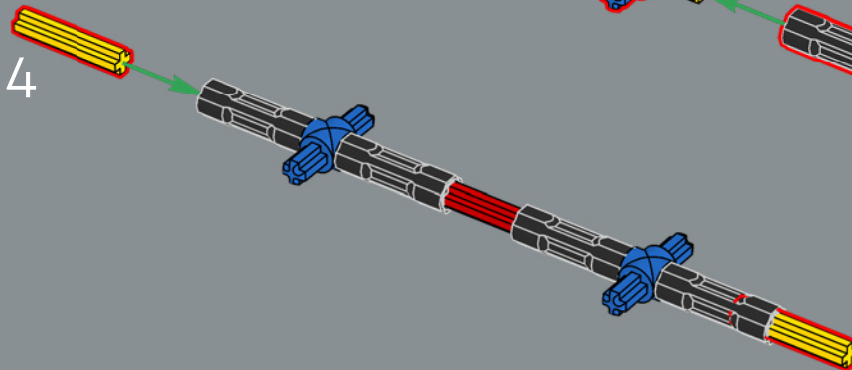

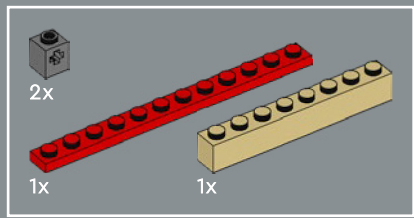

428

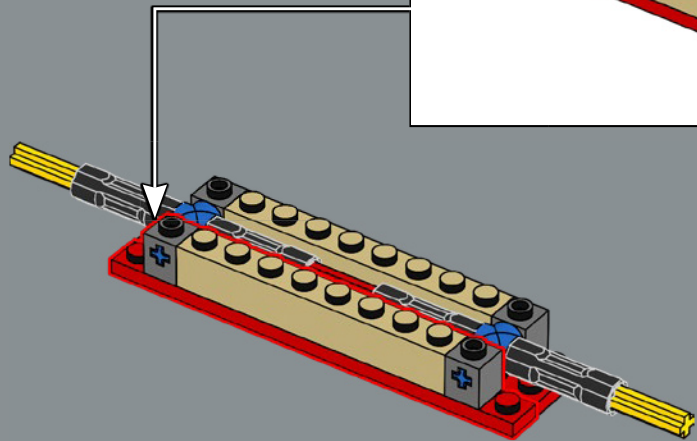
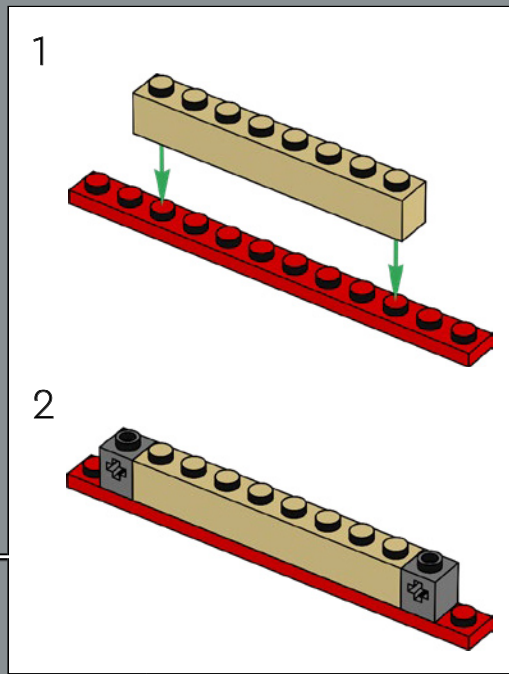

429

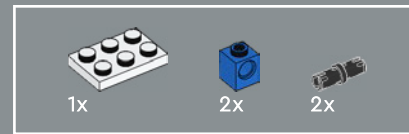
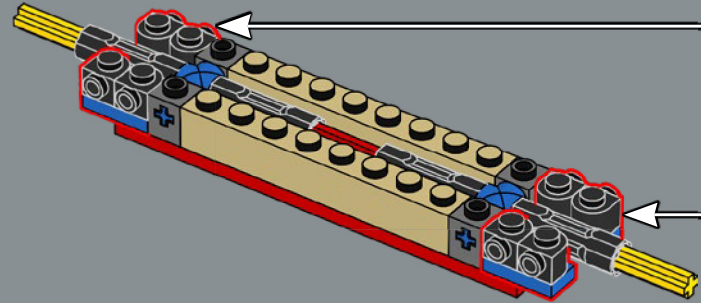
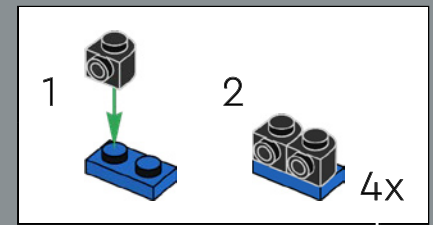

430

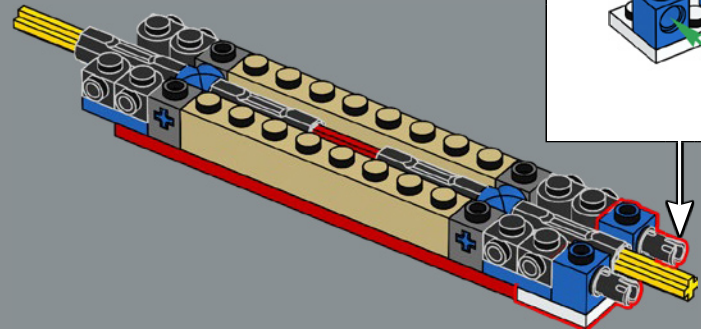
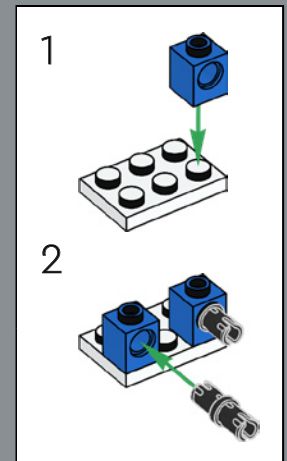

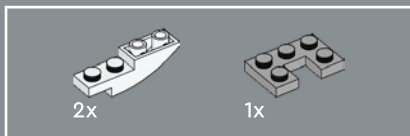

431

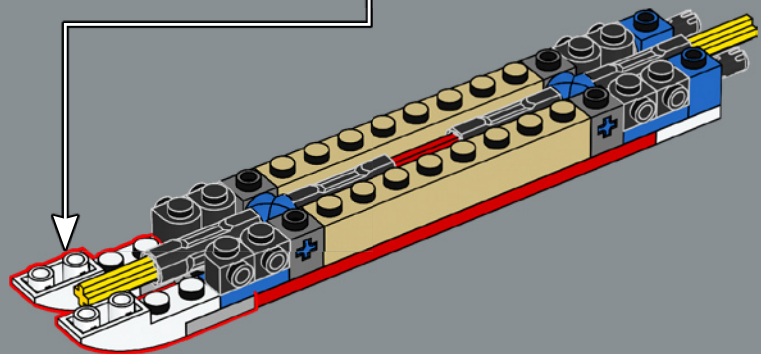
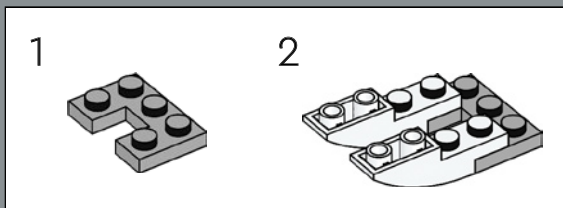

432

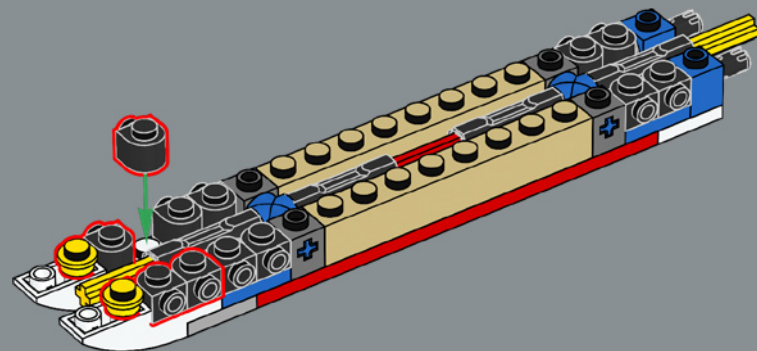



433

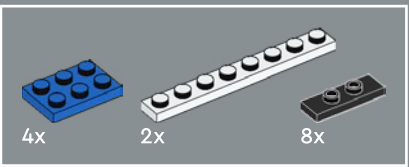
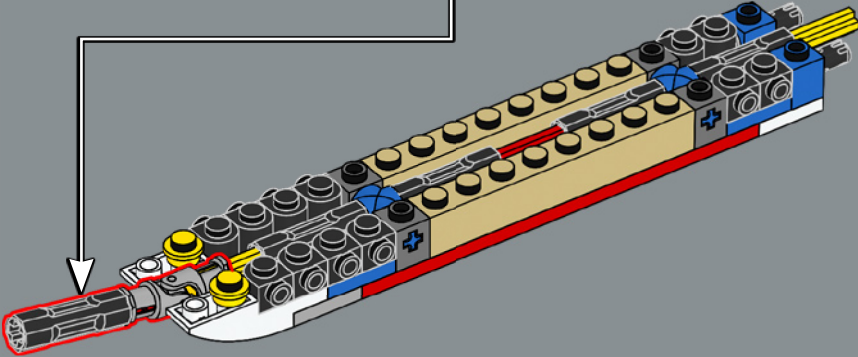
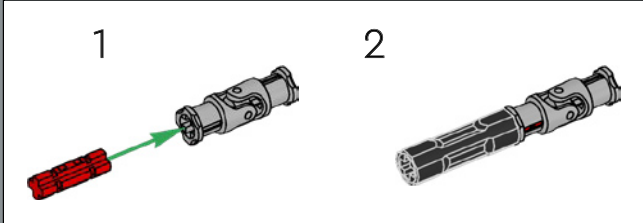

434

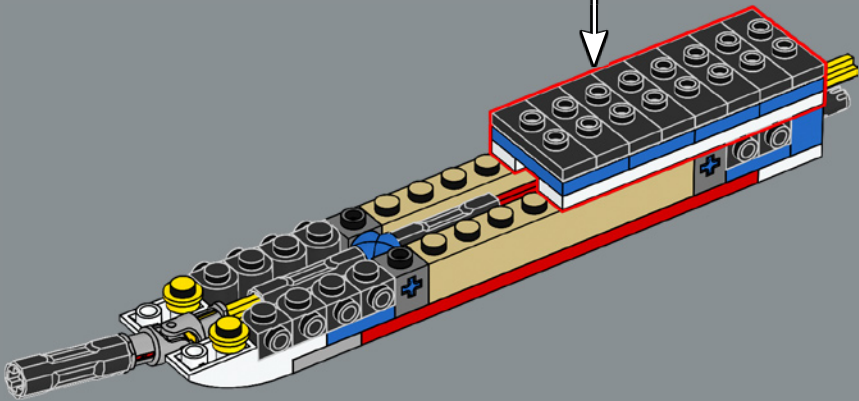
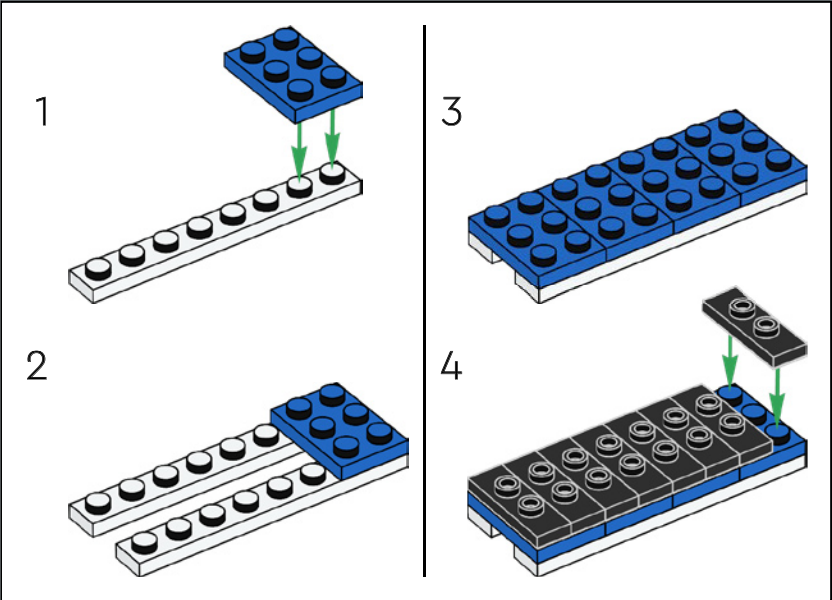

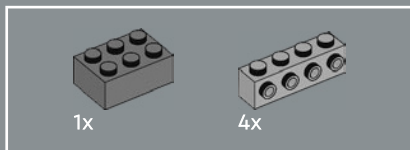

435



后部重心调整油箱是固定在飞机尾部的油箱。协和式飞机的重心必须变化才能起飞和超音速巡航，因此飞行工程师通过在油箱之间转移燃料来调整飞机的重心。

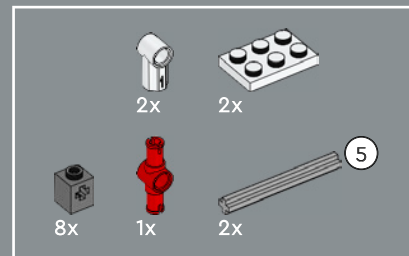

436

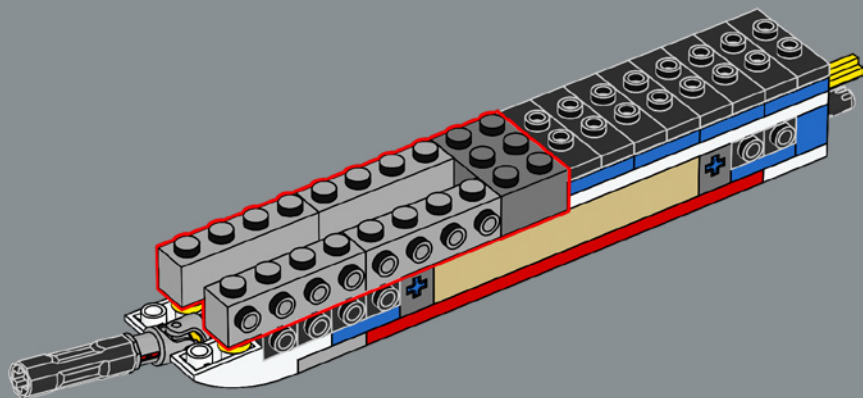
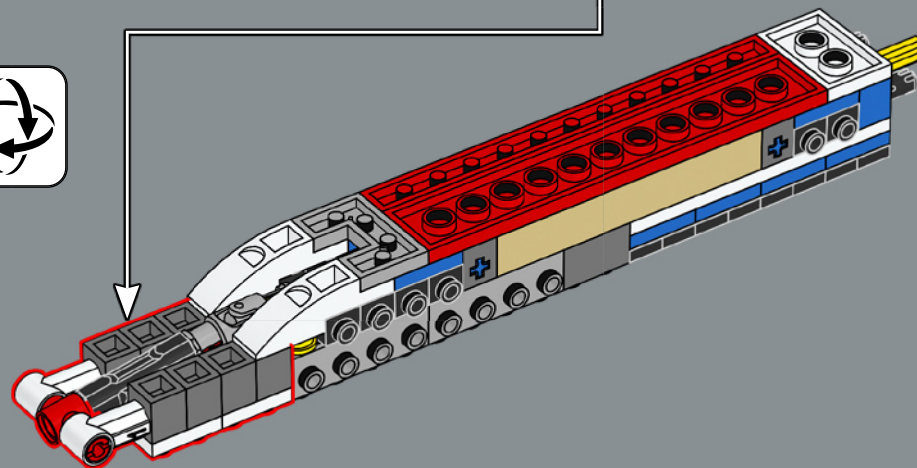
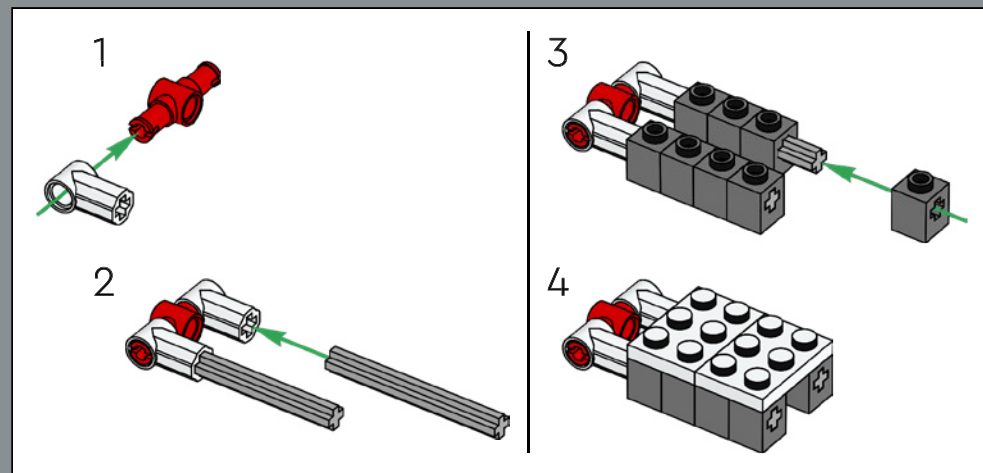

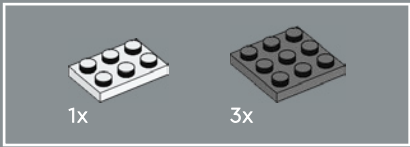

437

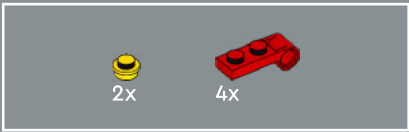
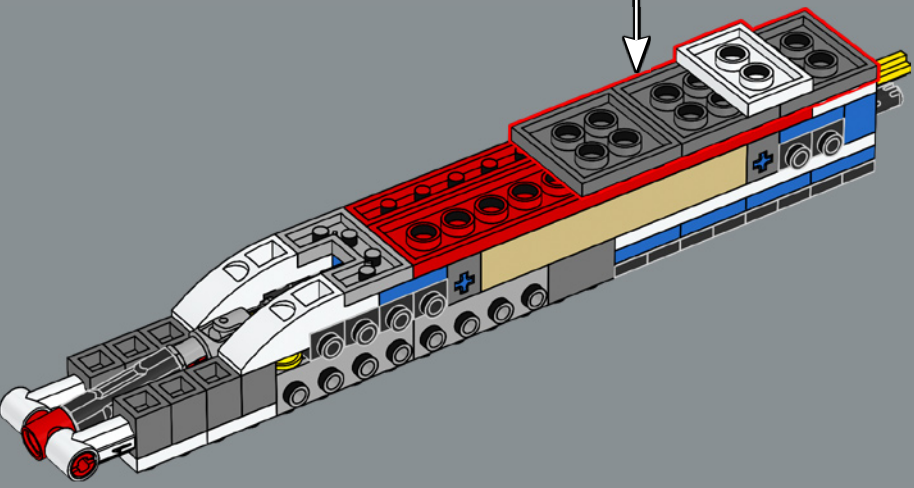
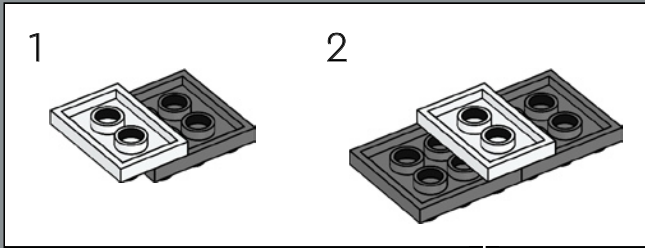

438

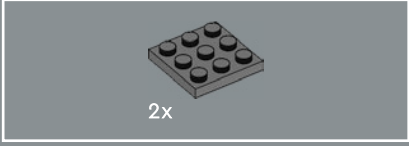
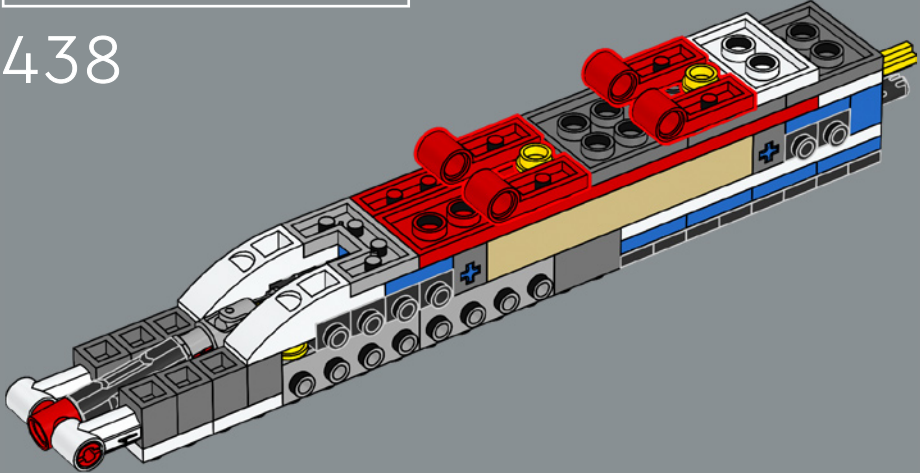

439

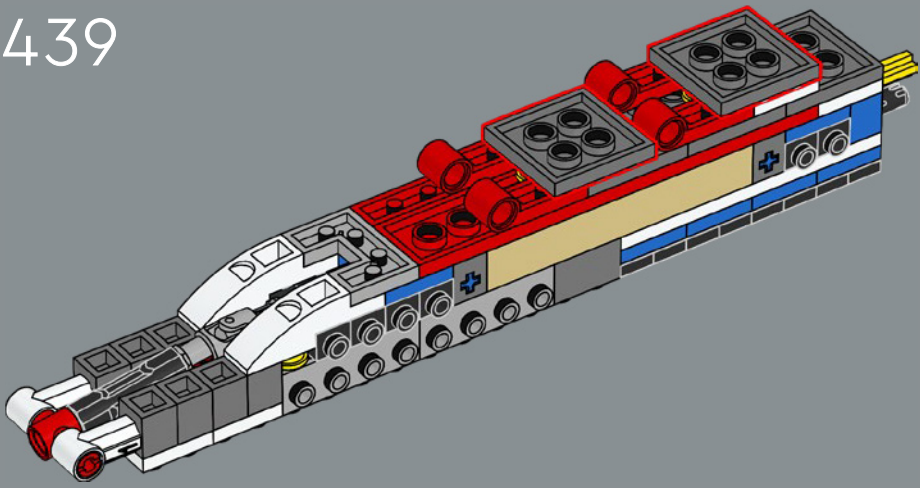

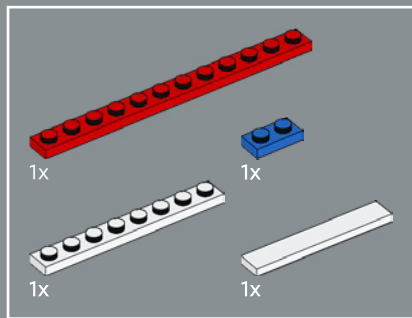

440

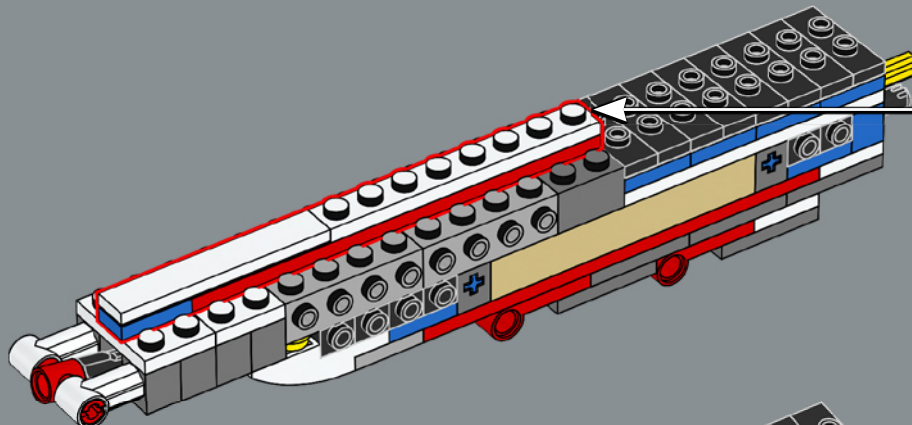
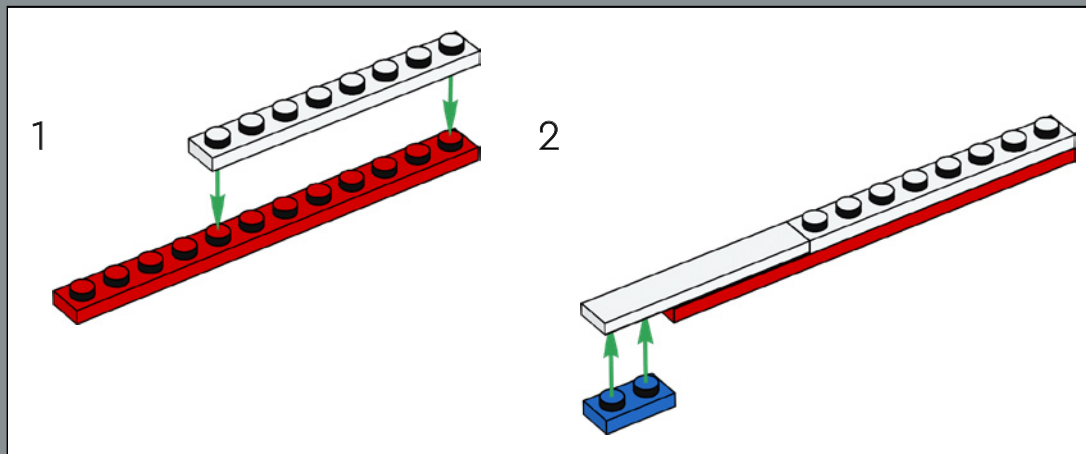

441

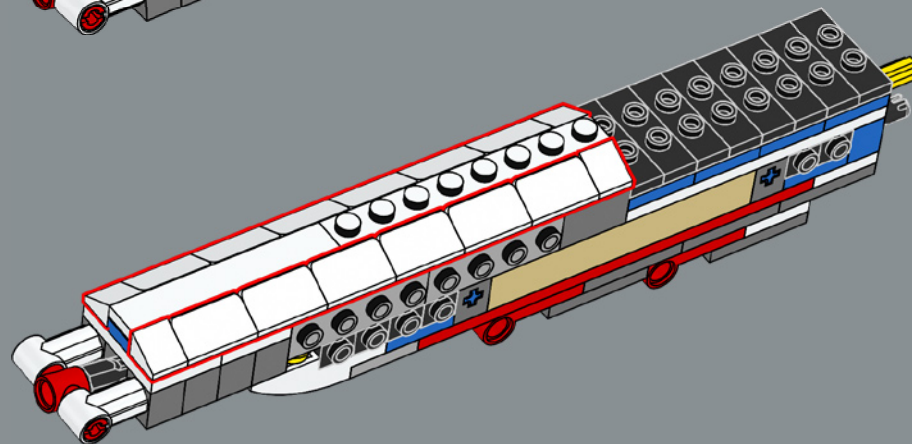



442

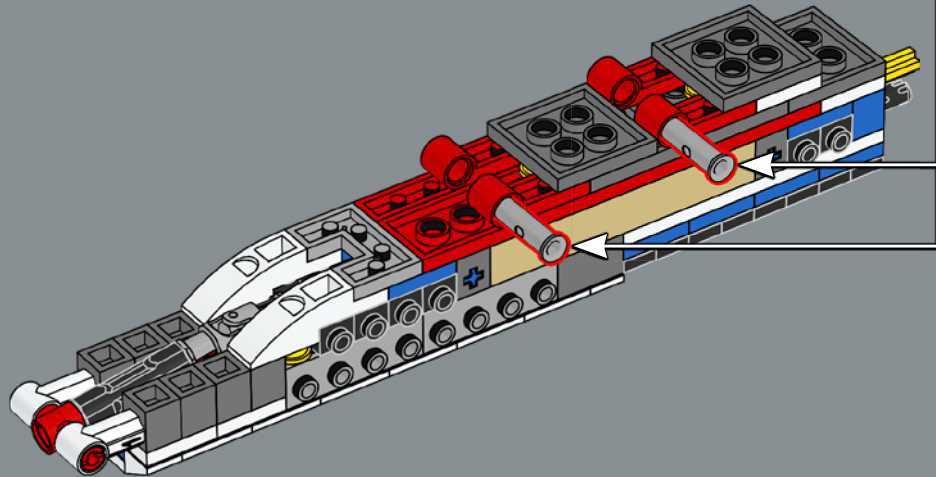

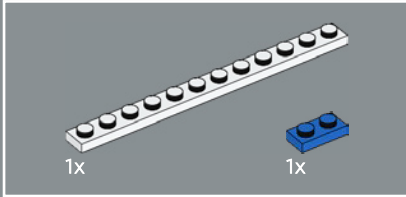
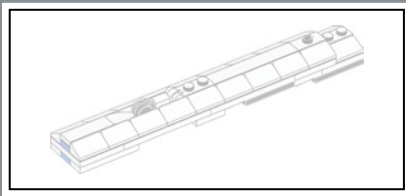

443

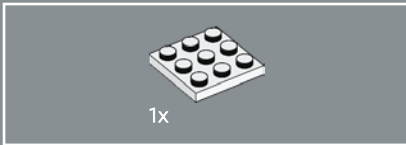
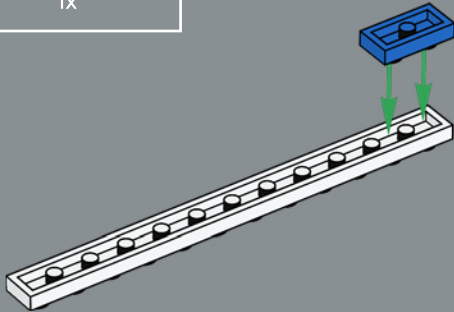

444

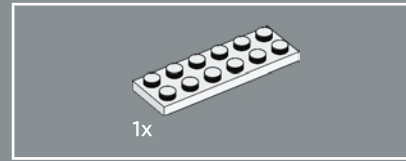
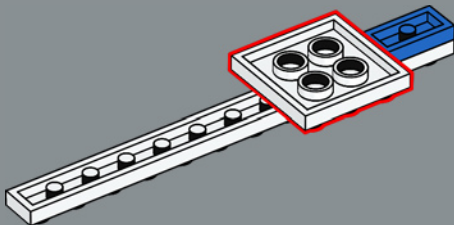

445

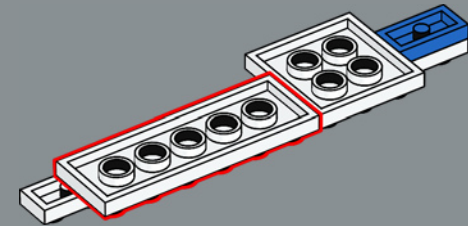

446

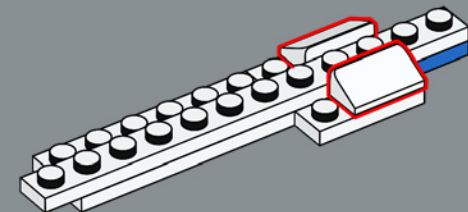



3x

447

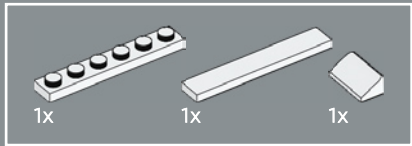
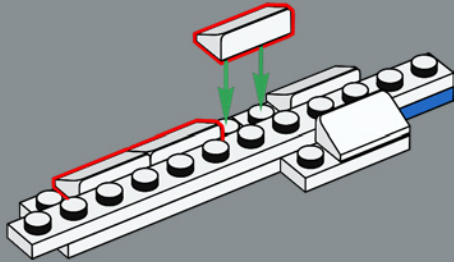

448

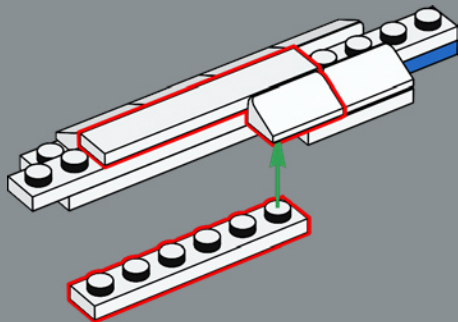

4x

449

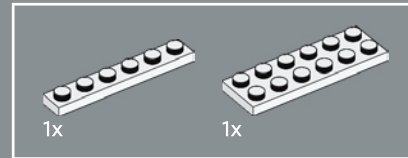
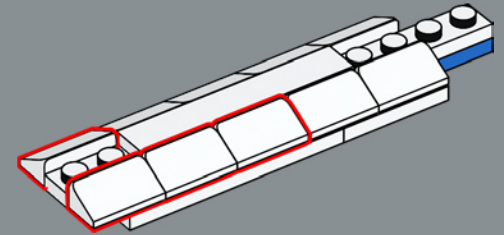

450

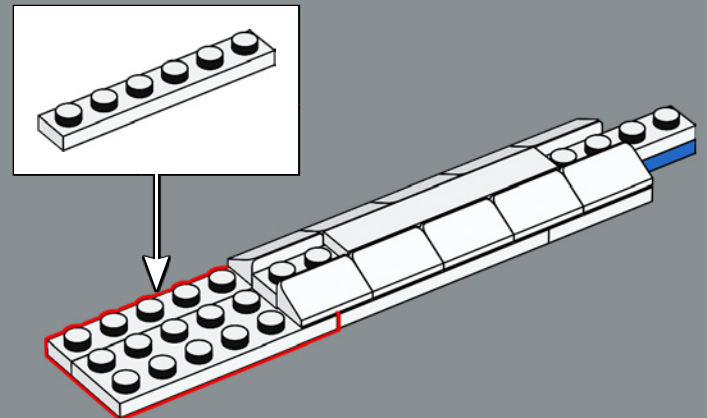

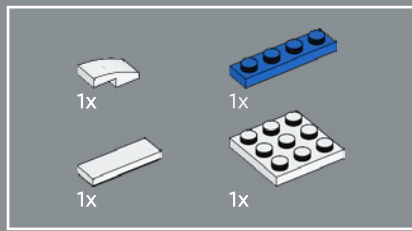

451

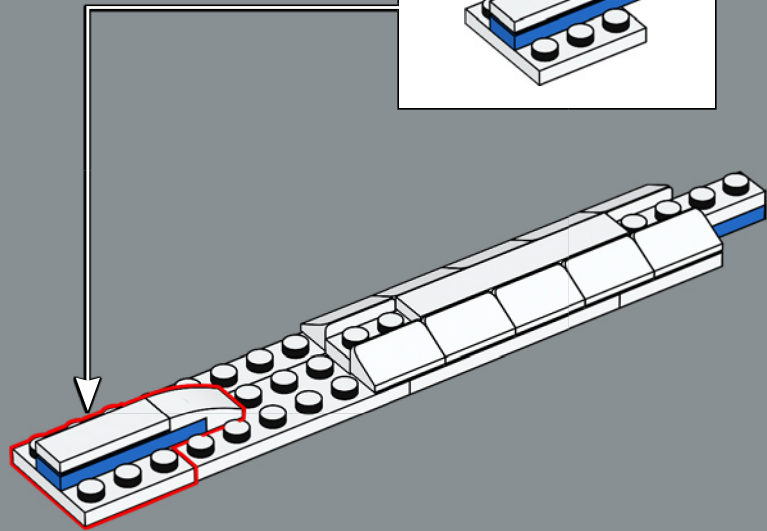
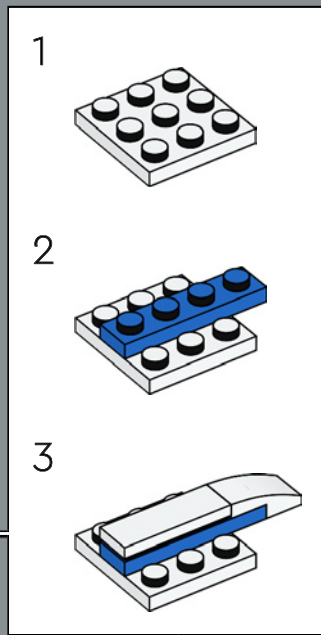

452

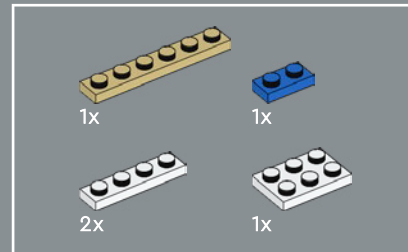
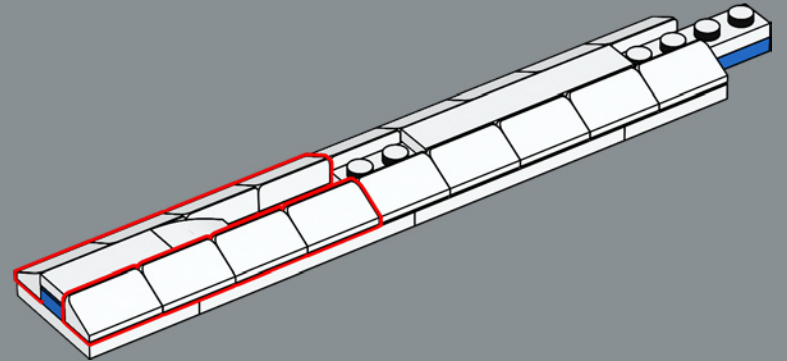

453

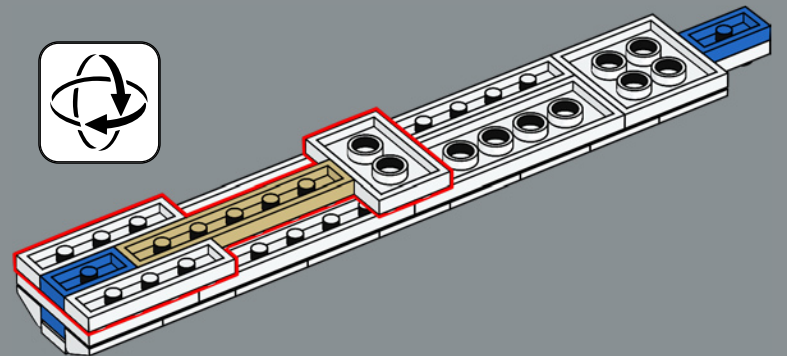

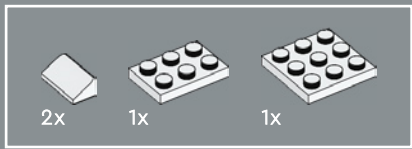

454

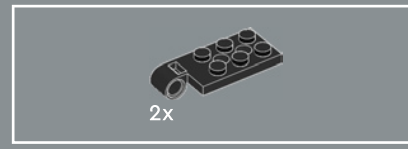
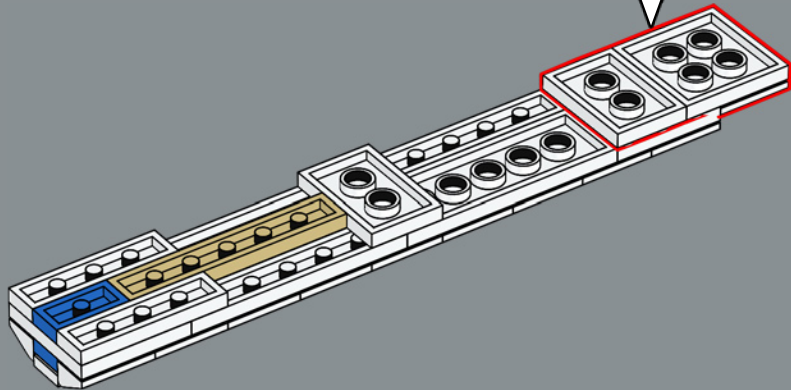
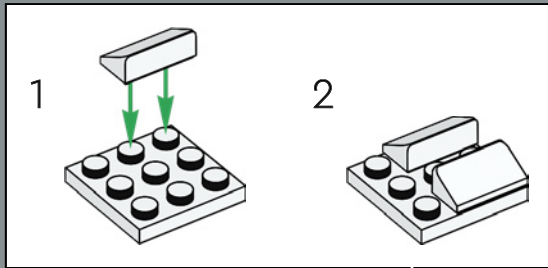

455

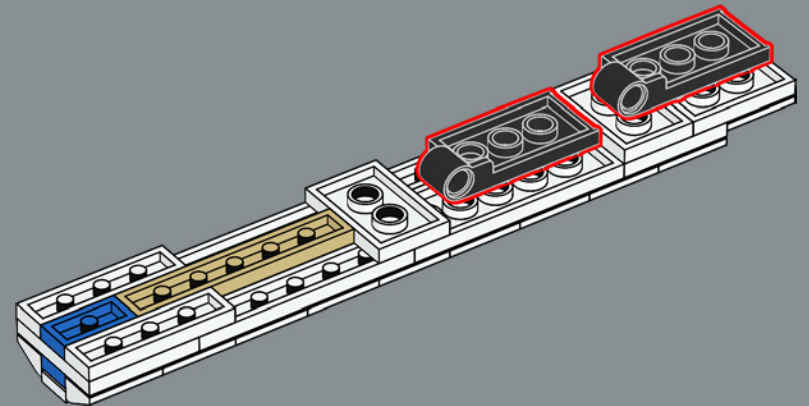

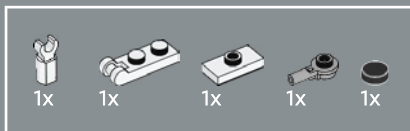

由于协和式飞机需要高迎角来优化三角翼在起飞和着陆时的升力，因此它带有一个小型的尾部缓冲轮，以确保飞机后部不会撞到地面。

456

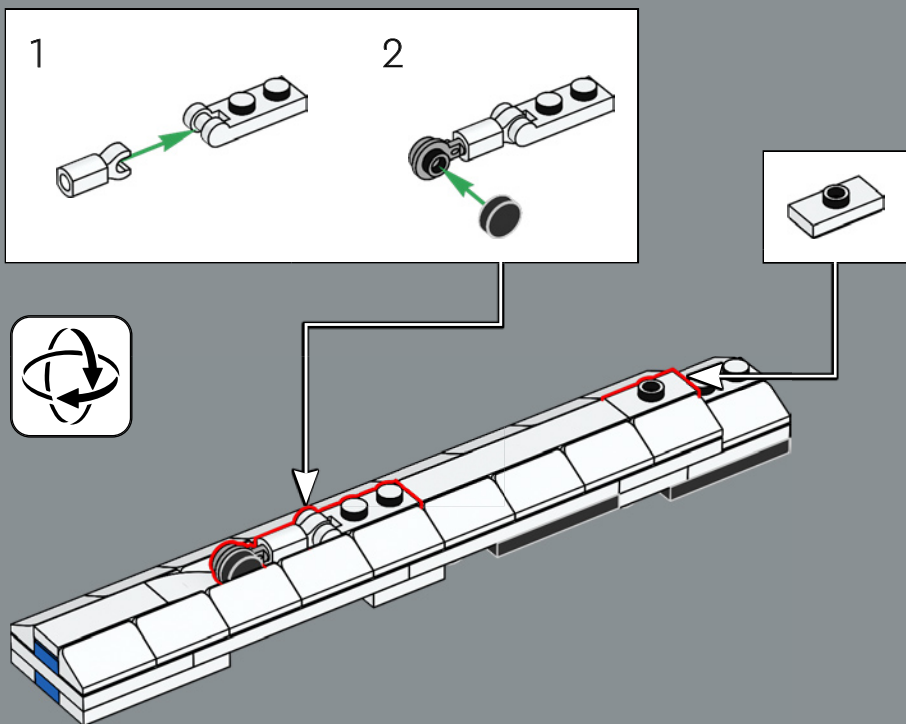

机尾底部在这里与三角形 (reflected triangle) 结构相连，实现了光滑的锥形，使协和式飞机如此具有标志性。

457

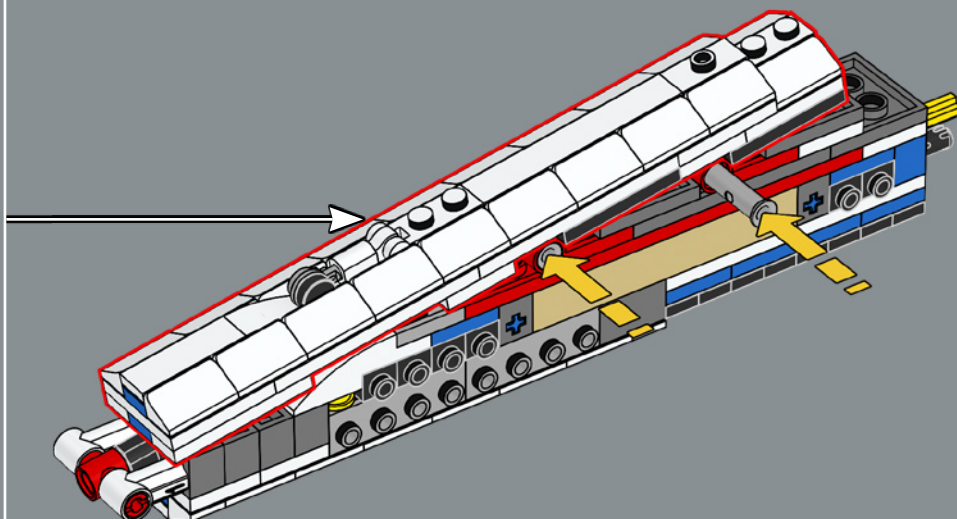

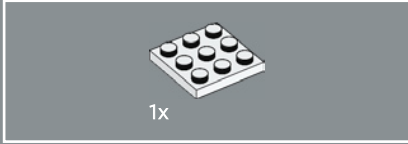
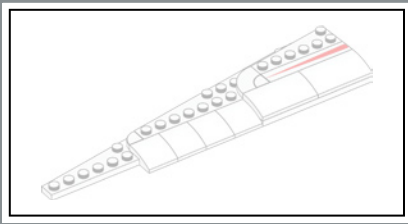

1x

458



1x

459

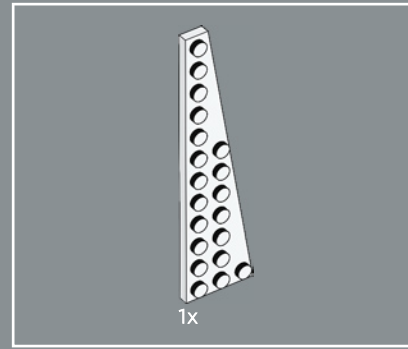
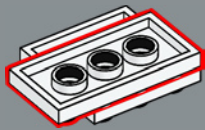

1x

460

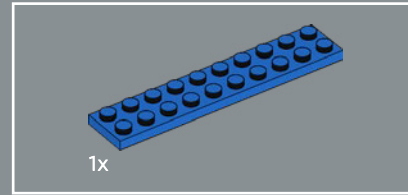
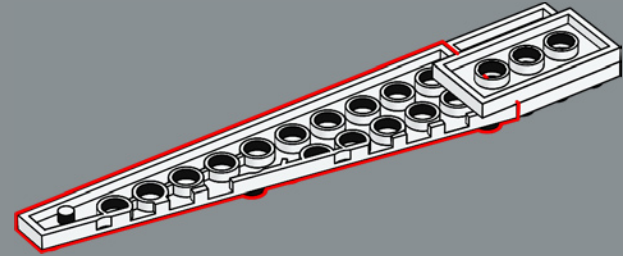

1x

461

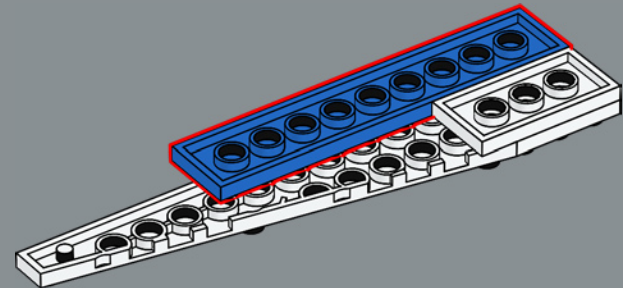

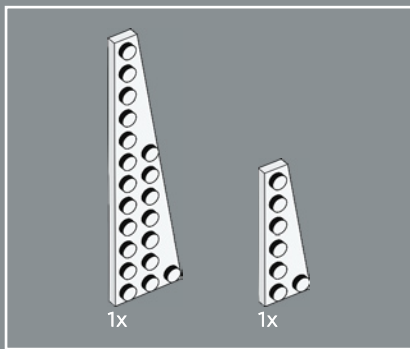

462

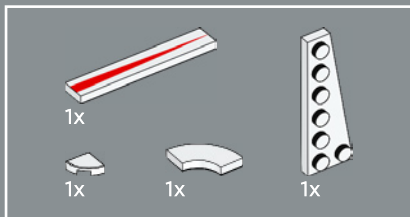
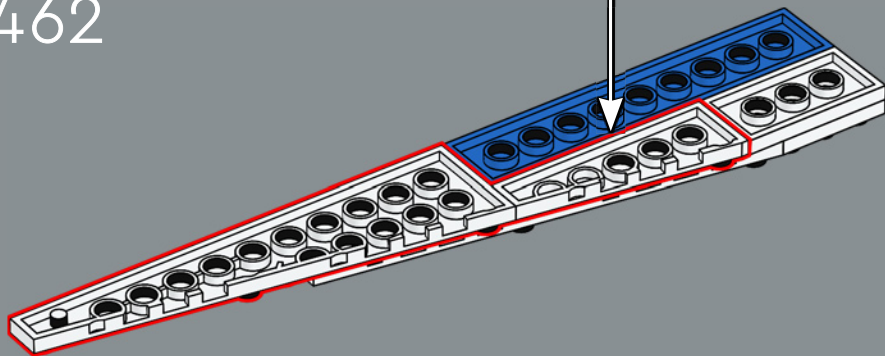
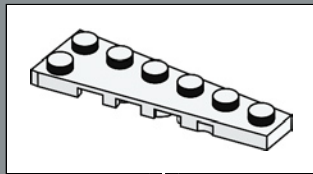

463

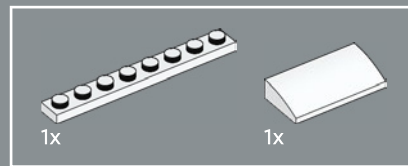
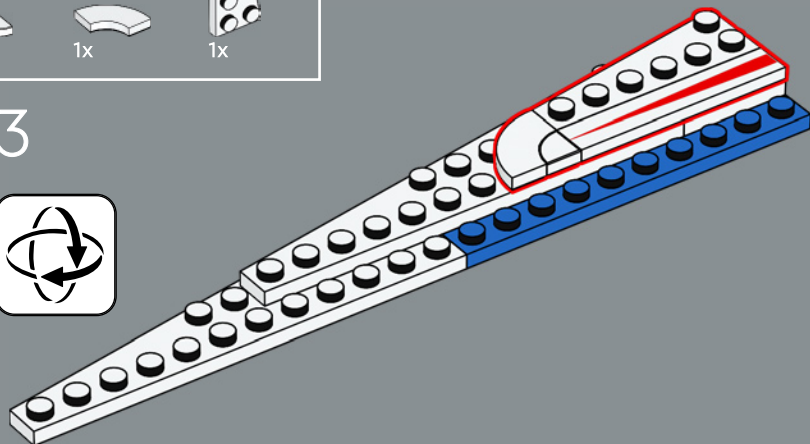

464

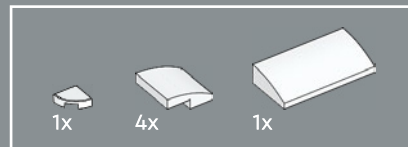
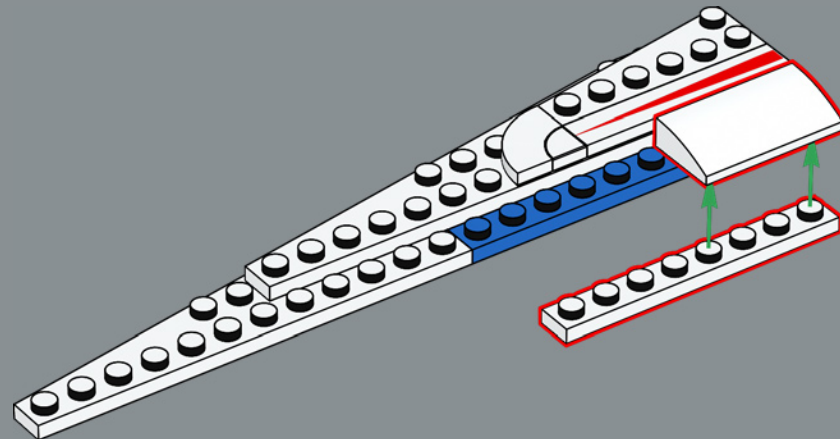

465

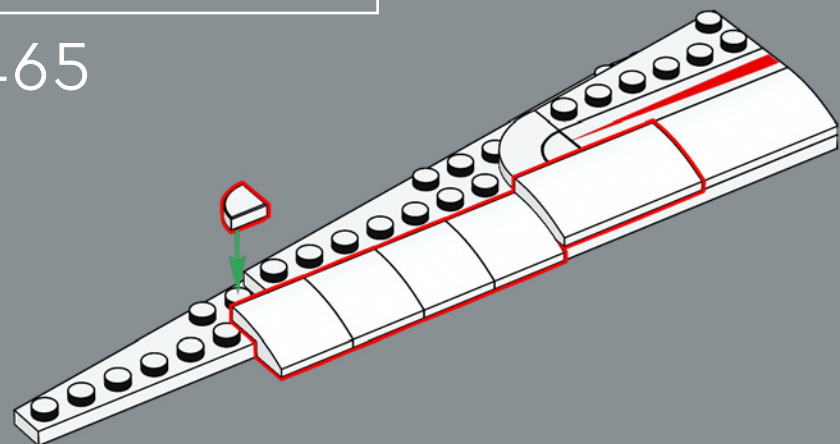

466

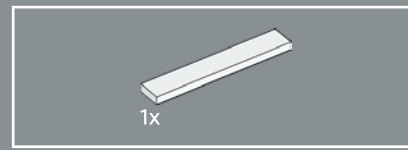
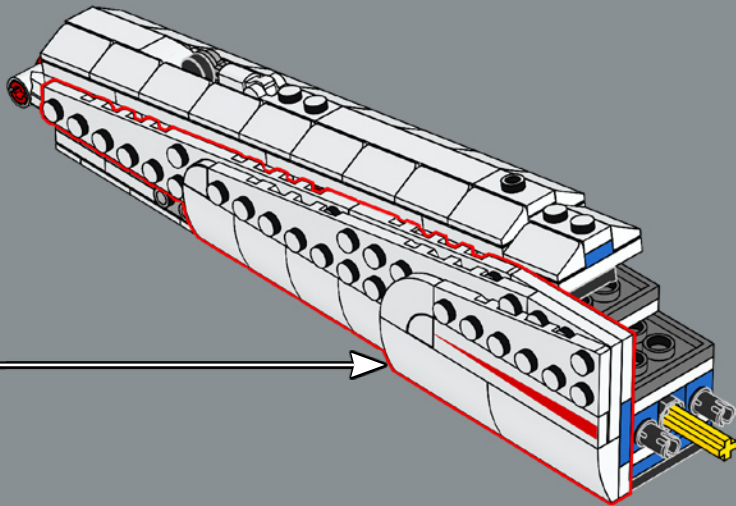

467

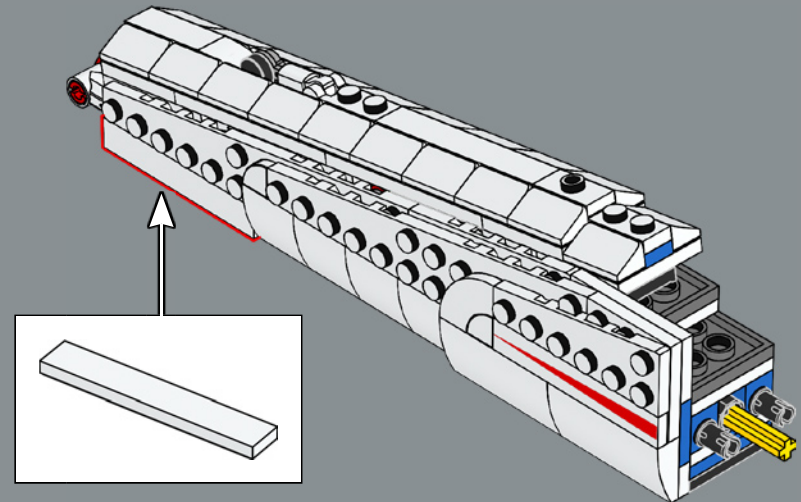

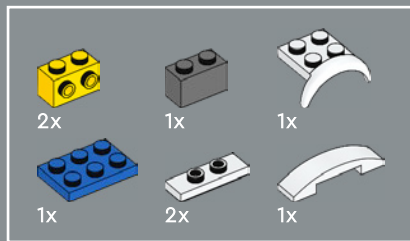

468

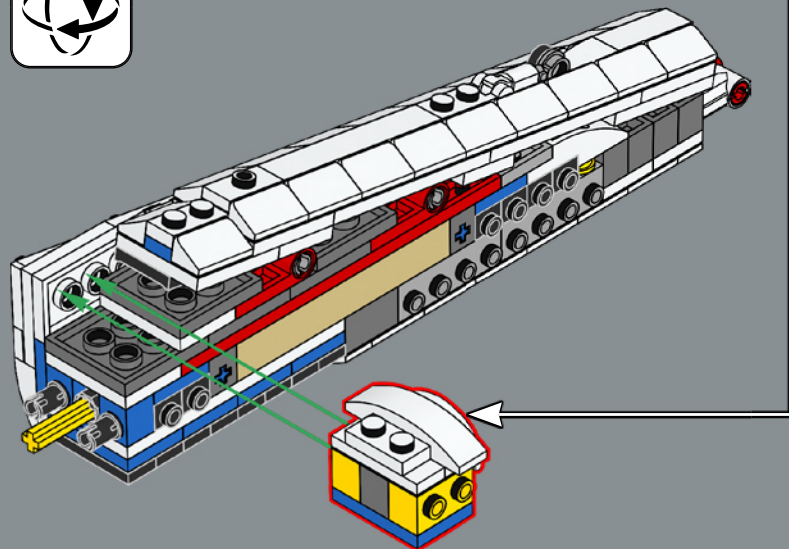
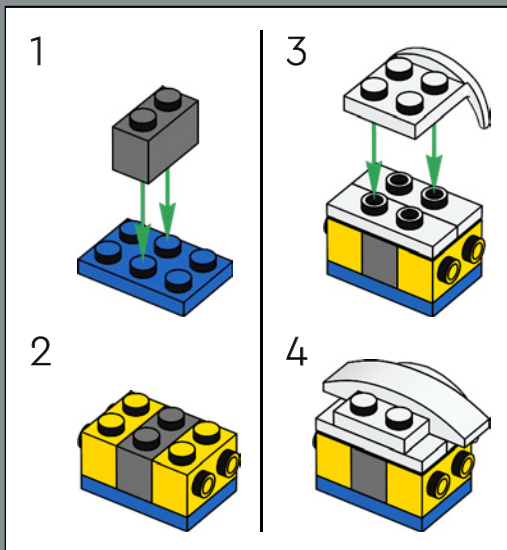

469

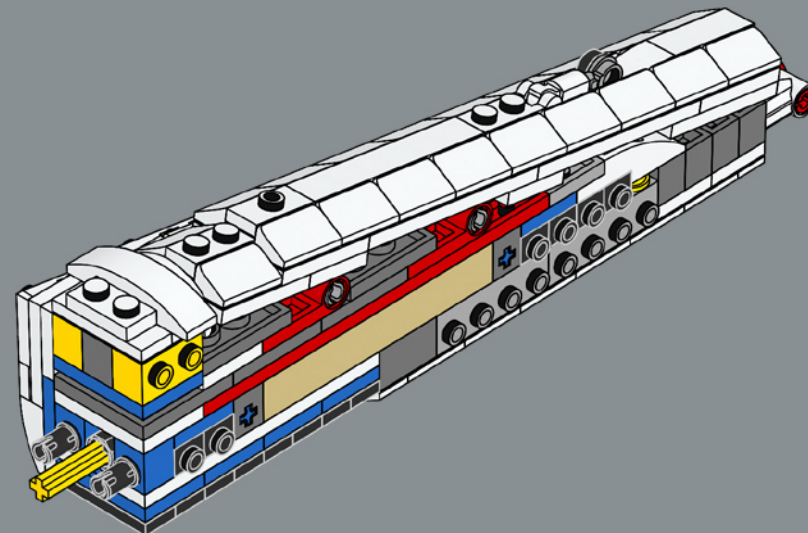

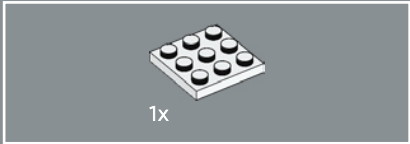
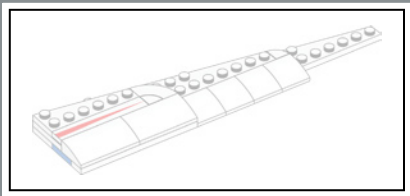

470



471

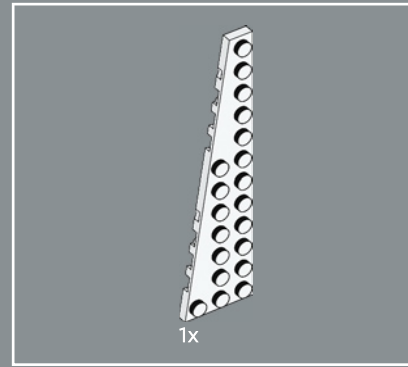

1x

472

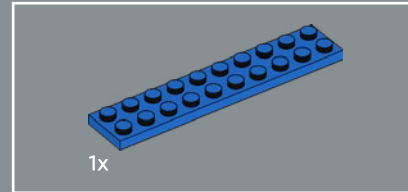
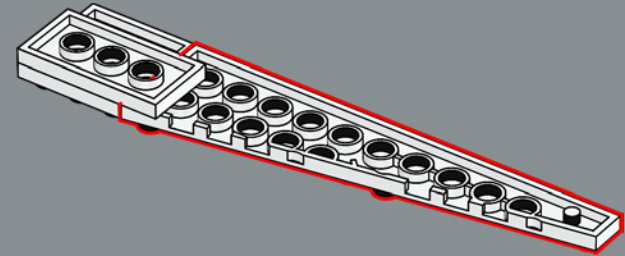

1x

473

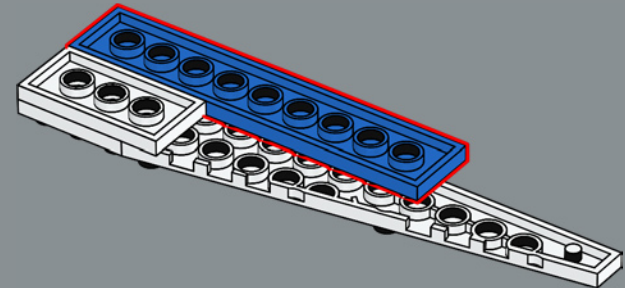

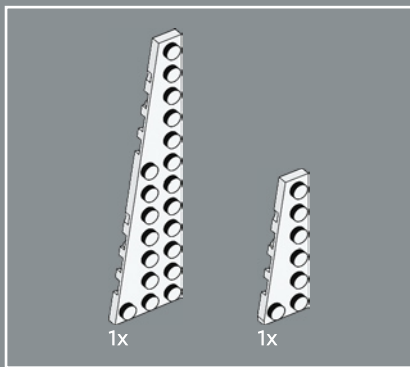

474

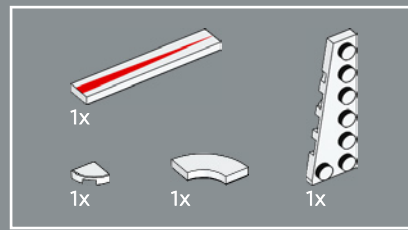
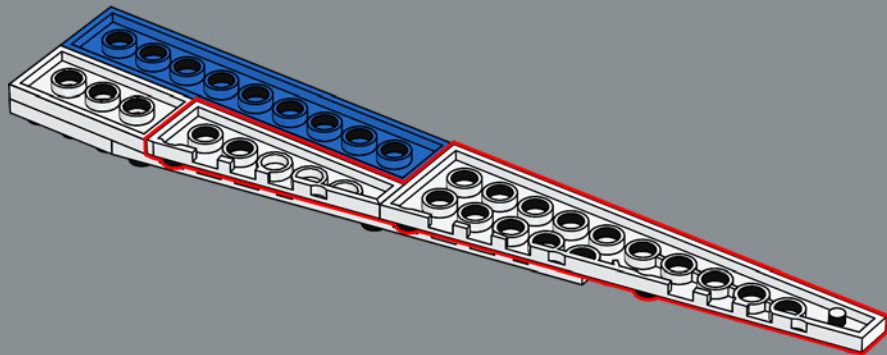

475

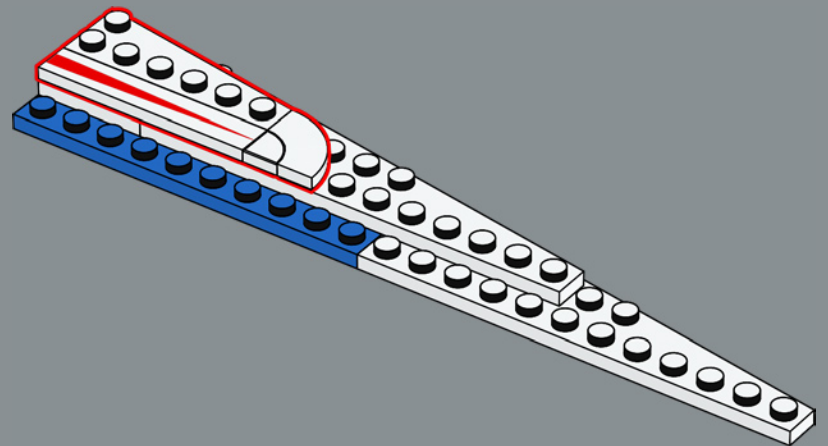

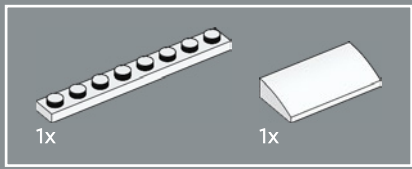

476

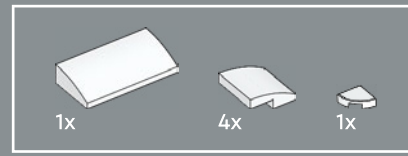
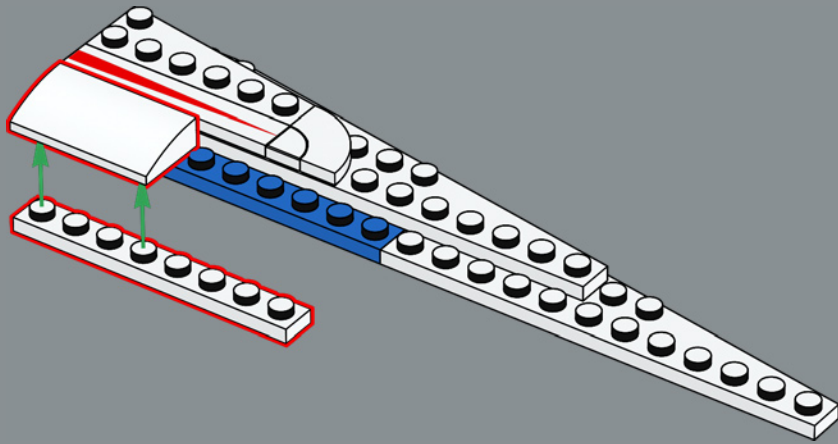

477

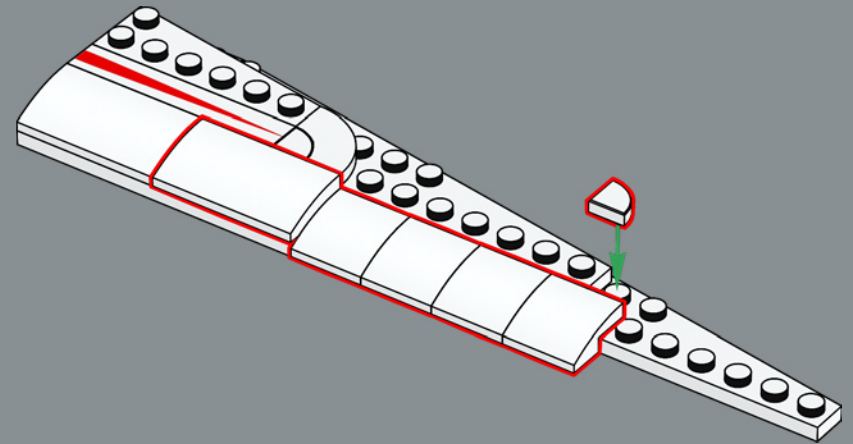

478

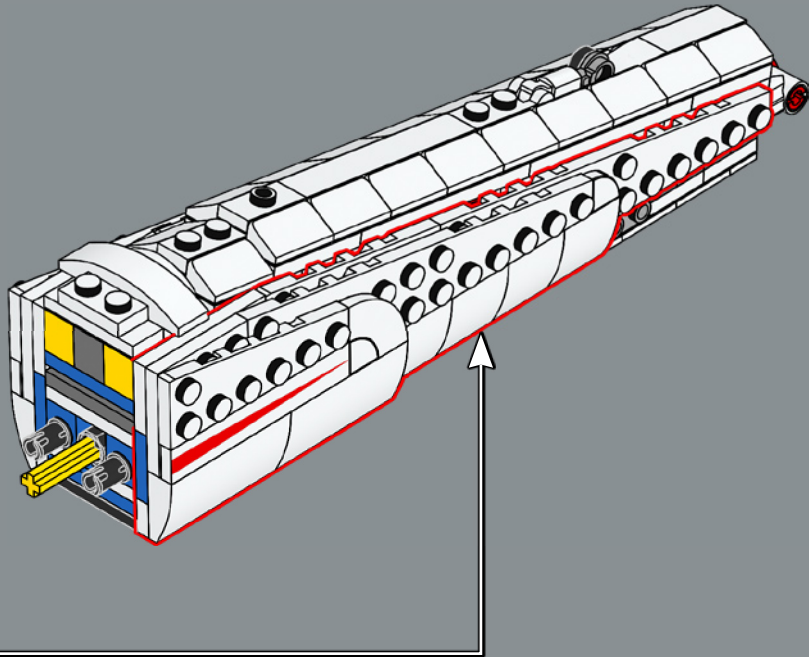

479

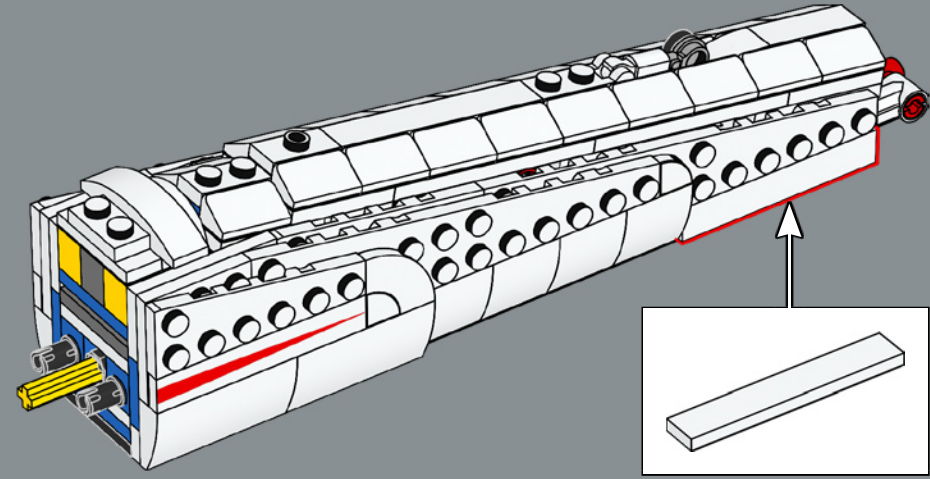
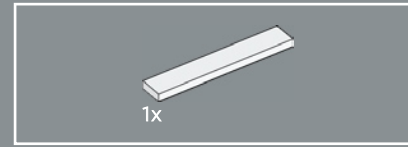

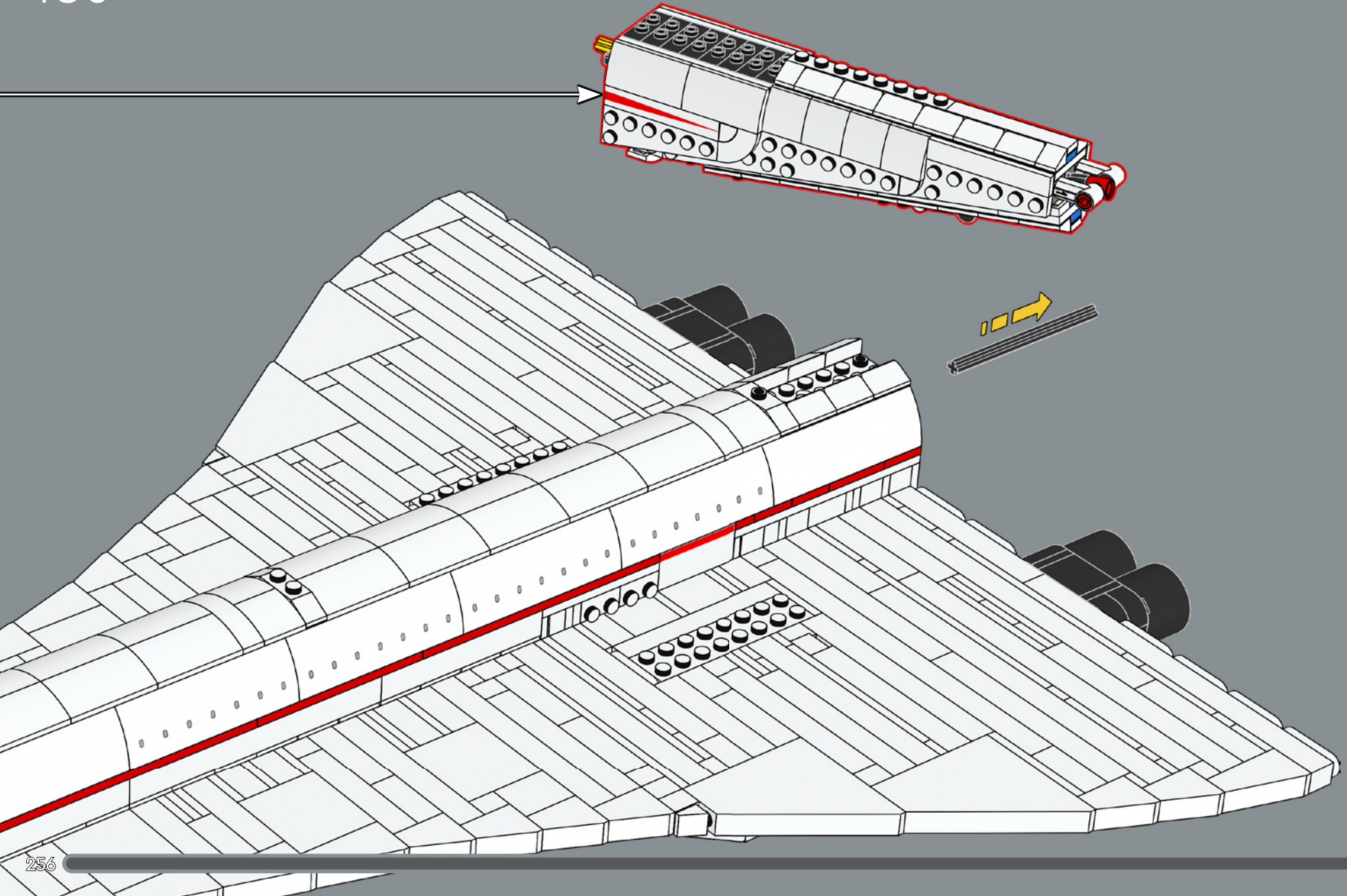

481

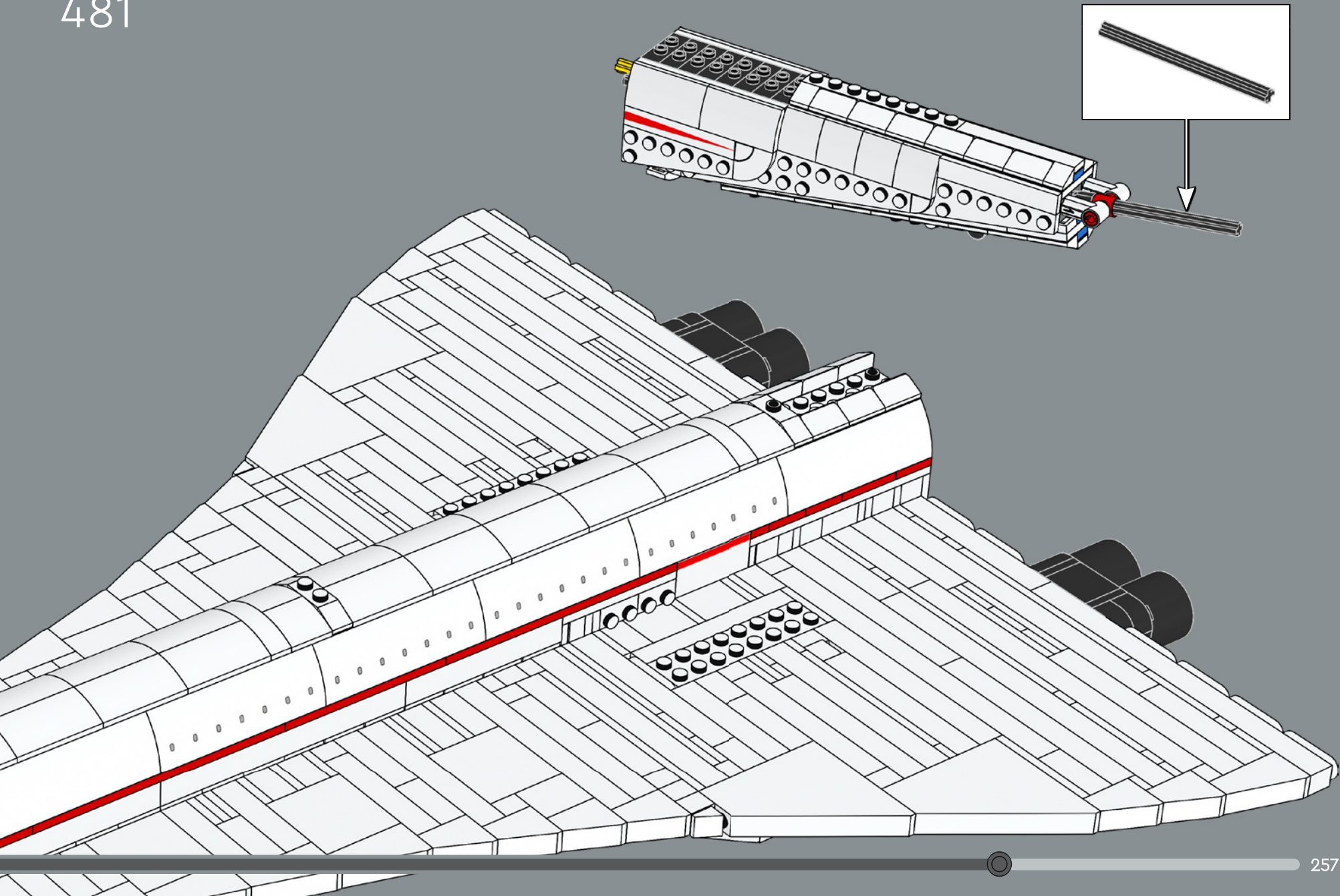

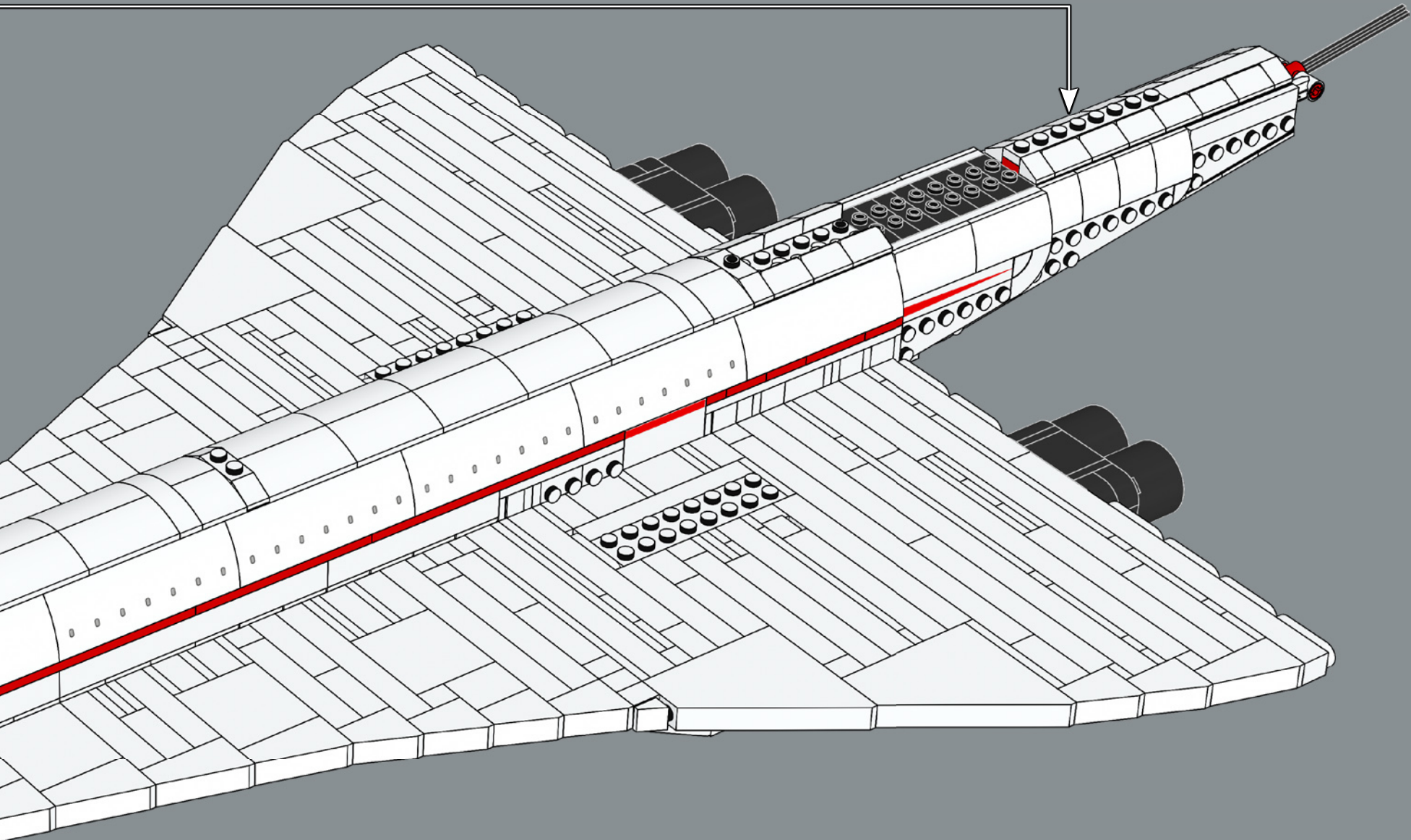

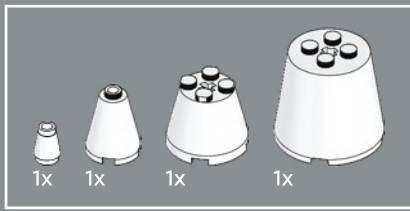

483

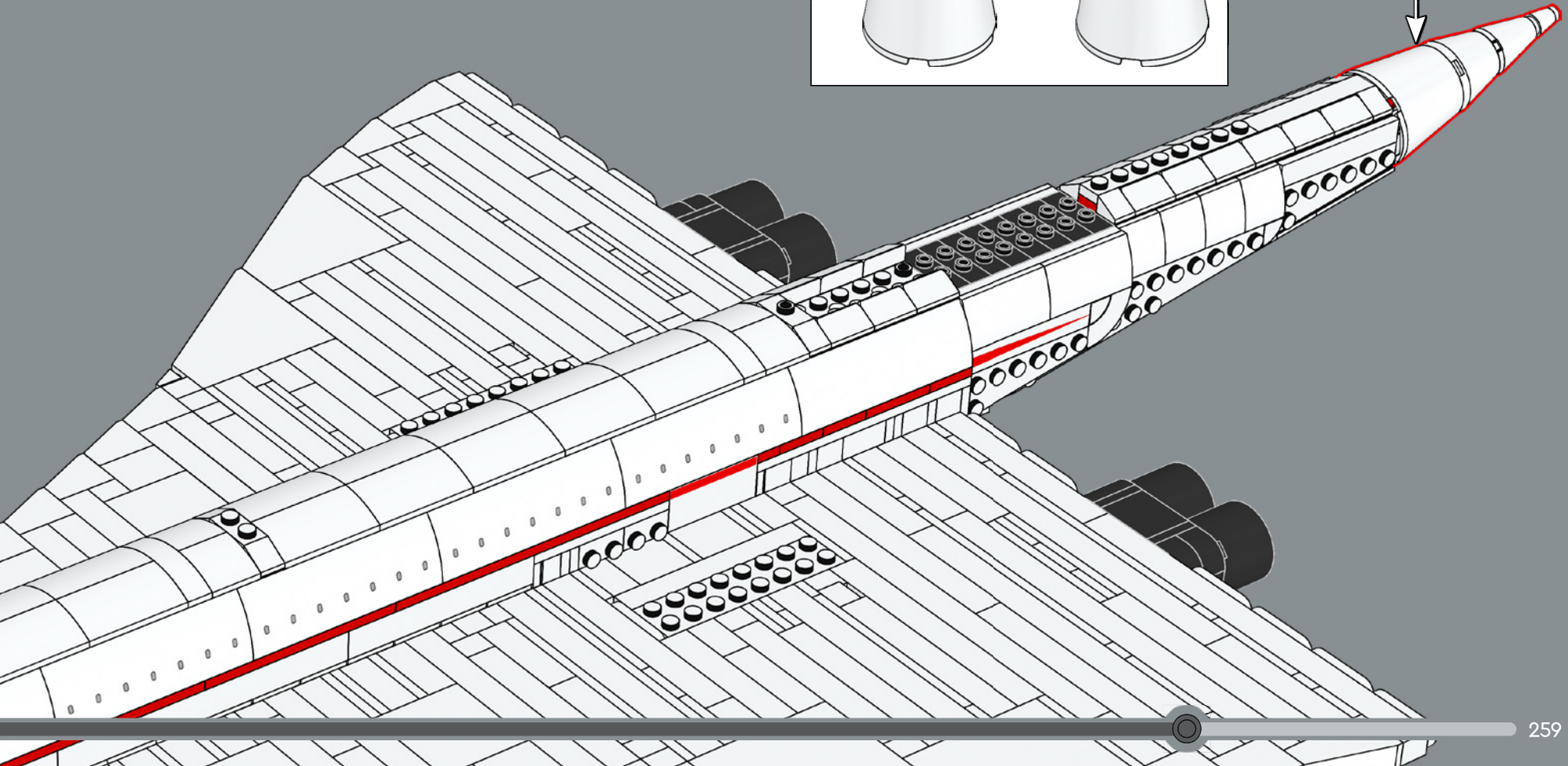
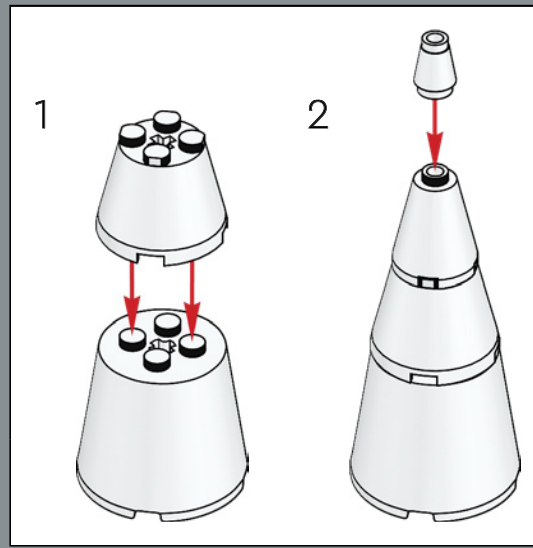

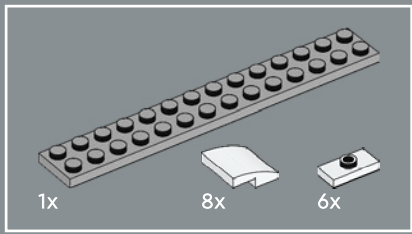

484

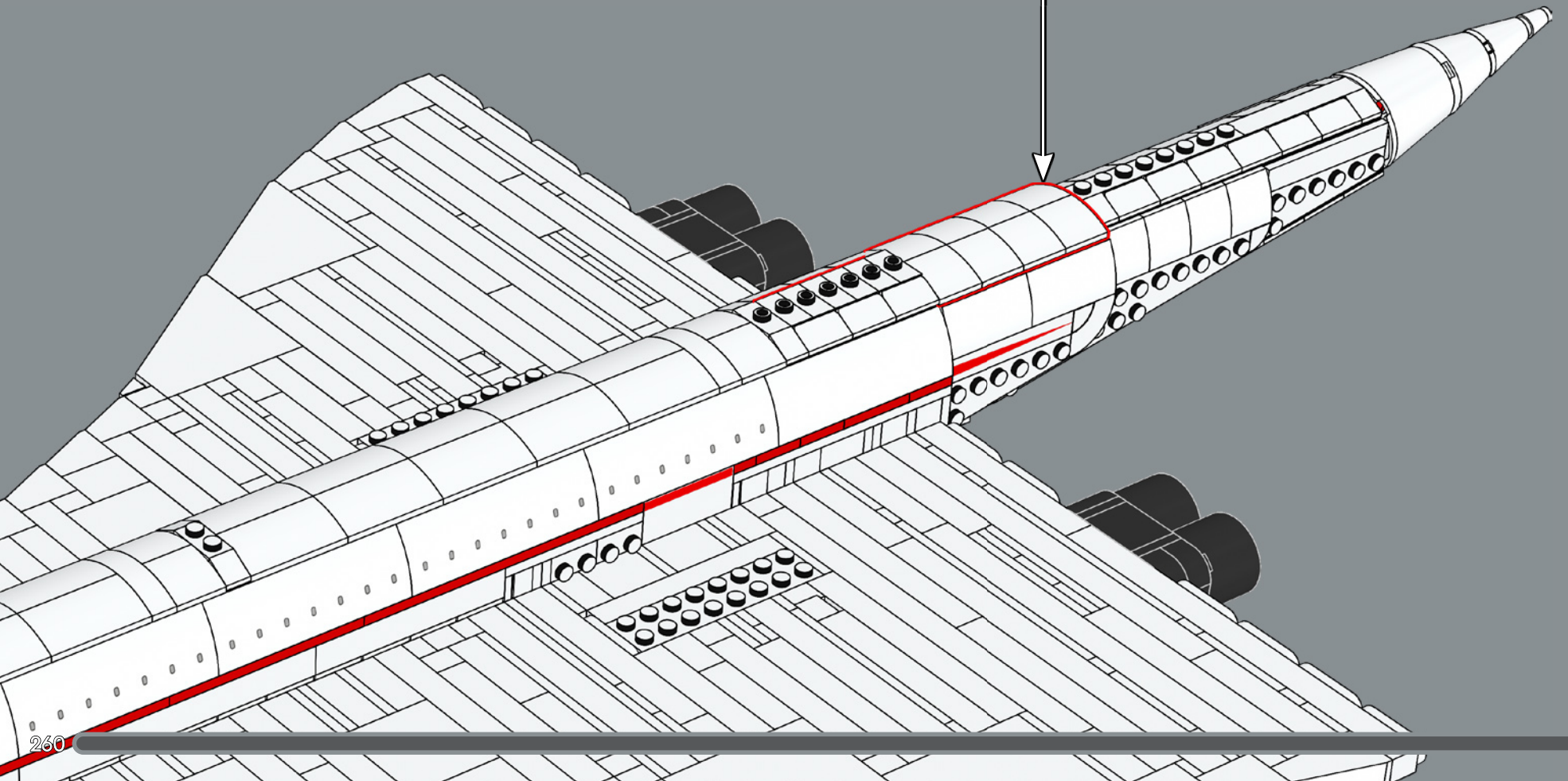
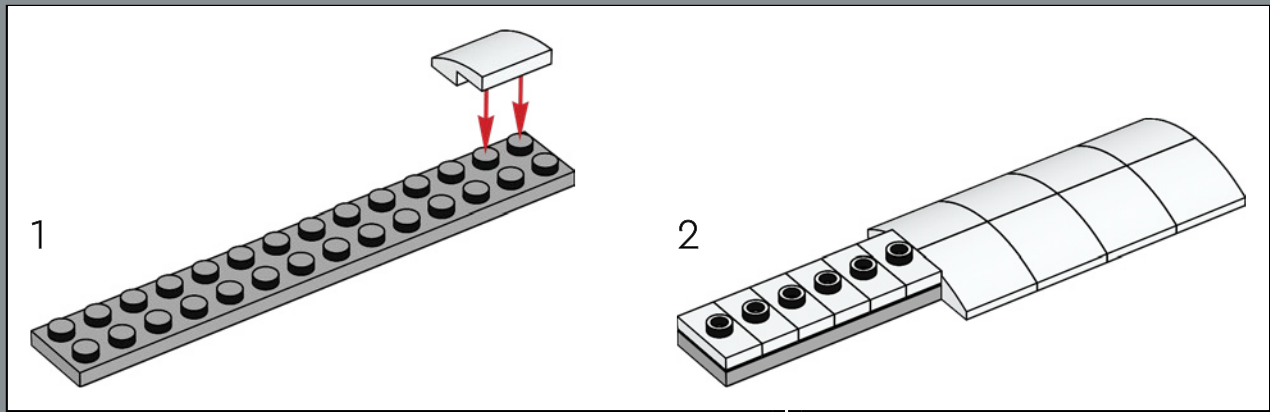



485

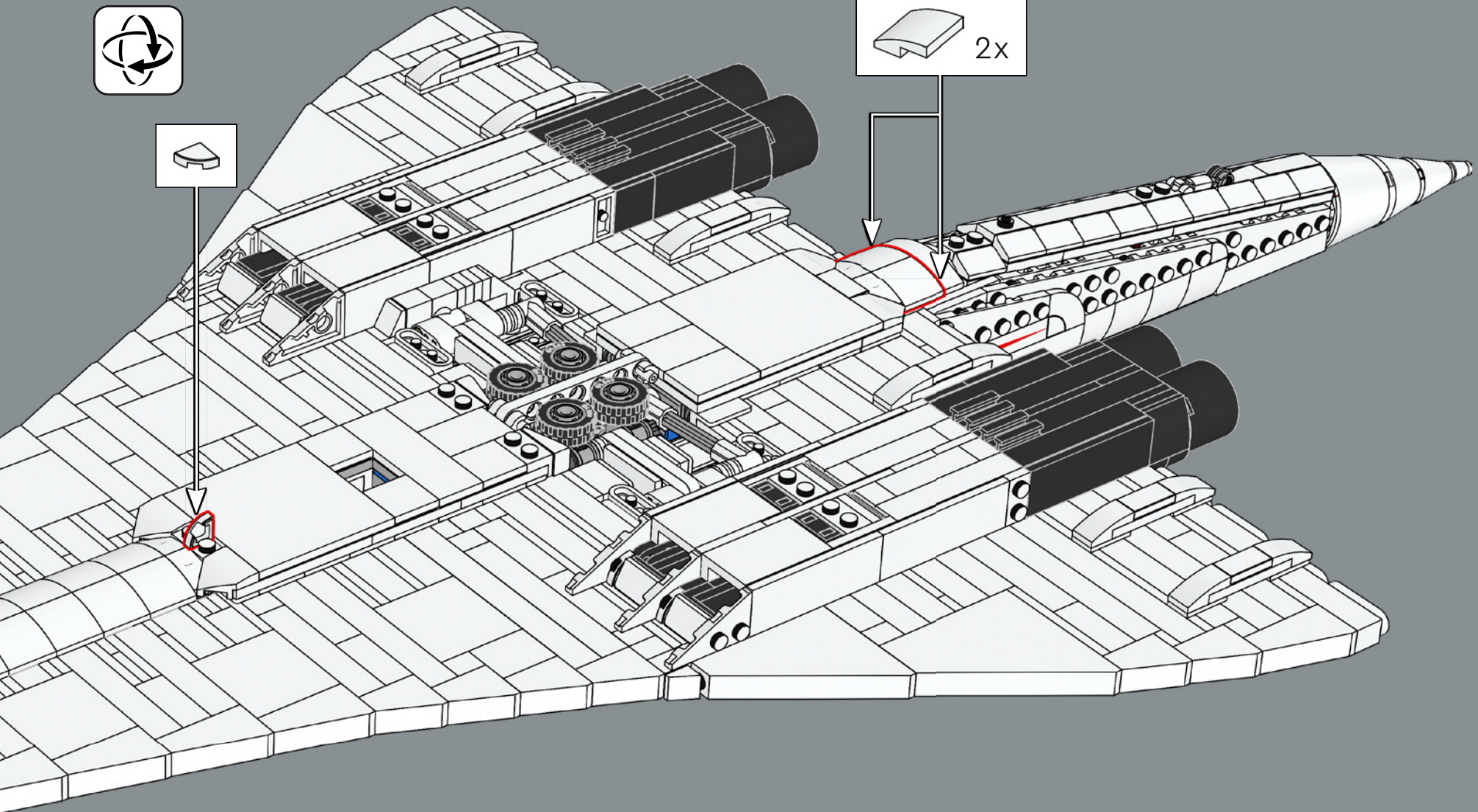

486

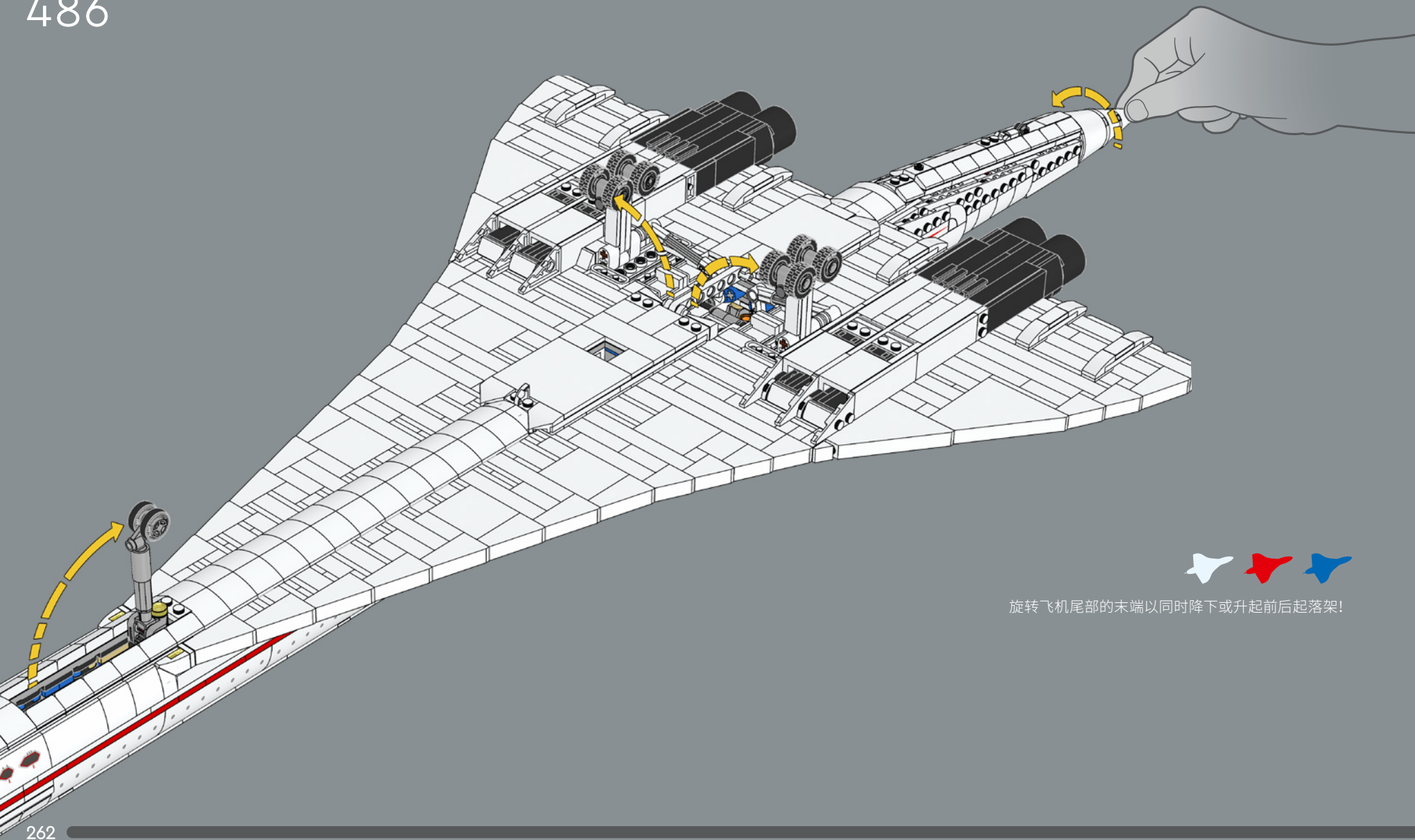

旋转飞机尾部的末端以同时降下或升起前后起落架!



487

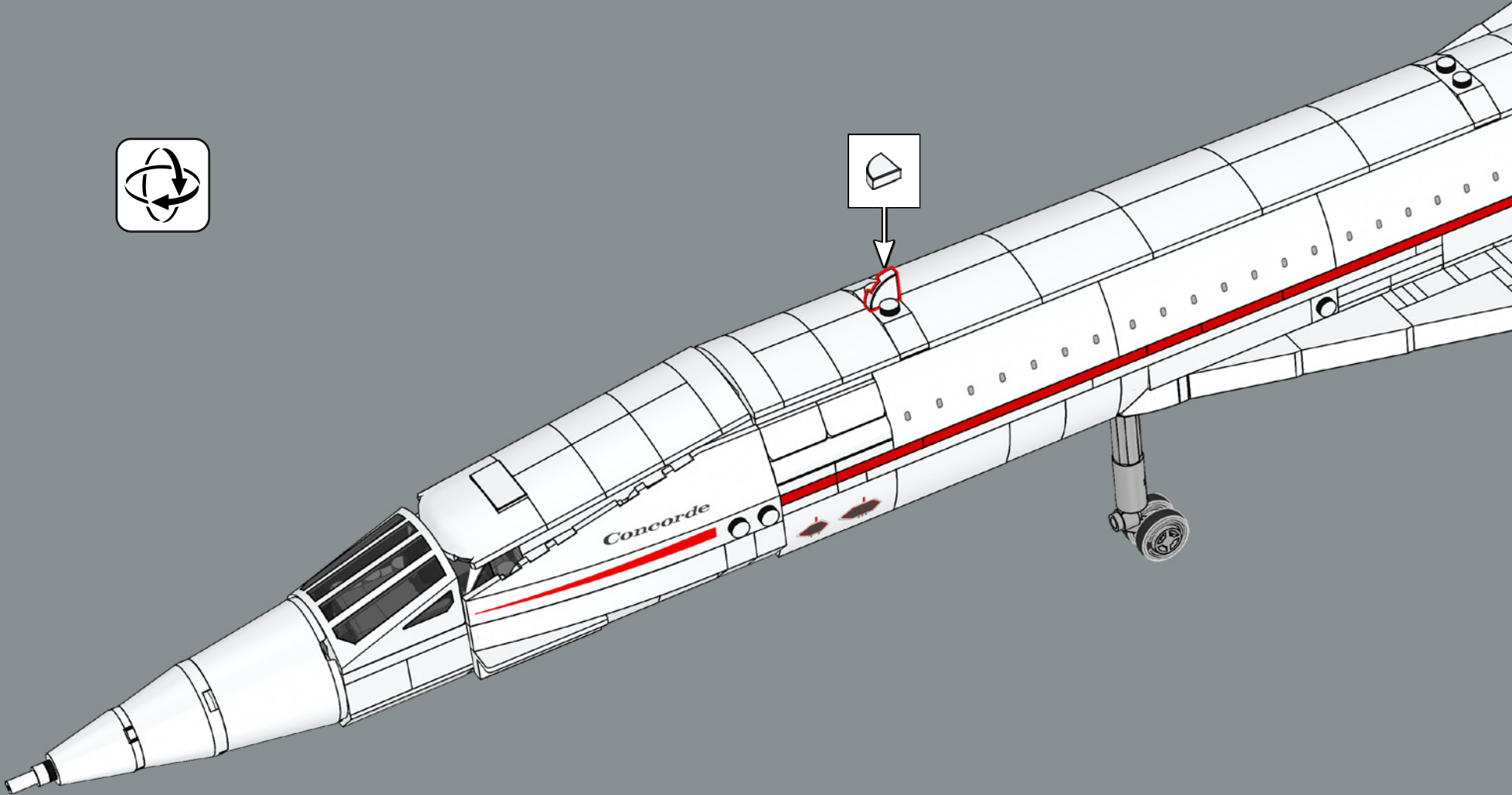



一共建造了二十架协和式飞机，六架开发型飞机和十四架商用飞机。大多数飞机服役了 27 年。

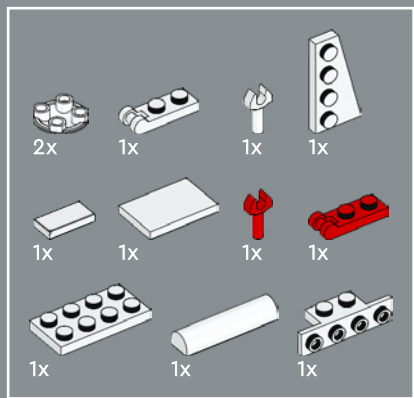

488

1



2

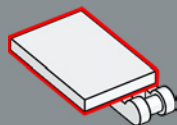

3



4

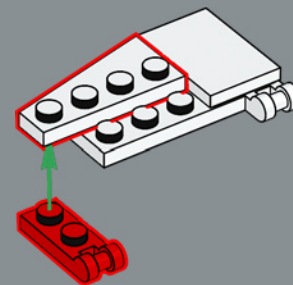

5

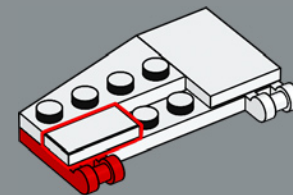

6

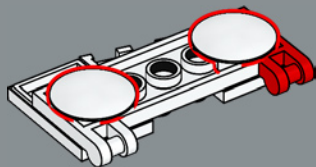

7

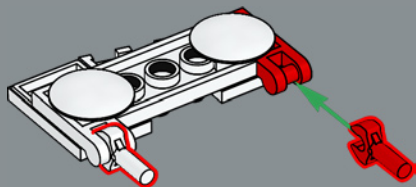

8

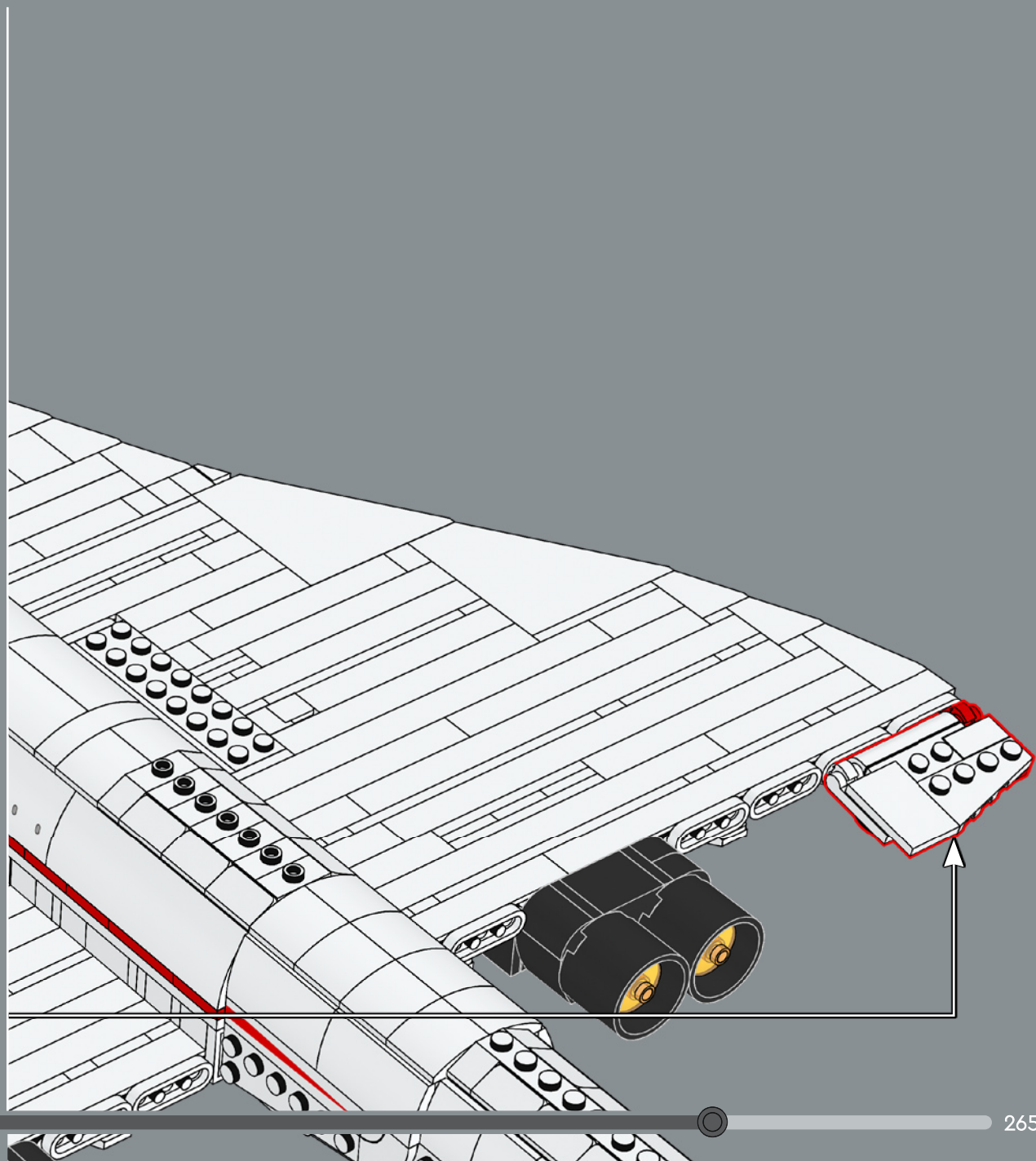
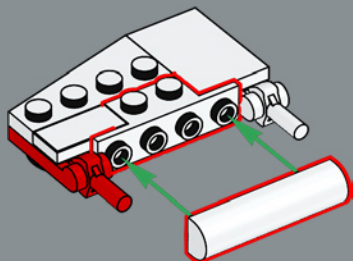

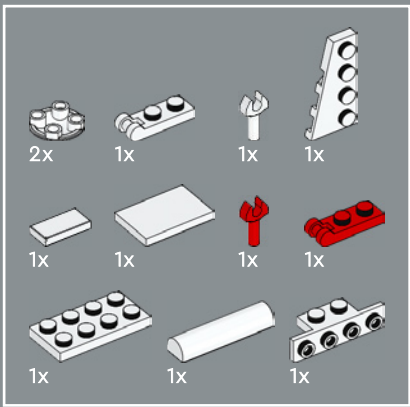

489

1



2

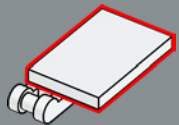

3

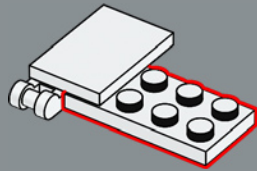

4

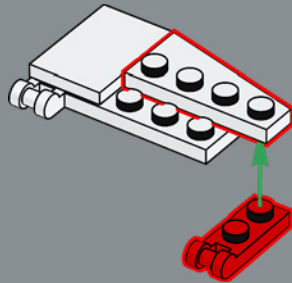

5

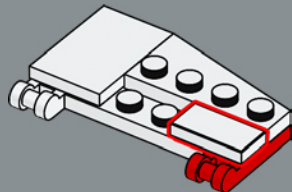

6

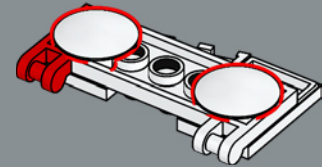

7

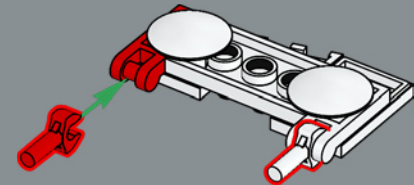

8

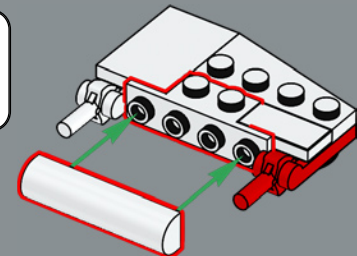

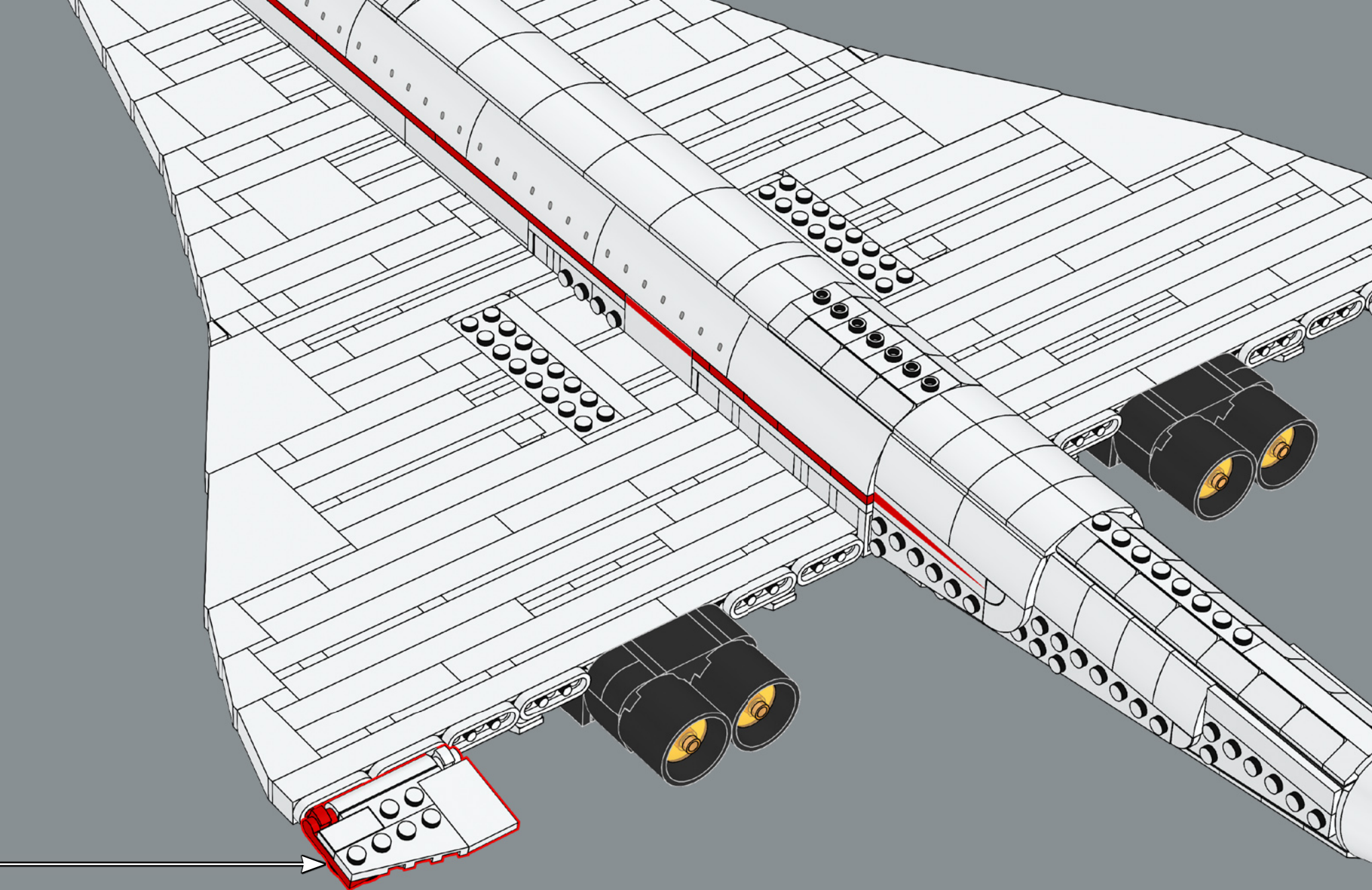

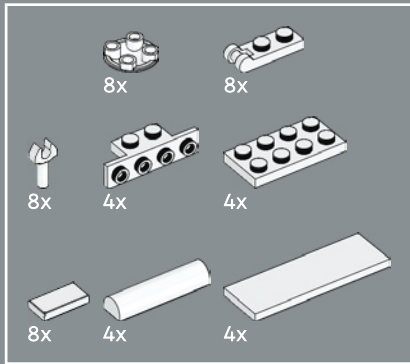
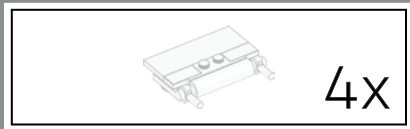

490

1



2

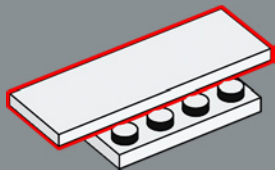

3

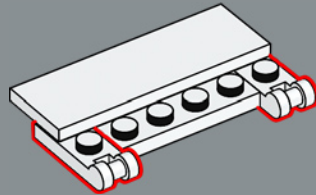

4

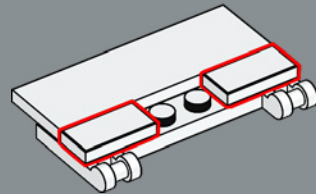

5

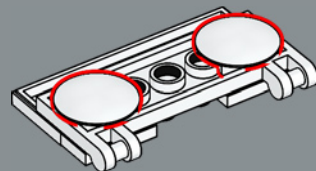

6

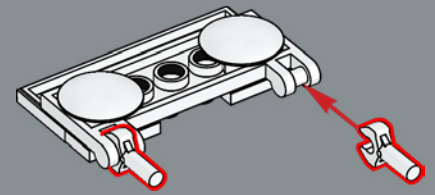

7

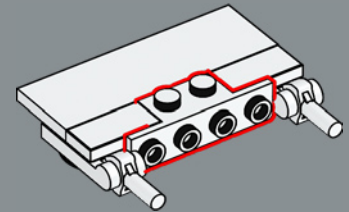

8

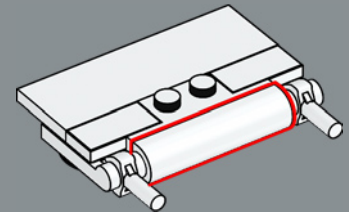

4x

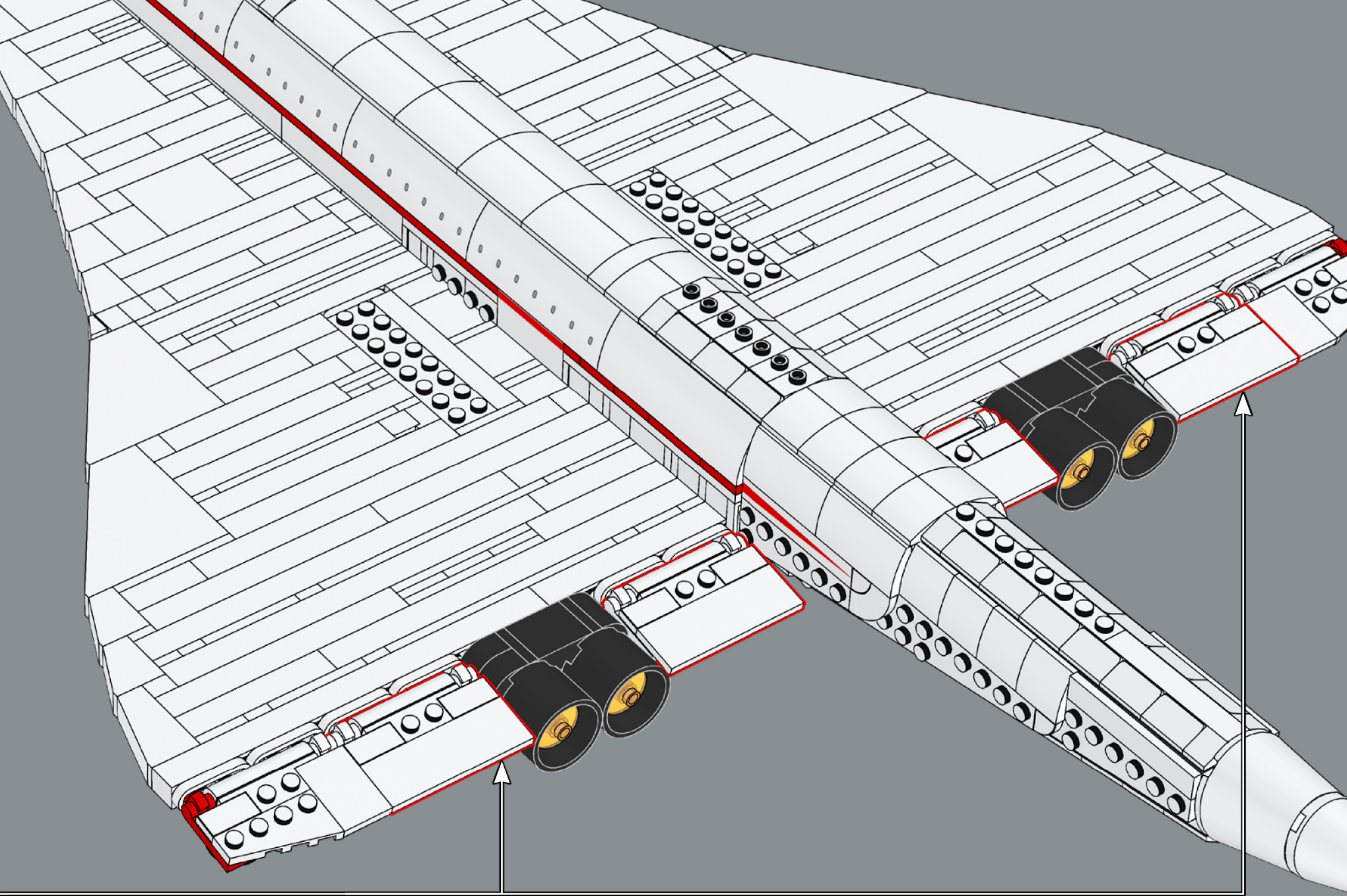

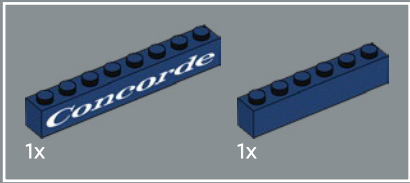
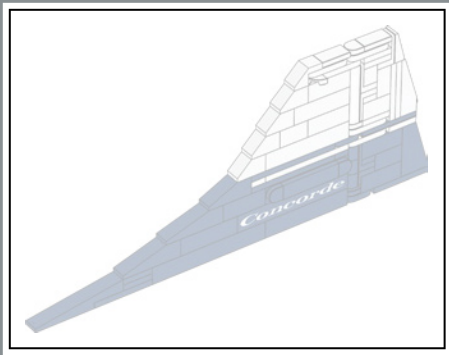

491

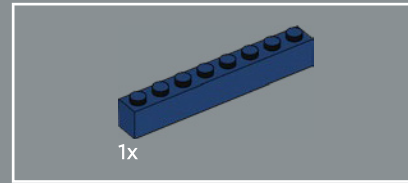
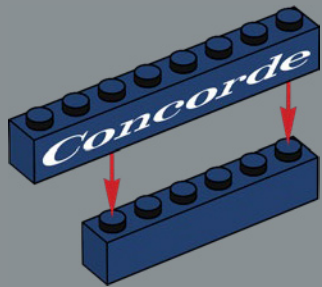

492

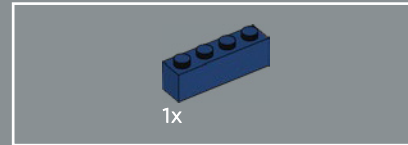
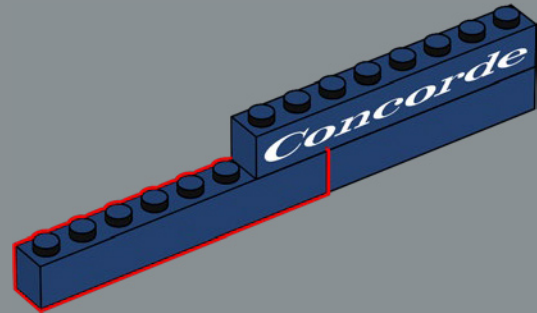

493

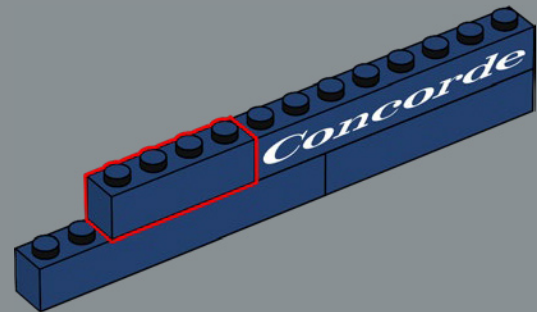

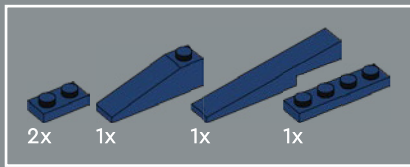

494

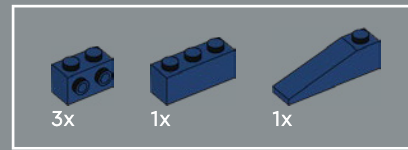
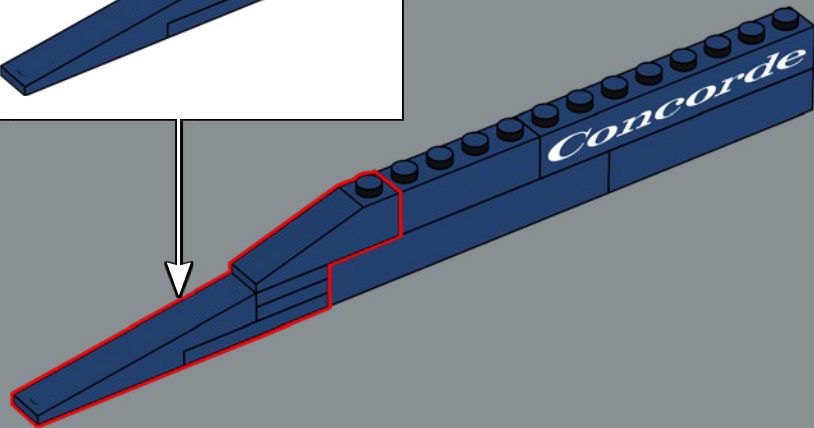
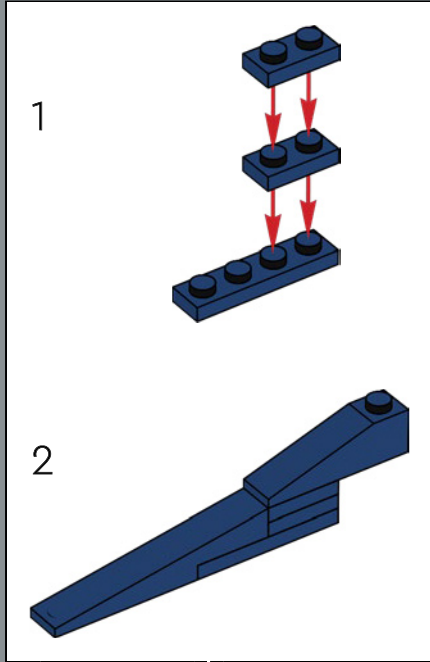

495

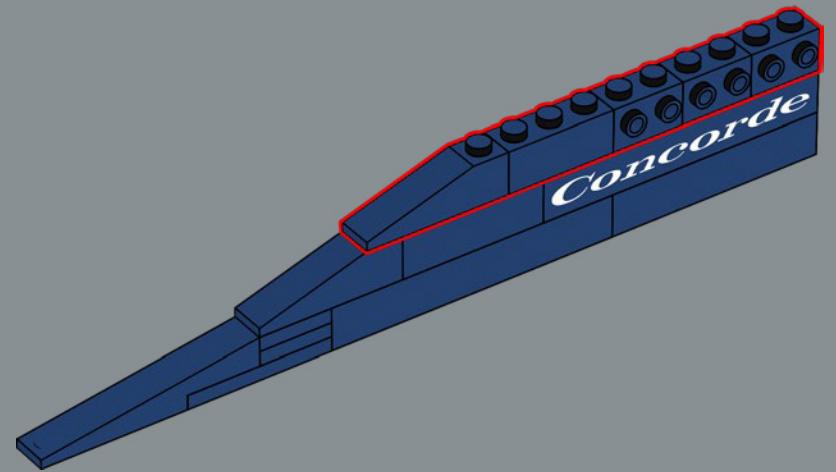

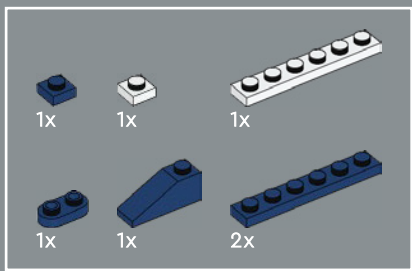

496

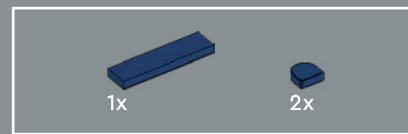
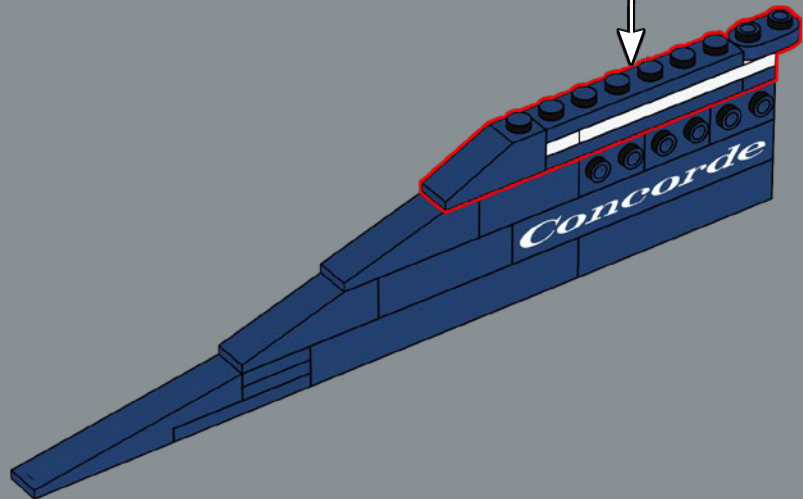
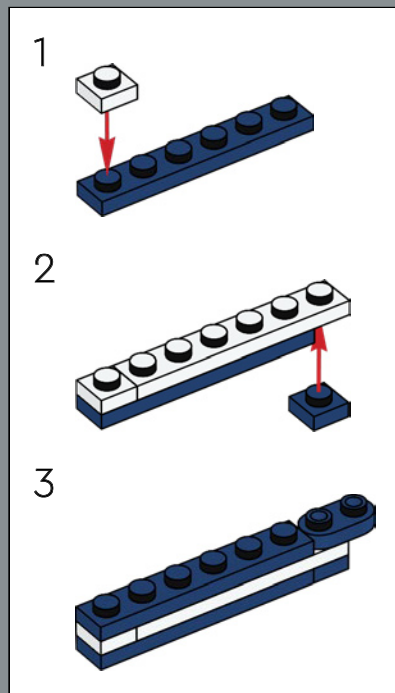

497

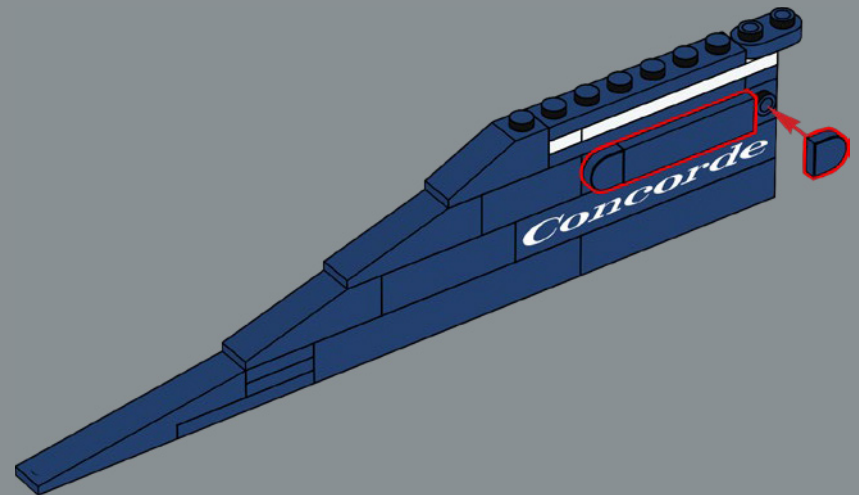

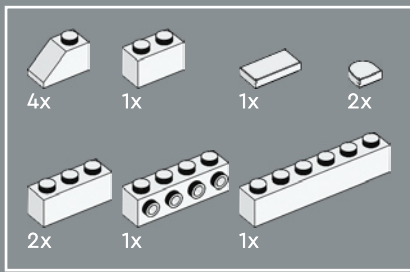

498

1

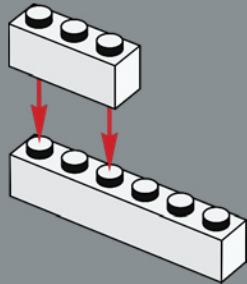

2

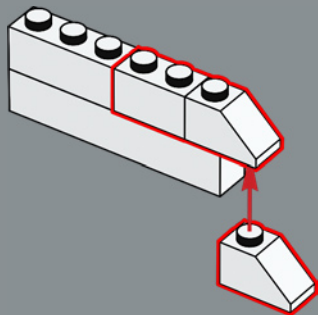

3

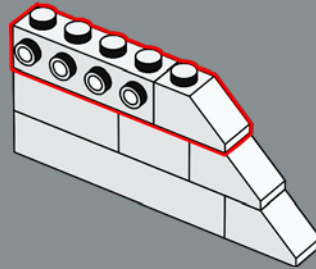

4

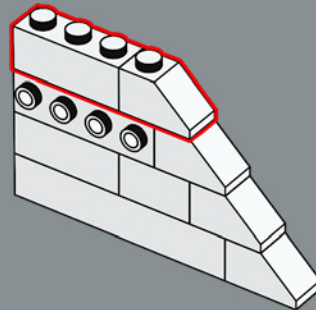

5

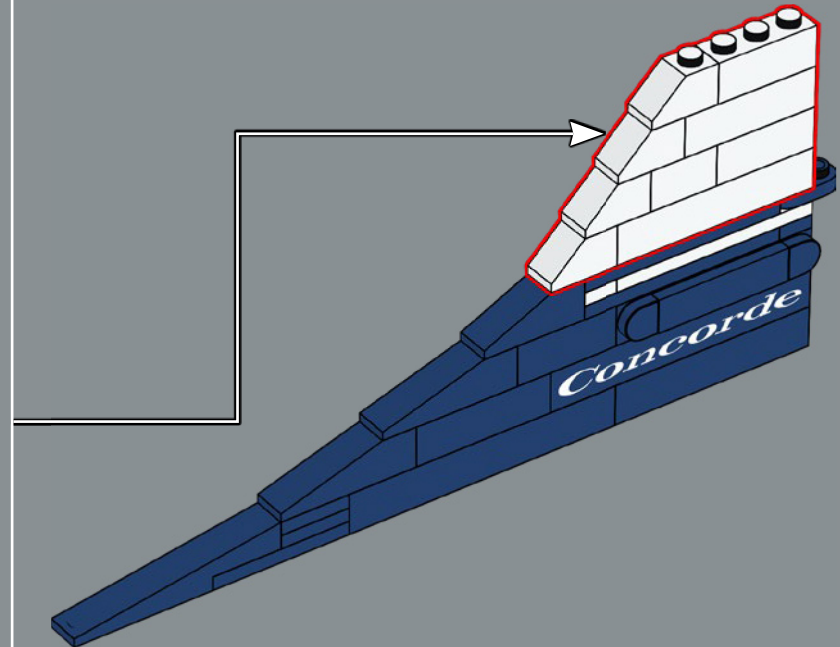
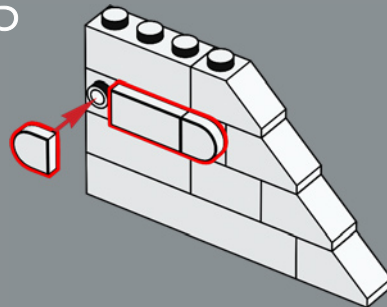

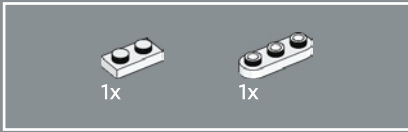
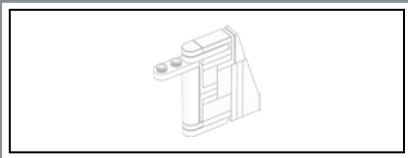

499

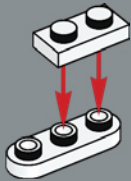

500

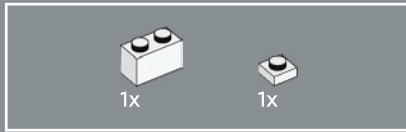

501

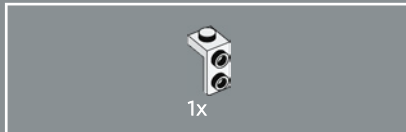
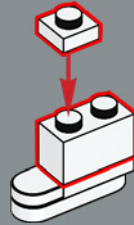

502

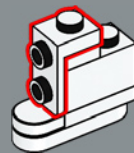

503

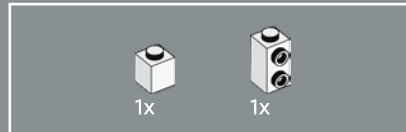
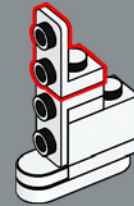

504

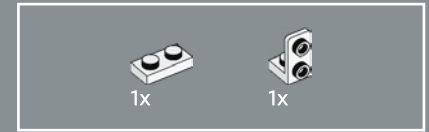
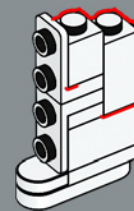

505

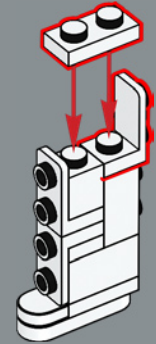

506

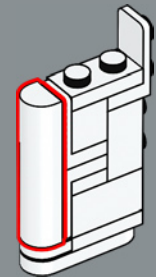

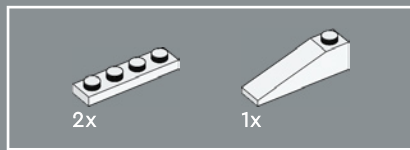

507

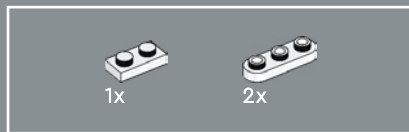
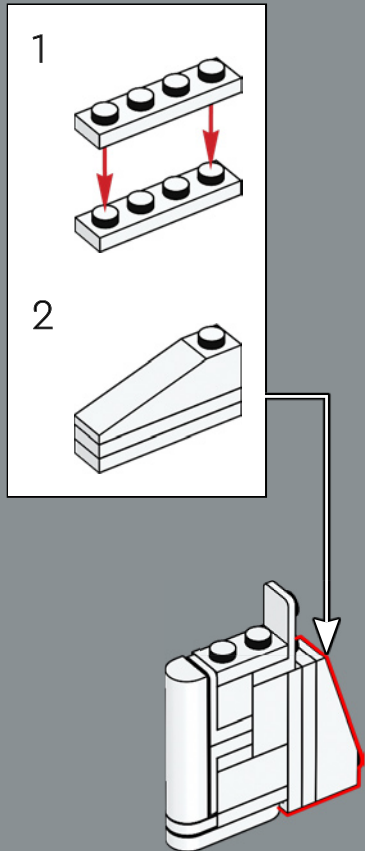

508

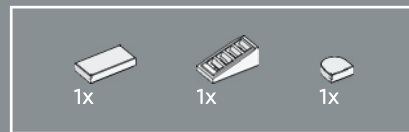
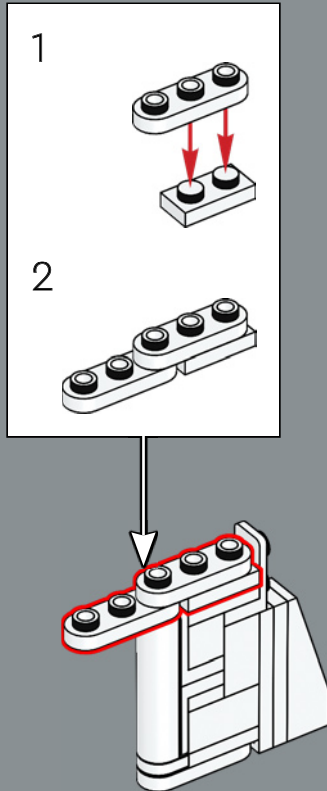

509

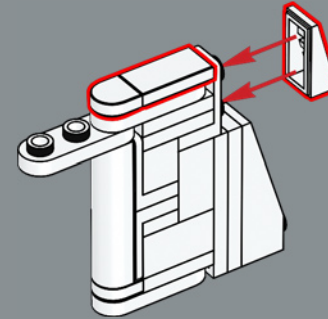

510

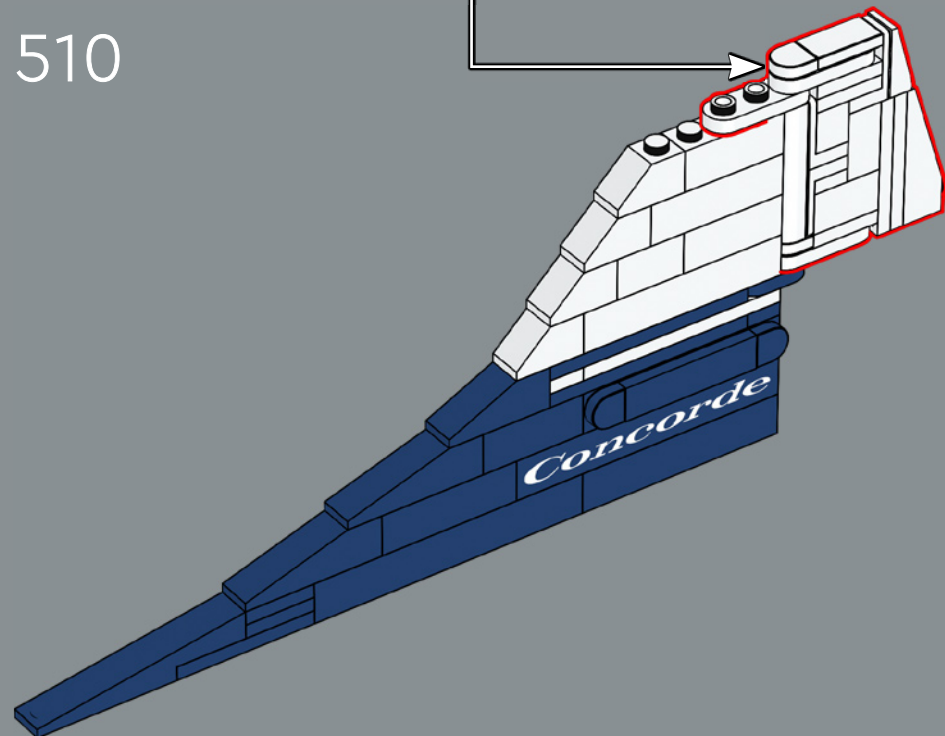

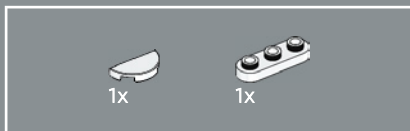

511

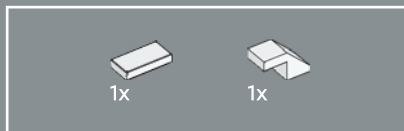
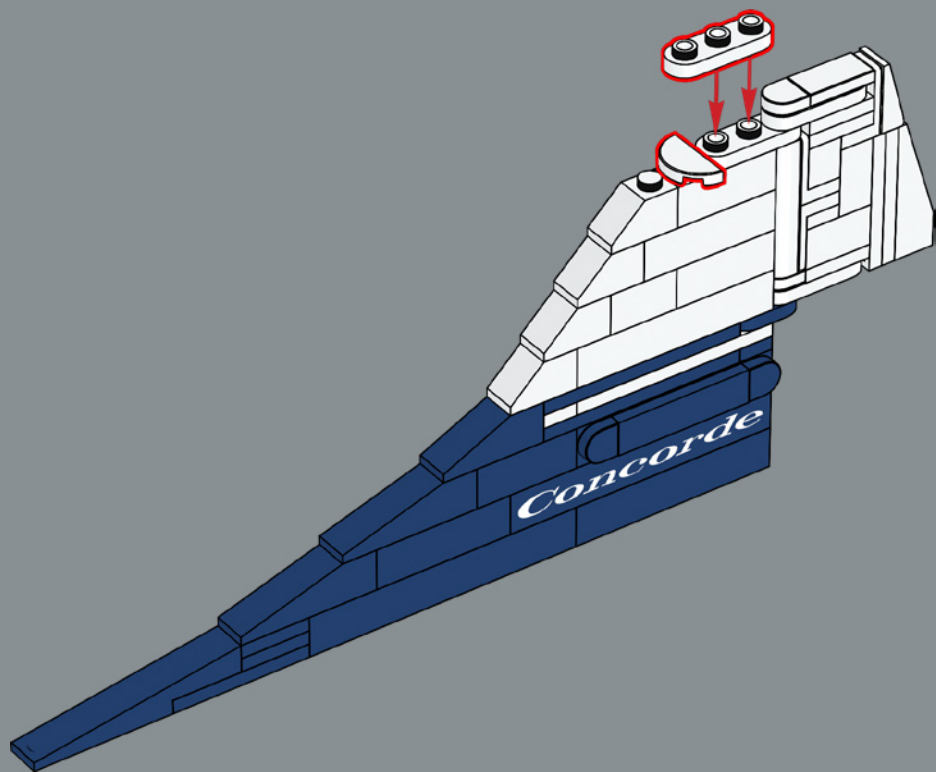

512



协和式飞机采用分体式方向舵，其下段仅在高速下使用，以便进行更精细的调整并减少垂直安定面的扭转。

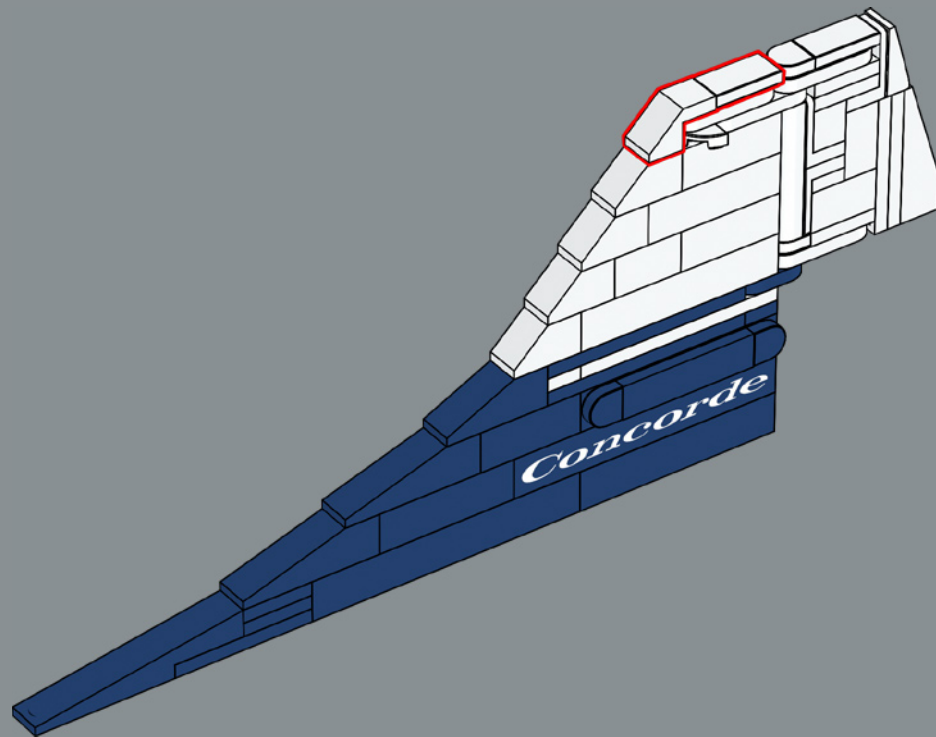

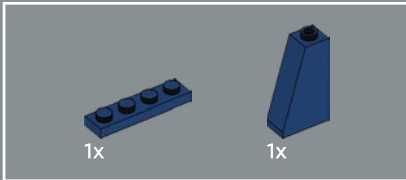
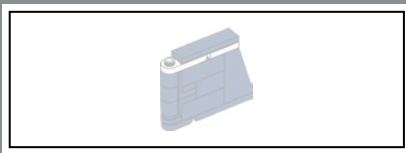

513

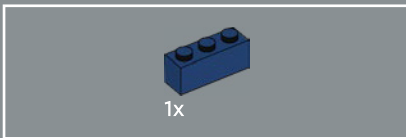
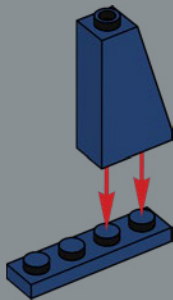

514

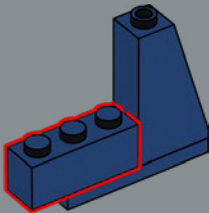

515

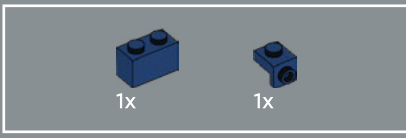
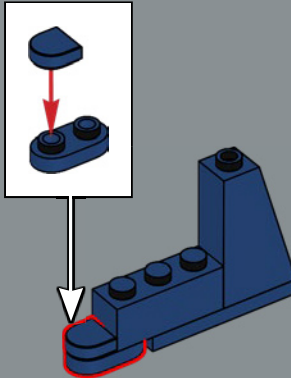

516

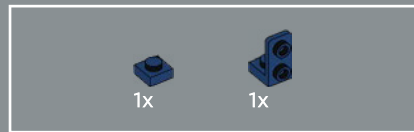
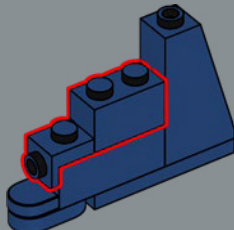

517

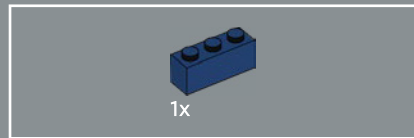
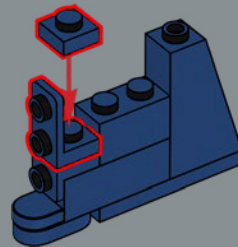

518

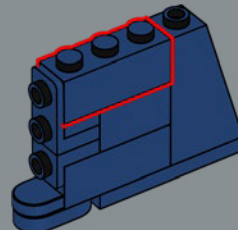

3x

519

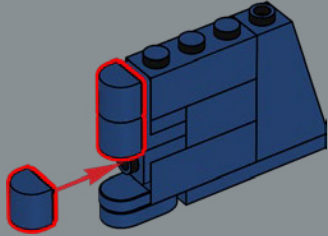

1x

1x

520

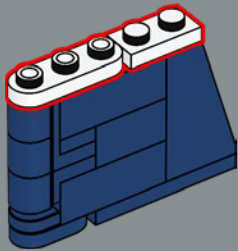

1x

521

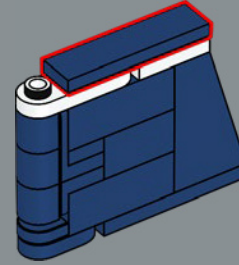

522

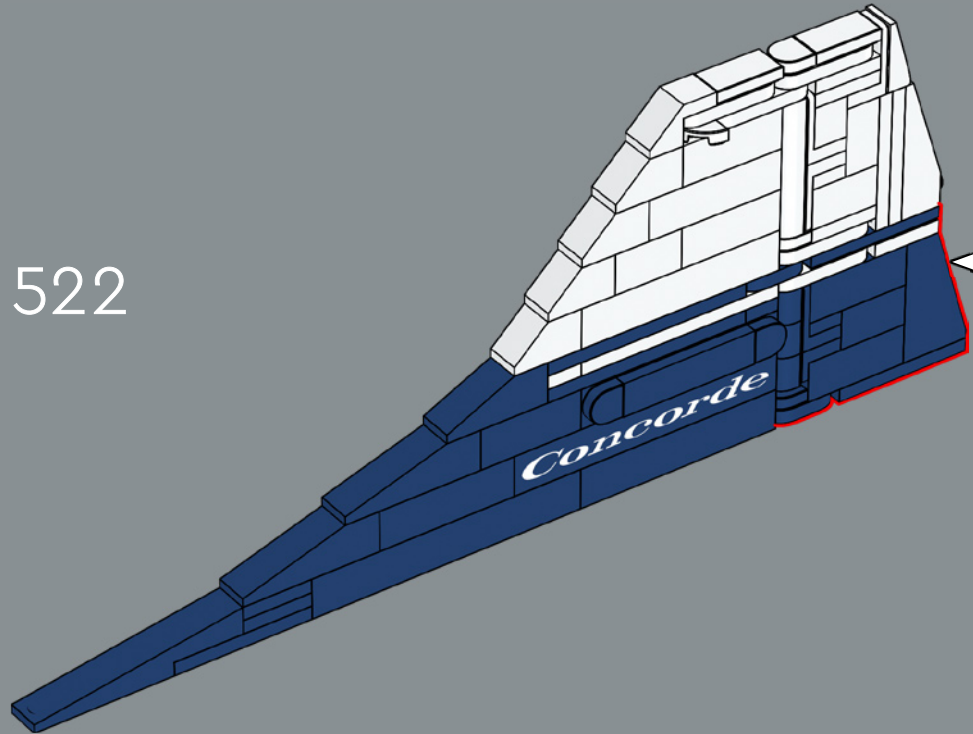

523

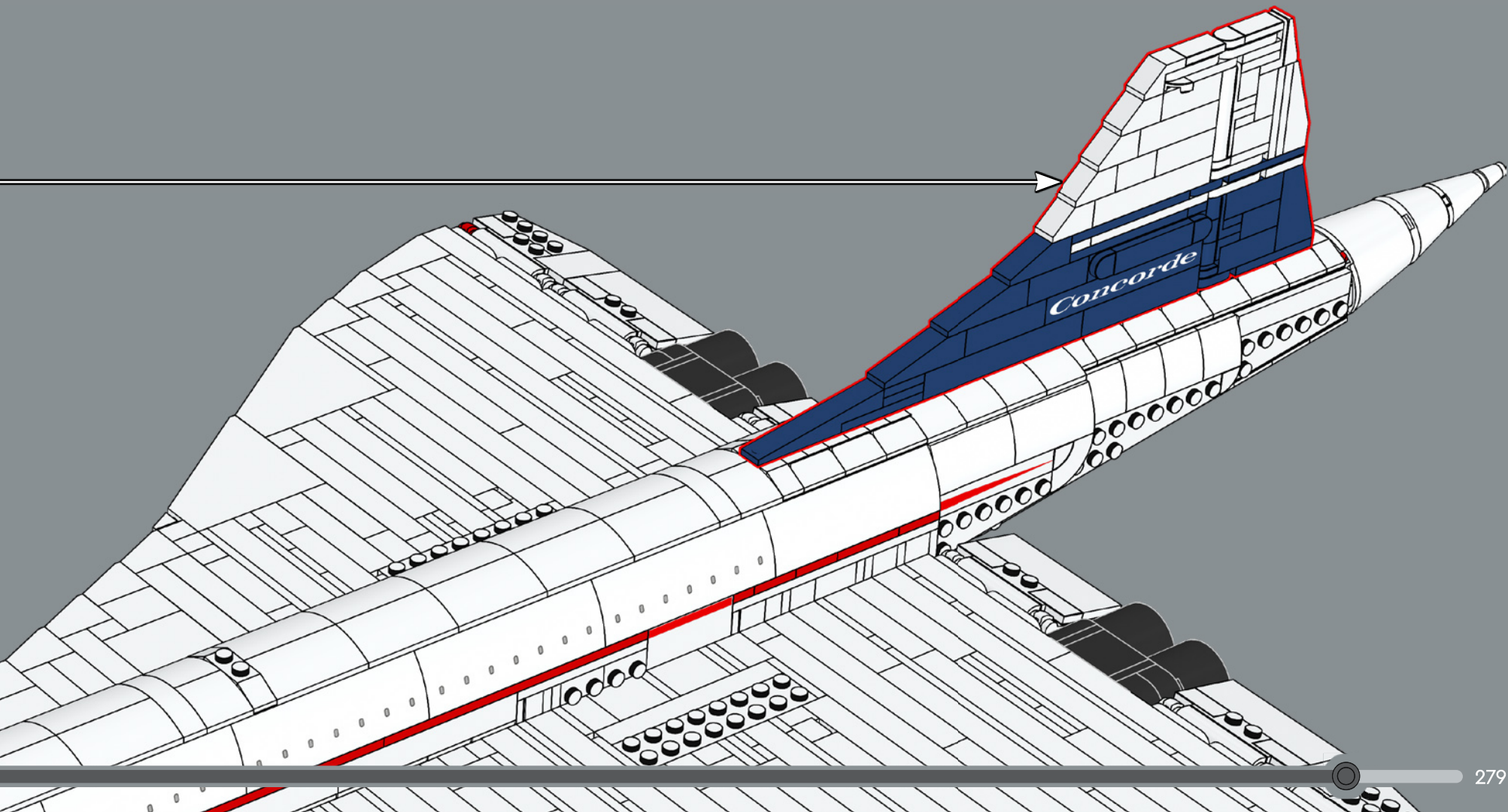

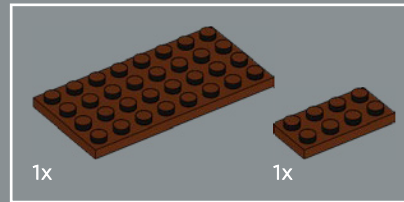
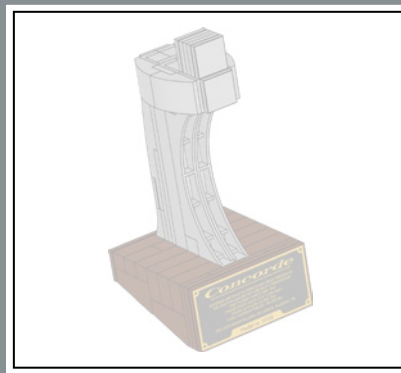

524

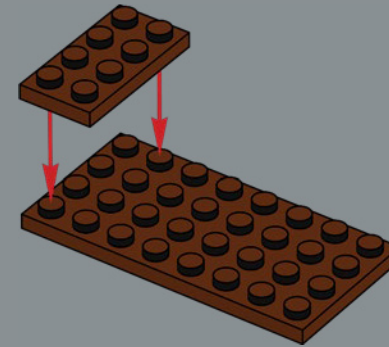

525

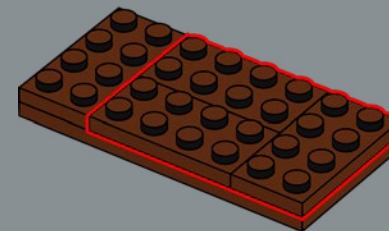

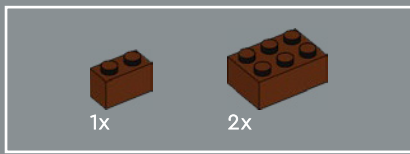

526

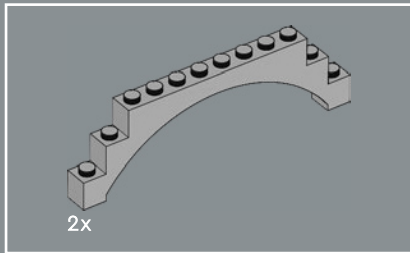
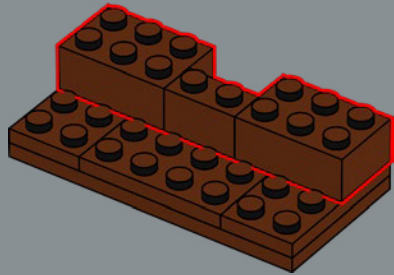

527

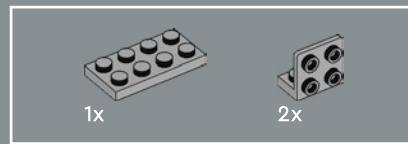
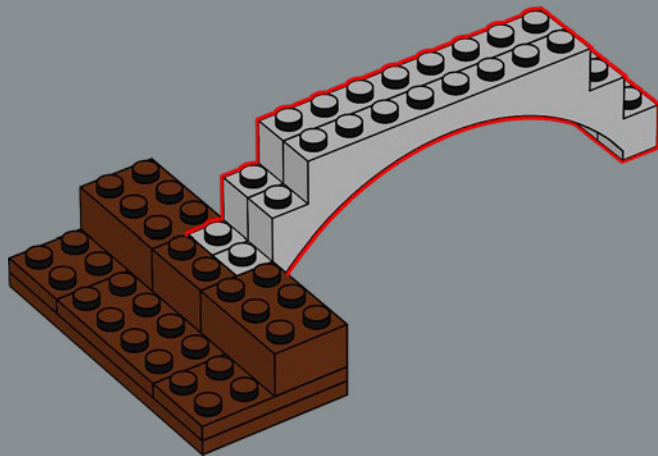

528

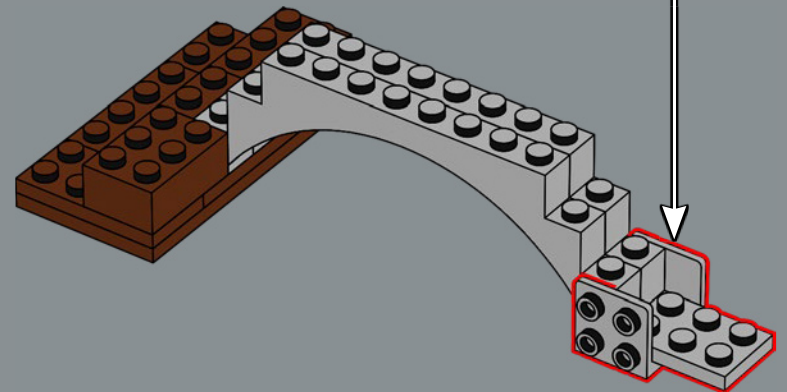
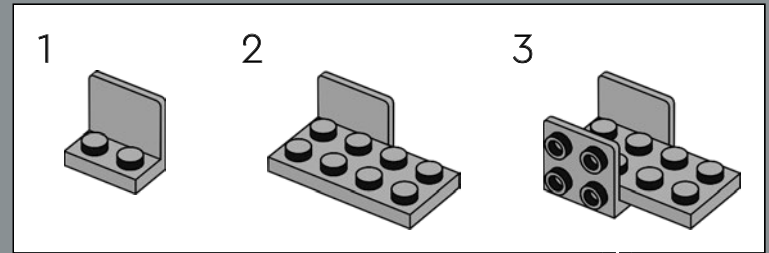

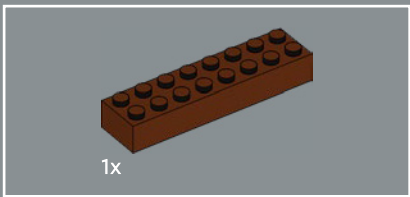

529

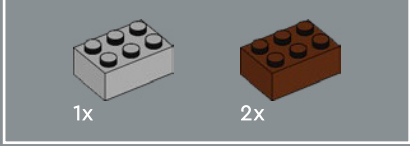
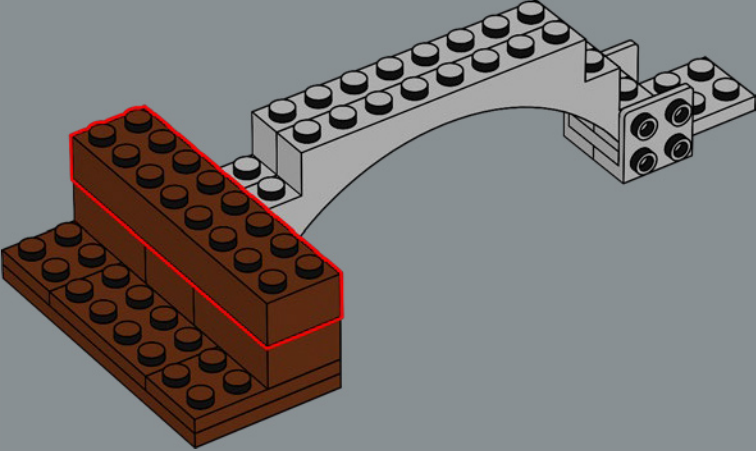

530

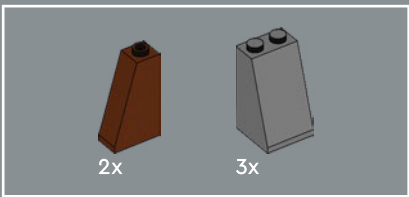
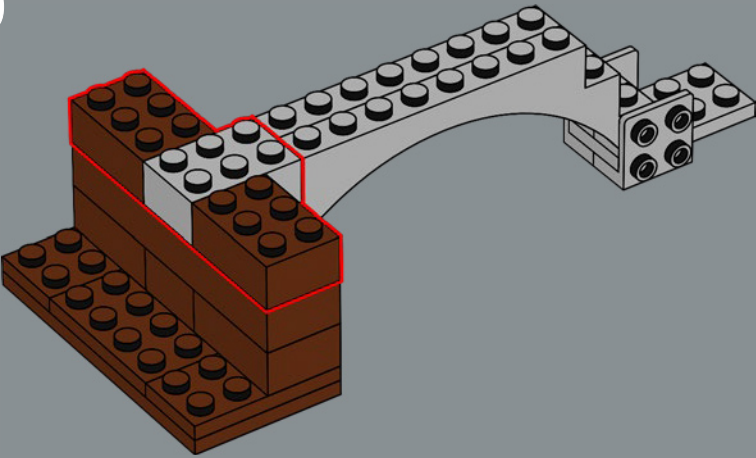

531

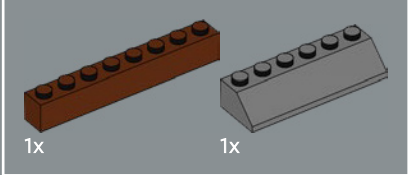
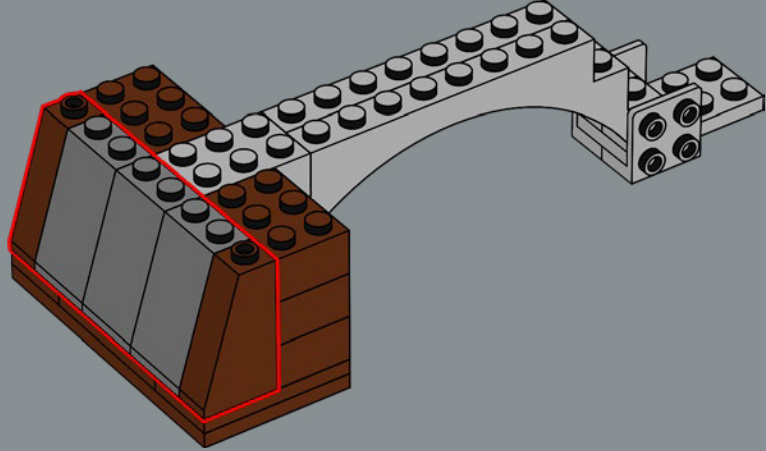

532

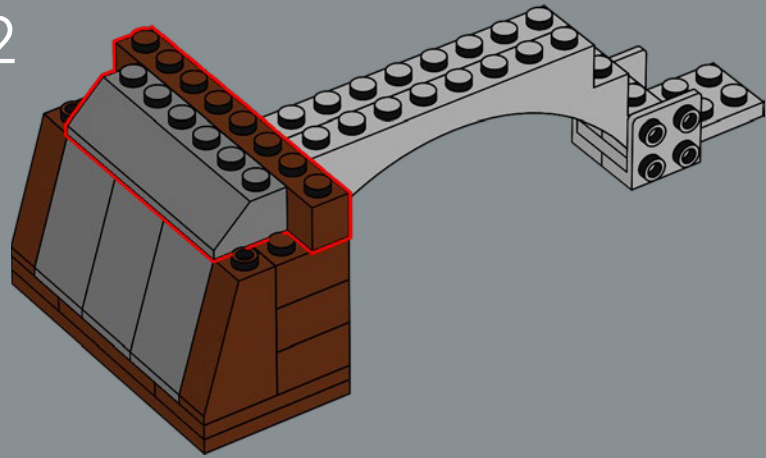

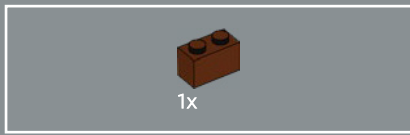

533

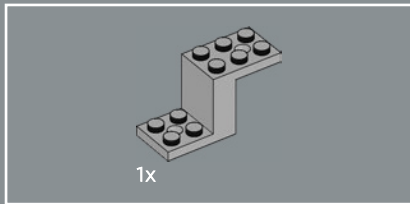
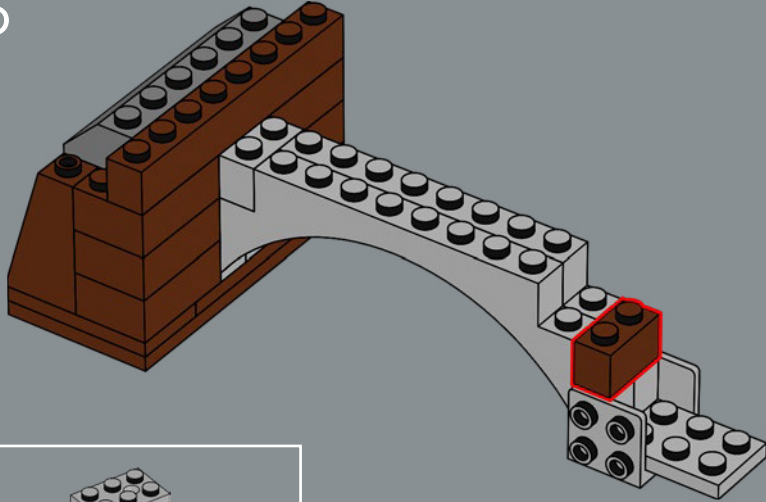

534

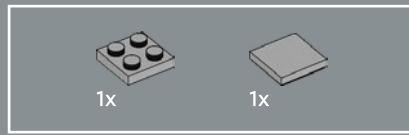
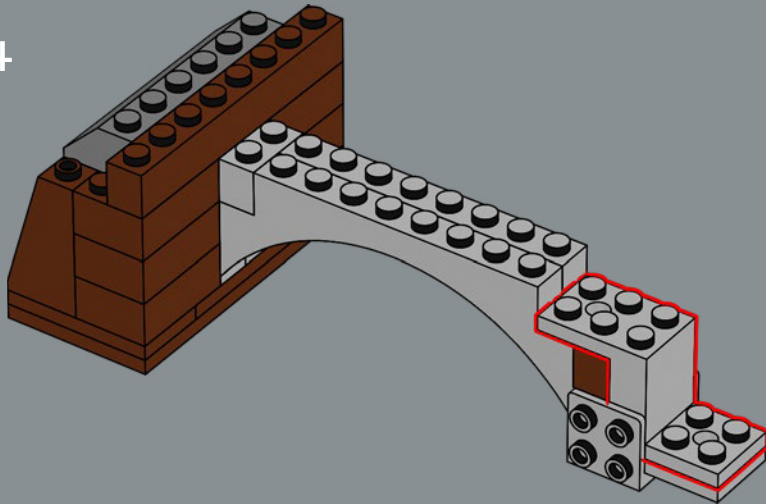

535

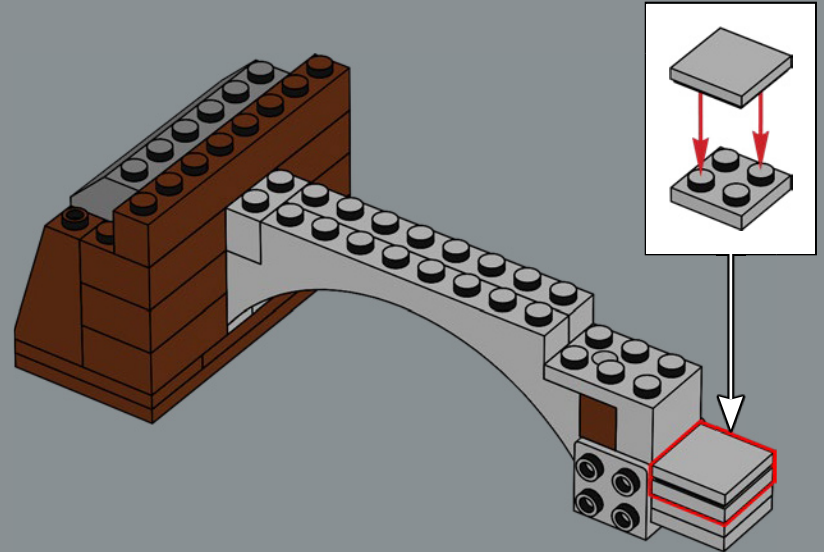

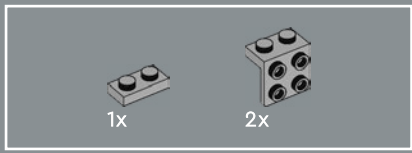

536

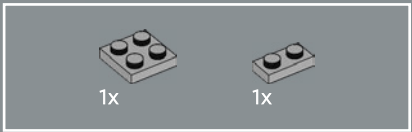
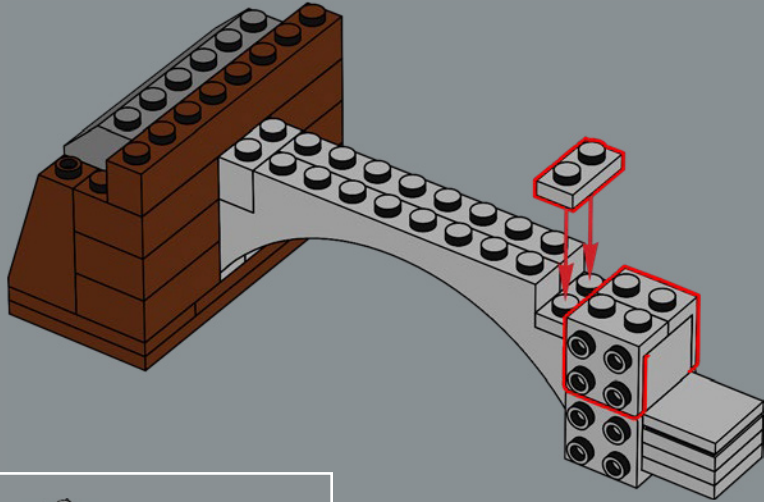

537

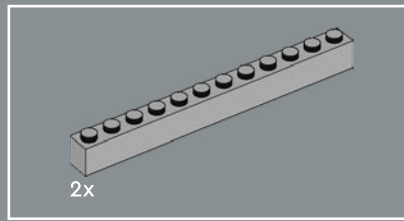
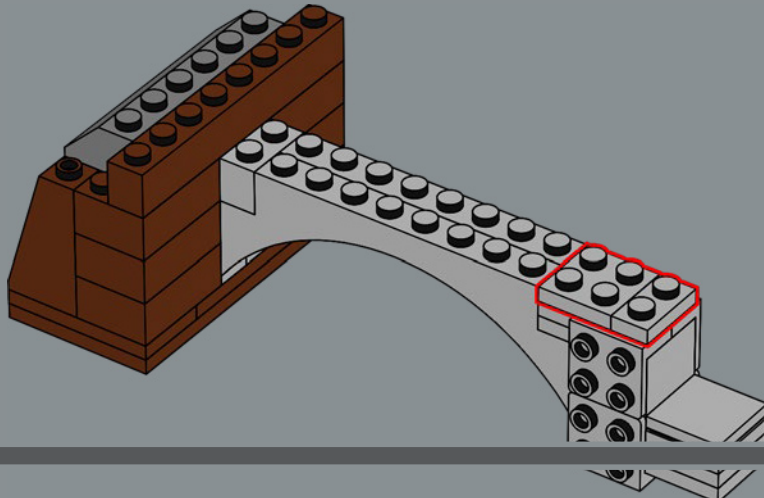

538

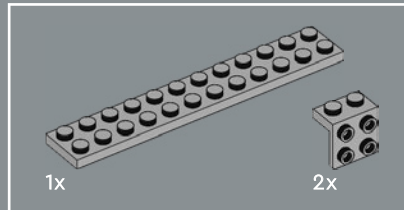
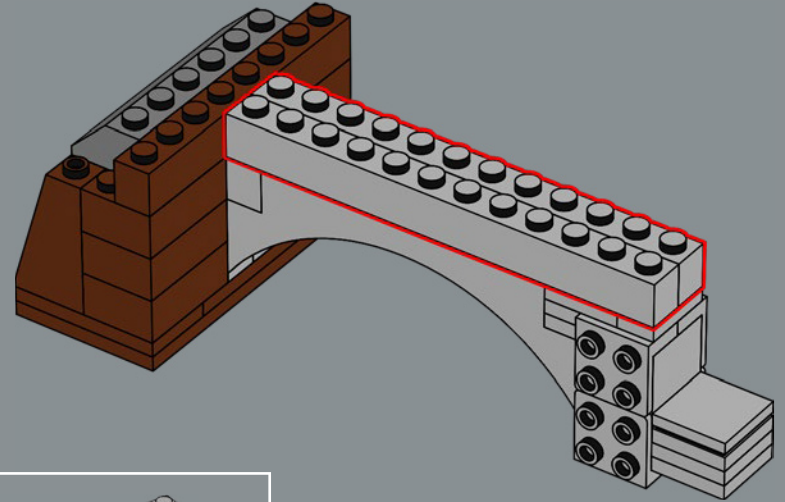

539

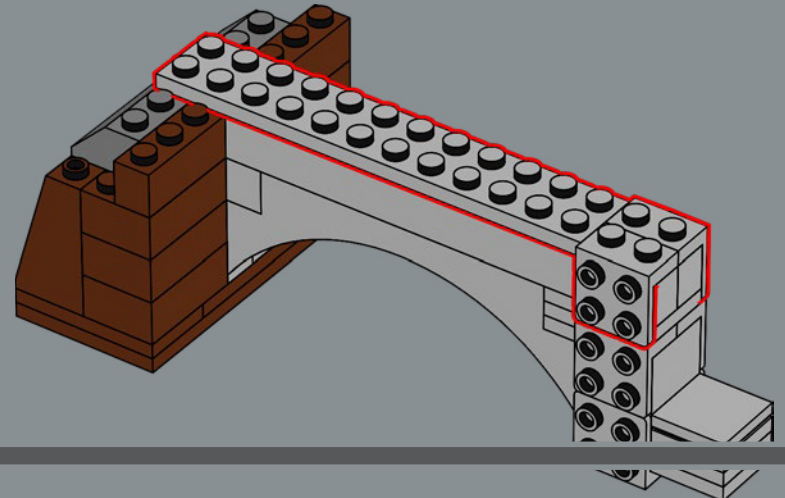

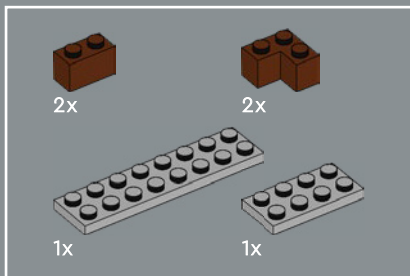

540

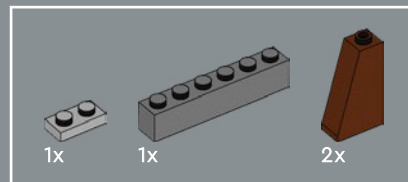
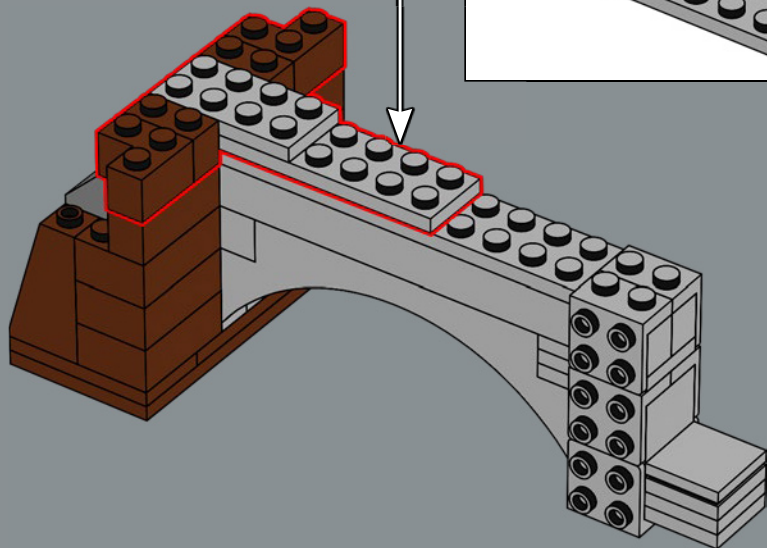
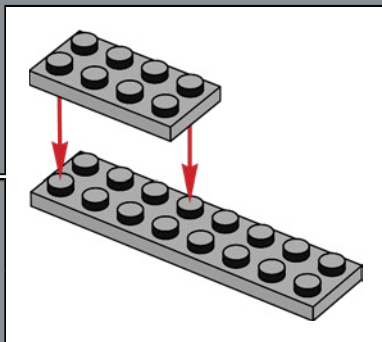

541

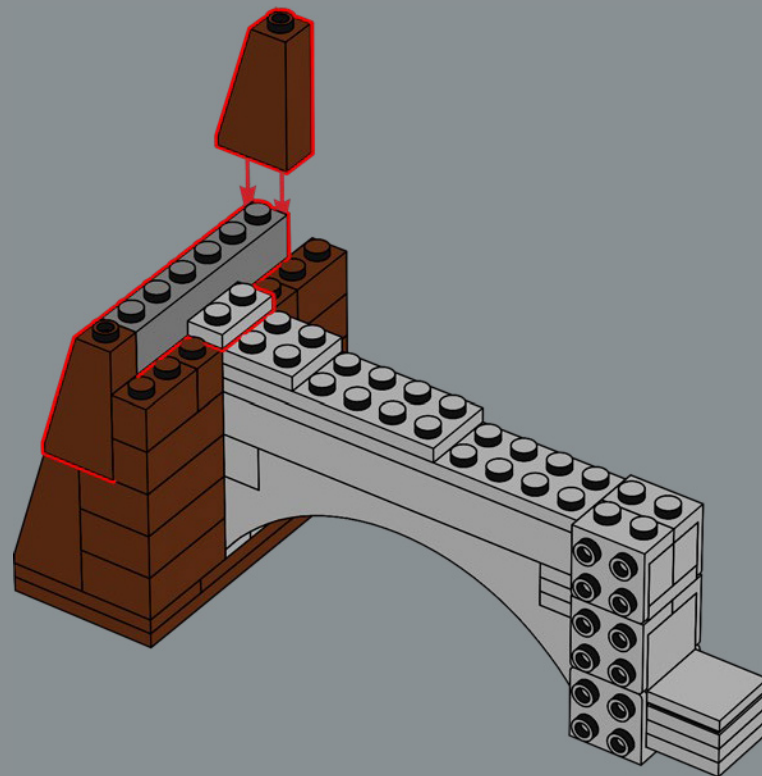

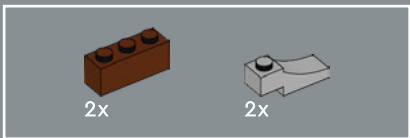

542

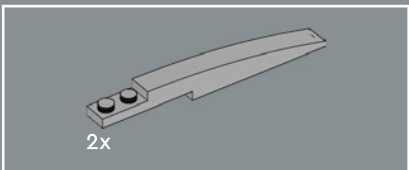
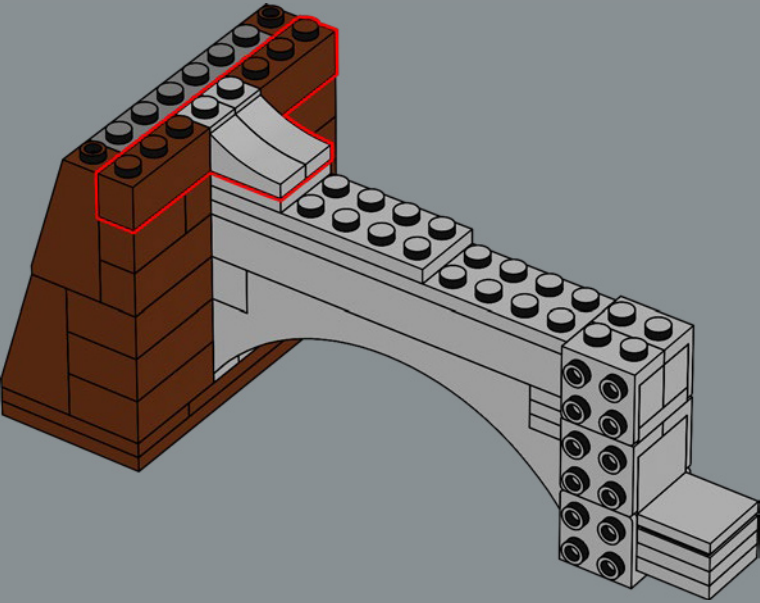

543

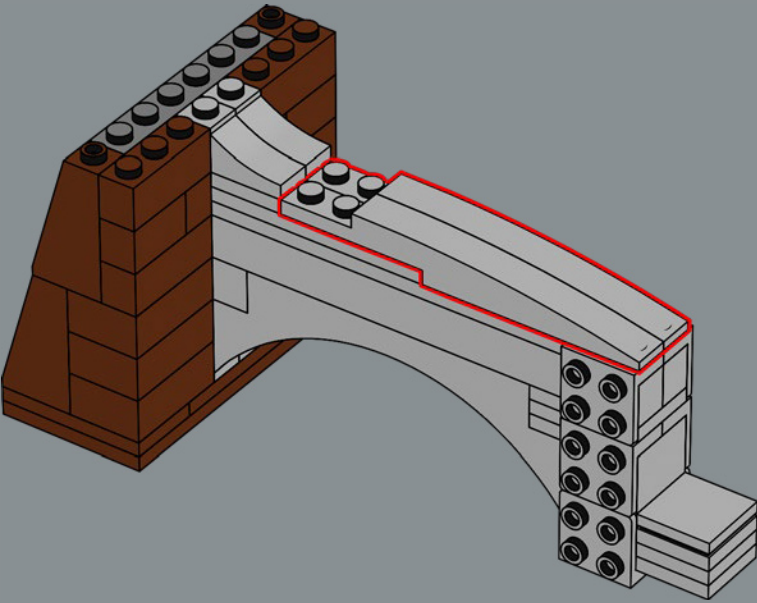

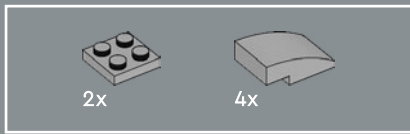

544

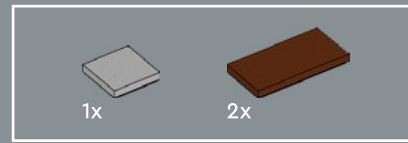
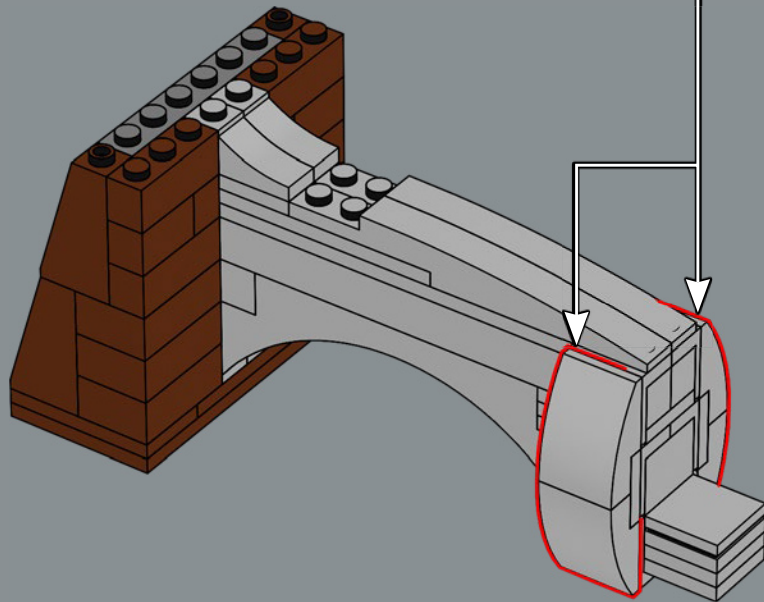
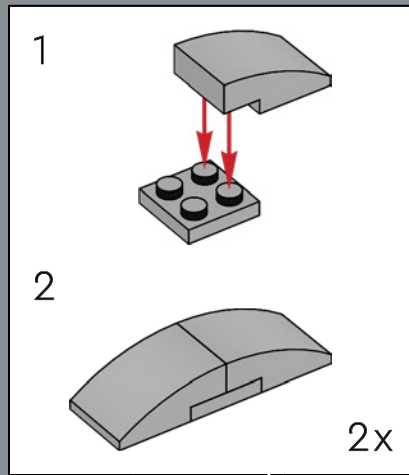

545

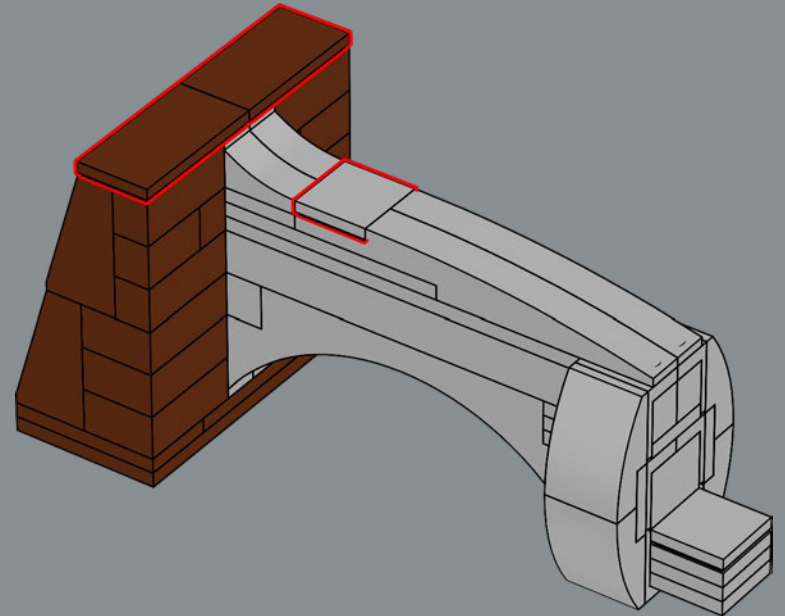

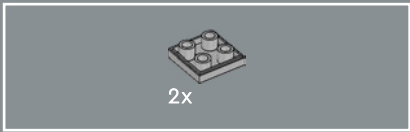

2x

546

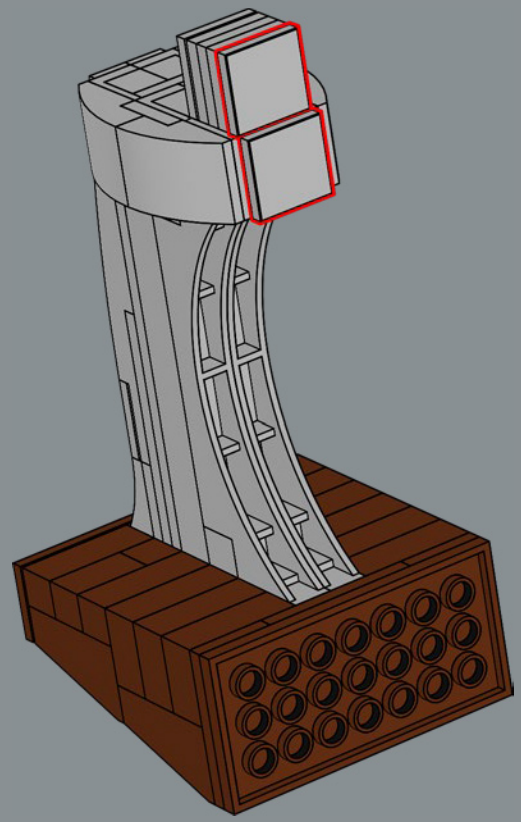

1x

547

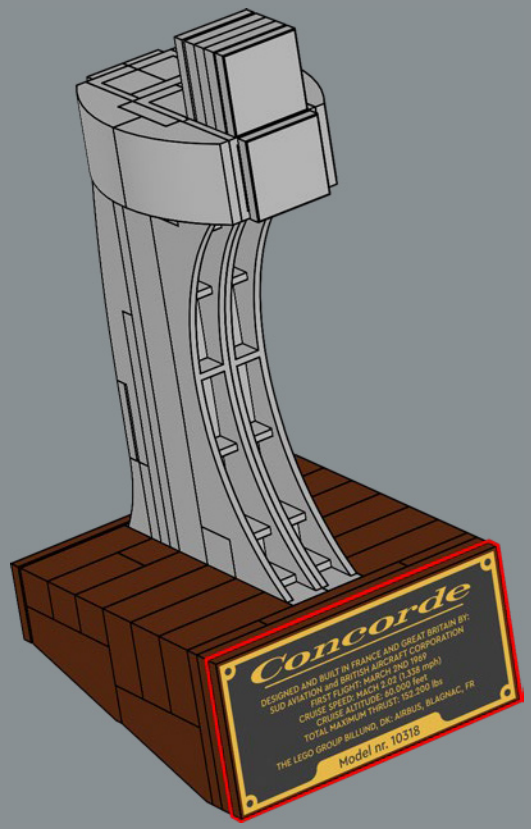

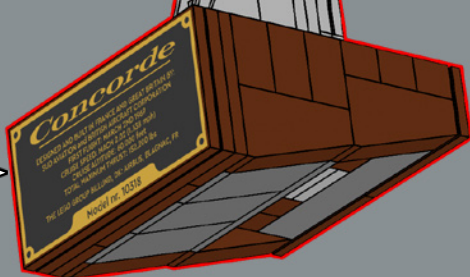
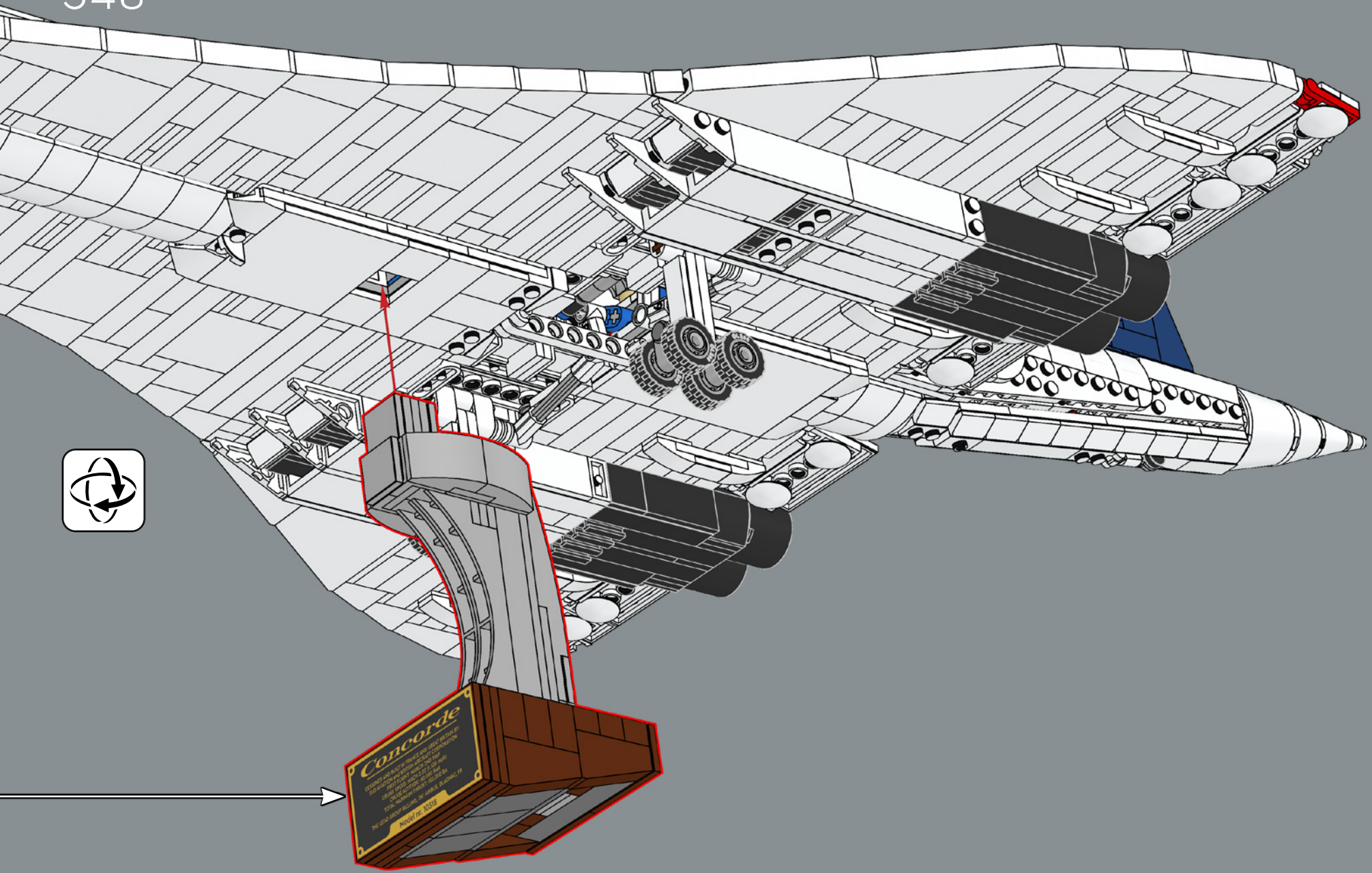



英国与法国的合作伙伴关系生产了航空史上最杰出的飞机之一，“Concorde”在英语和法语中的意思是“人与人之间的合作或和谐”。

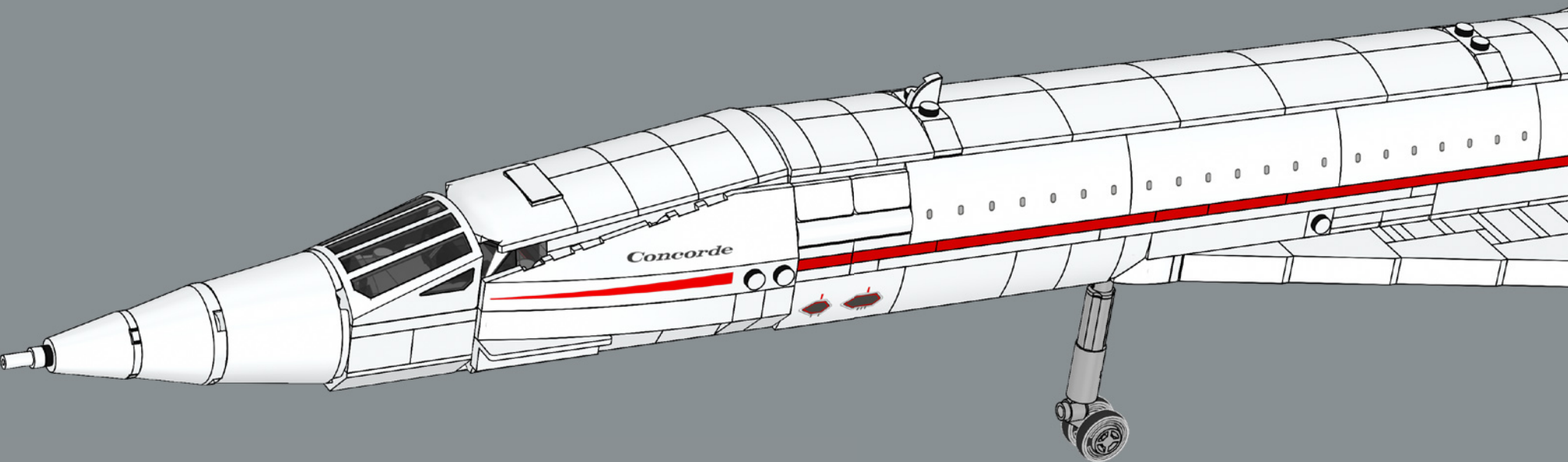

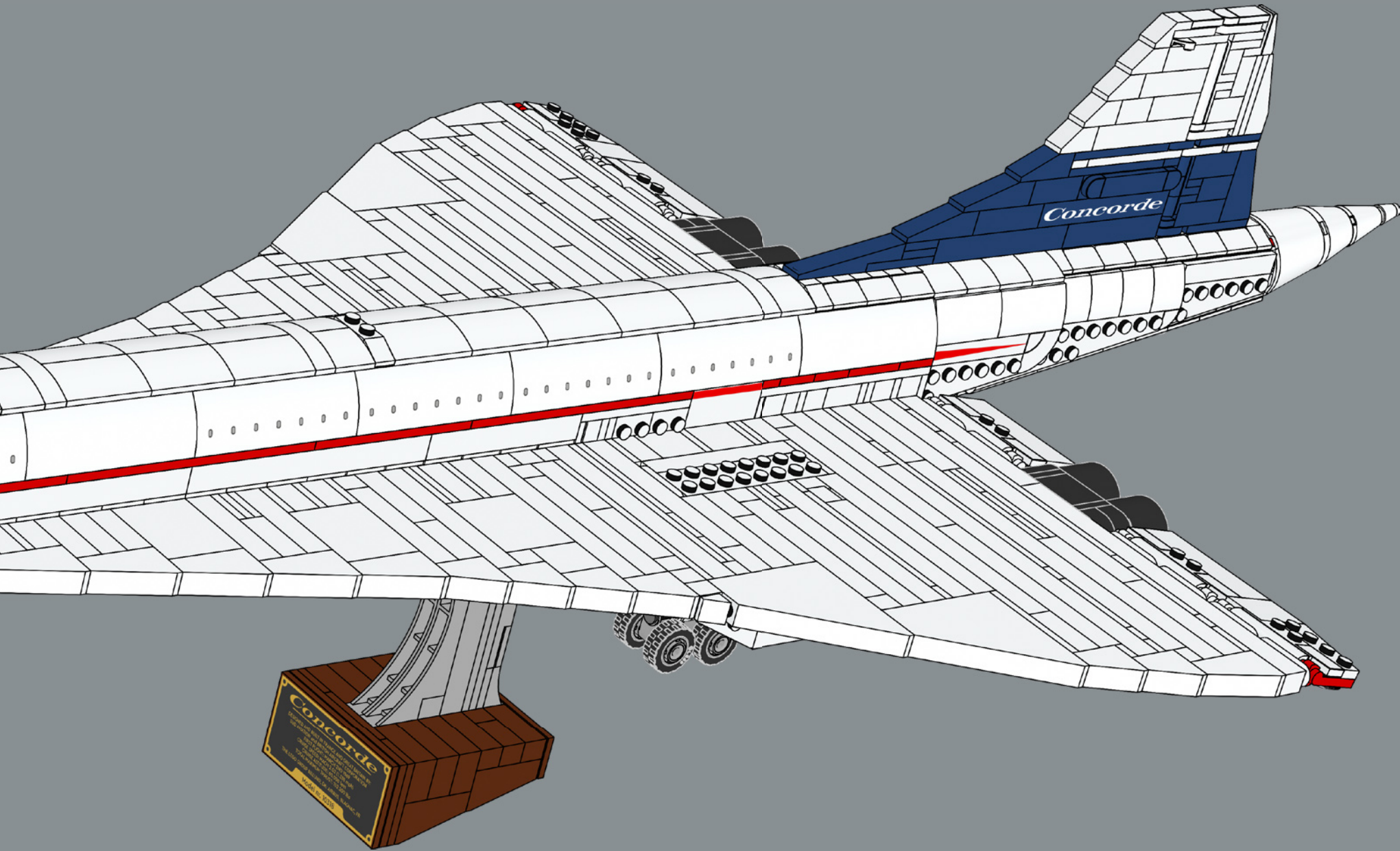

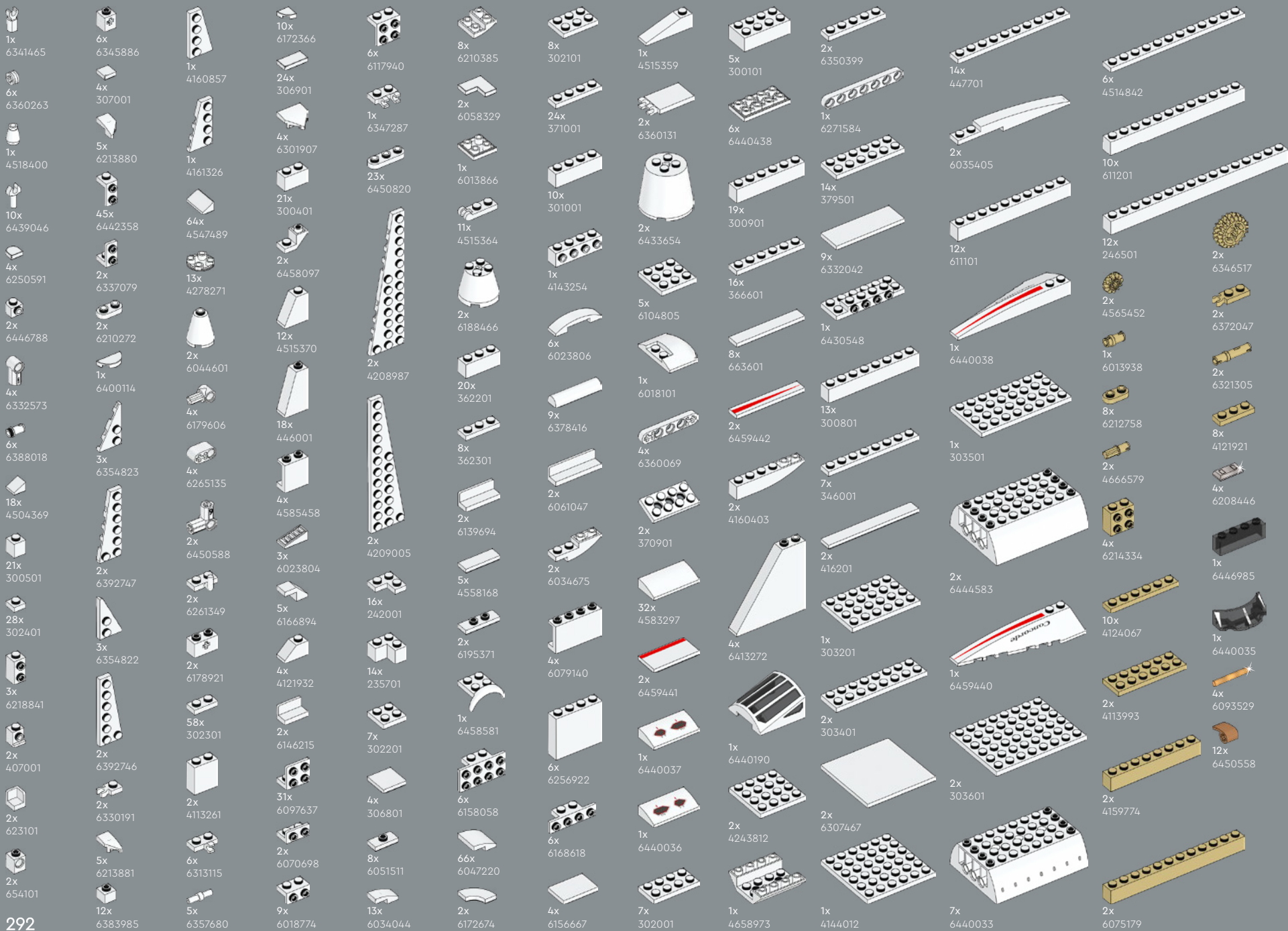

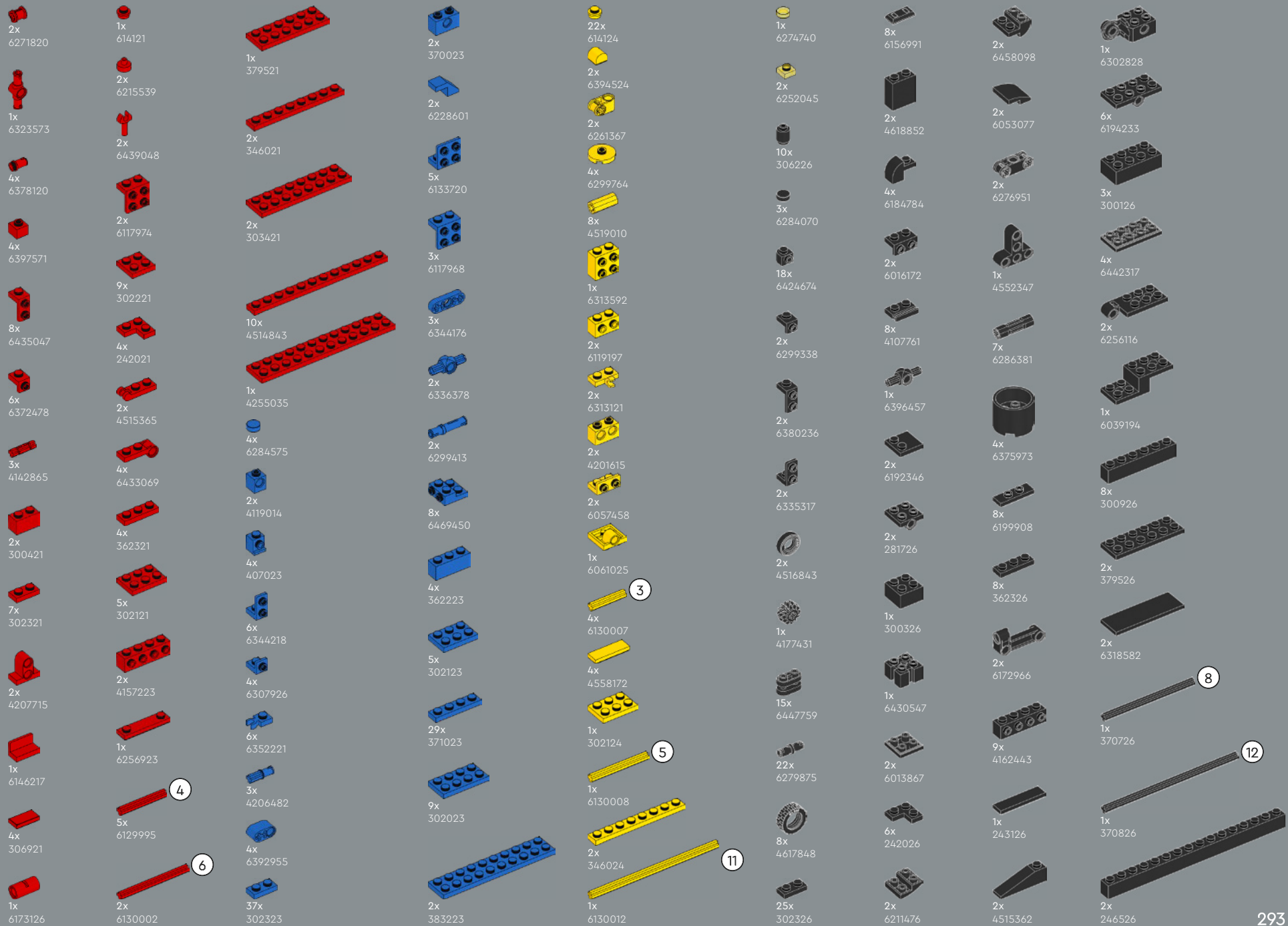



YOU COULD WIN



YOU COULD WIN

Your feedback will help shape the future development of this product series.

Visit:

DU KÖNNTEST GEWINNEN

Dein Feedback trägt zur Weiterentwicklung dieser Produktreihe bei.

Geh auf:

VOUS POURRIEZ GAGNER

Vos commentaires nous aideront à concevoir les futurs produits de cette gamme.

Visitez :

POTRESTI VINCERE TU

La tua opinione ci aiuterà a migliorare la creazione futura di questa linea di prodotti.

Visita:

PUEDES GANAR

Tu opinión contribuirá al futuro de esta serie de productos.

Visita:

轻松获奖

您的反馈将有助于我们在今后改进本产品系列。

请访问:

LEGO.com/productfeedback

You also have the chance to win a LEGO® set.

Terms and conditions apply.*

Außerdem hast du die Chance, ein LEGO® Set zu gewinnen.

Es gelten die Teilnahmebedingungen.*

Vous pourriez également gagner un ensemble LEGO®.

Des conditions s'appliquent.*

Hai anche la possibilità di vincere un set LEGO®.

Termini e condizioni sono applicabili.*

También tienes la oportunidad de ganar un set LEGO®.

Aplican términos y condiciones.*

您还有机会赢取乐高®套装。

条款和条件适用。*

*LEGO.com/productfeedback-terms



LEGO and the LEGO logo are trademarks of the LEGO Group. ©2023 The LEGO Group.
AIRBUS and Concorde are registered trademark of Airbus. It may not be used without Airbus' prior written consent. All rights reserved.